OWNER'S (OPERATOR'S) MANUAL AND SAFETY INSTRUCTIONS FOR TS SERIES (MODEL TS2) PLAIN AND GEARED TROLLEY

BEFORE USING THIS PRODUCT:

ALWAYS SAVE THIS BOOK FOR FUTURE REFERENCE

ALWAYS READ OWNER'S (OPERATOR'S) MANUAL AND SAFETY INSTRUCTIONS

▲ WARNING

: **IMPROPER trolley use could result in death or serious injury. To avoid these hazards:**

: **NEVER transport loads over or near people.**

: **NEVER work under or near lifted loads.**

: **ALWAYS operate, inspect, and maintain this trolley in accordance with applicable safety codes and regulations.**

: **ALWAYS follow the installation procedure on this manual when using the hoist with this TS2 trolley.**

These safety instructions contain important information to help you use the TS2 Trolley in a safe manner. Please refer to this Owner's (Operator's) Manual for additional safety information.

KITO®

CONTENTS

DEFINITIONS	1
1. SAFETY	1
1-1 Safety Summary	1
1-2 Safety instructions.....	2
2. TROLLEY SPECIFICATIONS	4
2-1 For manual chain hoist.....	4
2-2 For electric chain hoist	5
3. TROLLEY INSTALLATION	6
3-1 Coupling with manual chain hoists	6
3-2 Coupling with electric chain hoists.....	7
3-3 Adjusting trolley width before installation.....	8
3-4 Installation of trolley onto beam.....	9
3-5 Installation of stopper onto traversing beam.....	11
3-6 Installation of power supply cable	11
3-7 Check points after installation	12
4. OPERATION.....	12
4-1 Safety considerations.....	12
4-2 Operation	12
4-3 Trolley storage	12
4-4 Precaution in handling.....	13
5. INSPECTION	13
5-1 Outline	13
5-2 Daily inspection.....	13
5-3 Periodic inspection.....	14
5-4 Inspection method and judgment criteria.....	14
6. MAINTENANCE	17
6-1 Conditioning.....	17
6-2 Lubrication	17
6-3 Overhaul and assembly	18
7. BUFFER AND T-TYPE HANGER	20
7-1 Buffer	20
7-2 T-type hanger	20
8 WARRANTY	23
9 PARTS LIST	24

DEFINITIONS

⚠ WARNING : Death or serious injury could result in potentially hazardous situation.

1. SAFETY

1-1 Safety Summary

Danger exists when heavy loads are transported, particularly if the equipment is not being used properly or is poorly maintained. Because accidents and serious injury could result, special safety precautions apply to the operation, maintenance and inspection of trolleys.

Following these simple rules can help to avoid transporting accidents;

⚠ WARNING : Death or serious injury could result in improper trolley use.

To avoid these hazards:

- NEVER** use a trolley for transporting people. -----
- NEVER** lift or transport loads over or near people. -----
- NEVER** work near or under suspended loads. -----
- NEVER** transport more than the trolley's rated capacity. -----
- ALWAYS** notify others when transport is about to begin. -----
- ALWAYS** make sure that the supporting structures are strong enough to support the weight of the load and hoist. -----
- ALWAYS** read owner's (operator's) manual and safety instructions before operating. -----

REMEMBER: proper rigging and lifting techniques are the responsibility of the operator. Be sure you read and understand the instructions contained in this manual before using your trolley. Check all applicable safety codes, regulations and other applicable laws for further information about the safe use of your trolley.

More detailed safety information is contained in the following pages. For additional information, please contact Kito Corporation or your authorized Kito dealer.

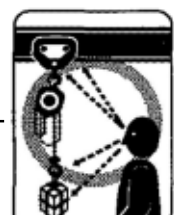
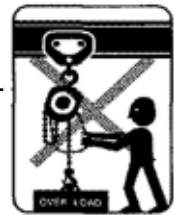
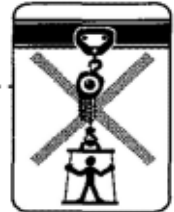

1-2 Safety instructions

Serious injury could result if the following safety instructions are not followed:

(If this trolley is used in conjunction with a hoist, also refer to the hoist manual for additional precautions and instructions.)

⚠ WARNING : Death or serious injury could result in improper trolley use. To avoid these hazards:

- NEVER** allow an unqualified (trained in safety and operation) person to operate the trolley.
- NEVER** apply loads which exceed the rated capacity of the trolley.
- NEVER** attach the hoist that has a rated capacity which exceeds the rated capacity of the trolley.
- NEVER** operate the trolley when a "DO NOT OPERATE" sign is placed on the trolley.
- NEVER** use a trolley if the width does not fit the rail.
- NEVER** use the hand chain to support a load.
- NEVER** transport a load over people.
- NEVER** use the trolley for transporting people.
- NEVER** allow anyone to stand on a suspended load.
- NEVER** swing a suspended load.
- NEVER** leave a suspended load unattended.
- NEVER** weld or cut a load suspended by the trolley.
- NEVER** connect the hoist to the trolley with improper fittings.
- NEVER** operate the trolley hand chain if excessive noise, jamming, overloading or binding occurs.
- NEVER** work near or under suspended loads.
- NEVER** operate a trolley if damaged or malfunctioning.
- NEVER** use a trolley which has been taken out of service until the trolley has been properly repaired or replaced.
- NEVER** use a trolley without a nameplate or warning labels or with illegible nameplate or labels.
- NEVER** remove or obscure the warning tags.
- NEVER** operate a trolley unless you are physically capable of doing so.
- NEVER** allow a trolley to collide with another trolley or stopper on the beam.
- NEVER** operate trolley unless load is centered under trolley.

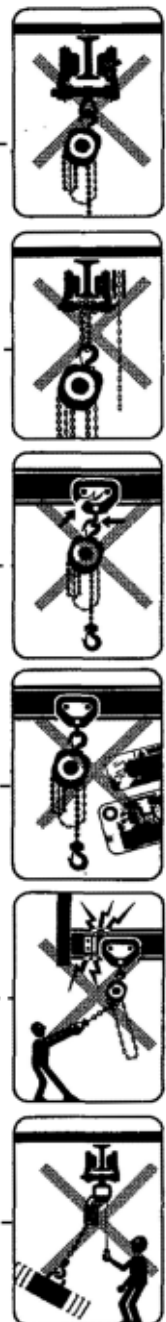

⚠ WARNING : IMPROPER trolley use could result in death or serious injury. To avoid these hazards:

- ALWAYS** make sure that you and others are clear of the load path.
- ALWAYS** inspect the trolley for wear or damage before each shift.
- ALWAYS** inspect the trolley thoroughly and replace worn or damaged parts.
- ALWAYS** lubricate the trolley regularly.
- ALWAYS** pay attention to the load at all times when operating the trolley.
- ALWAYS** rig the load properly and carefully.
- ALWAYS** check the trolley before daily use according to the Recommended Daily Inspection.
- ALWAYS** let the authorized personnel inspect the trolley periodically.
- ALWAYS** consult the manufacturer or your dealer if you plan to use a trolley in an excessively corrosive environment.
- ALWAYS** use the trolley within rail slope of 1/50.

2. TROLLEY SPECIFICATIONS

2-1 For manual chain hoist

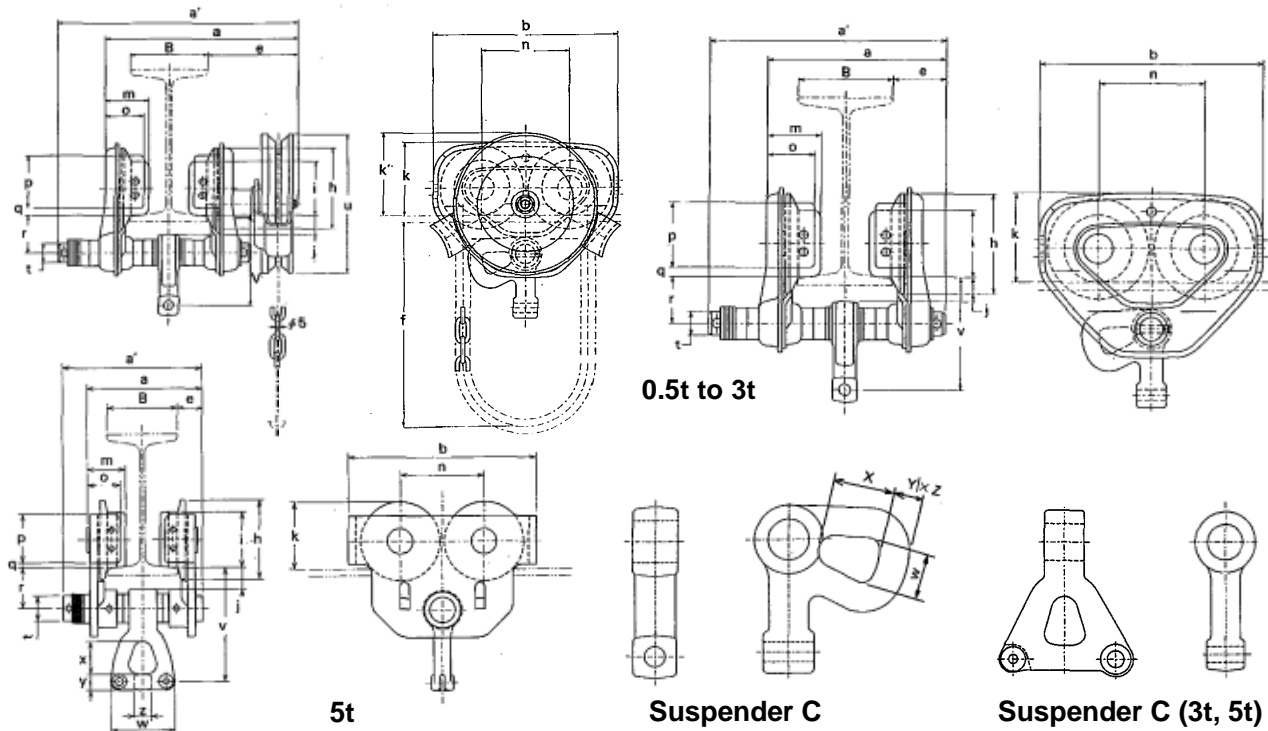

Table 1

Model	Code		Capacity (t)	Rail Width Adjustability			Min. Radius for Curve (mm)	Net Weight (kg)		Hand Chain Folded Length (m)	V (mm)	W (mm)	X (mm)	Y (mm)	Z (mm)	a [Max.] (mm)	a (mm)	b (mm)
	Plain Trolley	Geared Trolley		Standard	Option			TSP	TSG									
					W20	W30												
TS2	TSP005C	-	0.5	50 to 102	103 to 203	204 to 305	1100*	4.5	-	-	93	26	33	14	14	173	204	182
TS2	TSP010C	TSG010C	1	58 to 127	128 to 203	204 to 305	1300*	8	12	2.5	106	28	37	18	18	275 (215)	309 (249)	236
TS2	TSP015C	TSG015C	1.5	82 to 153	-	154 to 305	1500	14	18	2.5	129	32	40	22	22	349 (264)	385 (300)	280
TS2	TSP020C	TSG020C	2	82 to 153	-	154 to 305	1500	14	19	3	129	32	40	22	22	349 (264)	385 (300)	280
TS2	TSP025C	TSG025C	2.5	82 to 153	-	154 to 305	1700	23	27	3	144	36	44	27	25	359 (280)	398 (320)	324
TS2	TSP030C	TSG030C	3	82 to 153	-	154 to 305	1700	23	27	3	169	40	48	24	30	359 (280)	398 (320)	324
TS2	TSP050C	TSG050C	5	100 to 178	-	179 to 305	2300	50	56	3.5	228	60	70	33	36	376 (273)	400 (297)	400

Capacity (t)	e (mm)	f (mm)	h (mm)	i (mm)	j (mm)	k (mm)	k' (mm)	m (mm)	n (mm)	o (mm)	p (mm)	q (mm)	r (mm)	t (mm)	u (mm)
0.5	46	-	82	60	19	76	-	45	84	42	54	10	38	22	-
1	116 (56)	2.2	106	71	28	95	106	56	112	50	69	10	50	25	183
1.5	154 (69)	2.2	127	85	34	112	109	71	131	63	83	10	62	32	183
2	154 (69)	2.7	127	85	34	112	109	71	131	63	83	10	62	32	183
2.5	157 (79)	2.7	148	100	36	134	114	80	152	74	102	10	68	36	183
3	157 (79)	2.7	148	100	36	134	114	80	152	74	102	10	68	36	183
5	156 (53)	3.2	169	118	47	144	131	81	178	70	104	10	88	54	183

• Figures in parentheses show the data for plain trolley type.

• The maximum 200mm and 300mm rail width are available as option.

* Minimum flange width for curved rail : 0.5 ton trolley57mm.
 : 1 ton trolley.....73mm.
 : 2.5 and 3 ton trolley.....89mm.

• Net weight is when flange width is in standard range.

• Dimension "a" is when flange width is in standard range.

• Dimension "a" is when flange width is adjusted to the maximum of the standard range.

2-2 For electric chain hoist

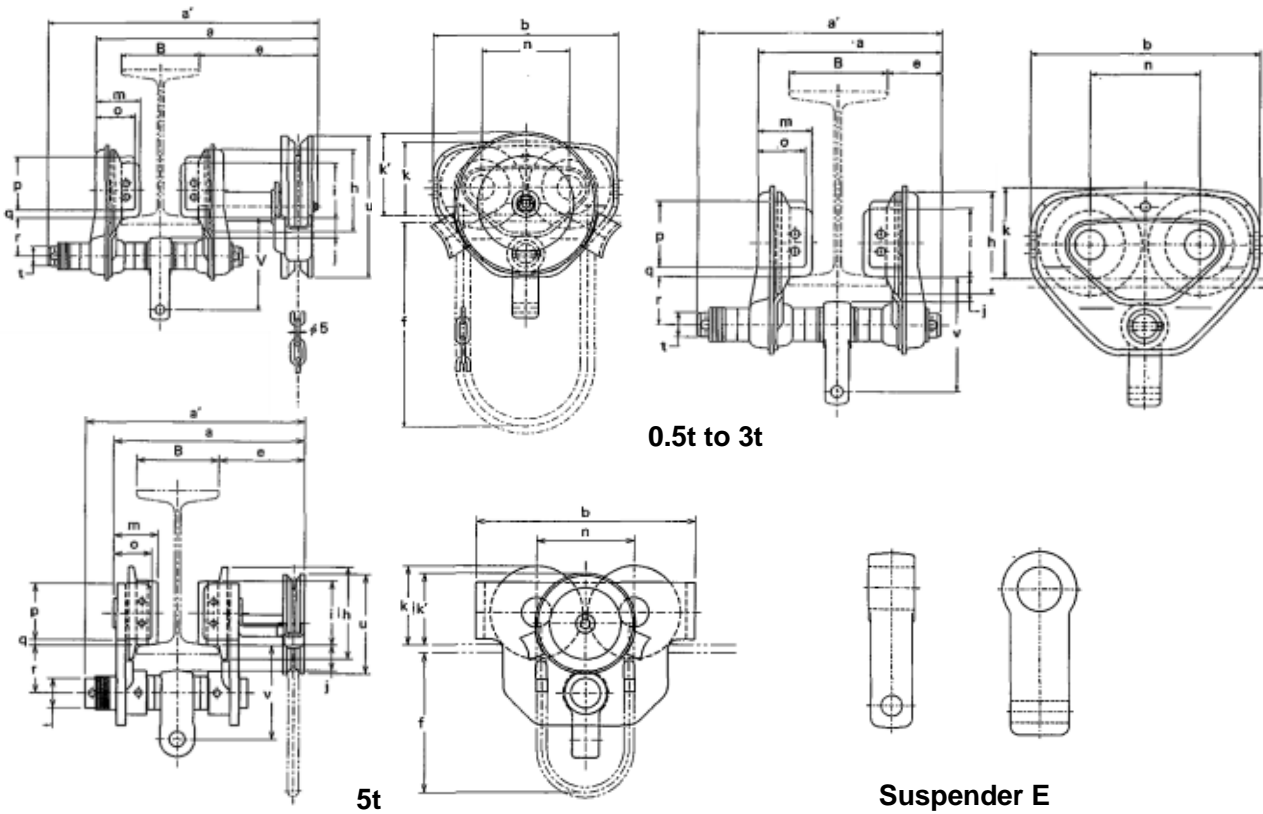

Table 2

Model	Code		Capacity (t)	Rail Width Adjustability			Min. Radius for Curve (mm)	Net Weight (kg)		Hand Chain Folded Length (m)	V (mm)	a [Max.] (mm)	a' (mm)	b (mm)
	Plain Trolley	Geared Trolley		Standard	Option			TSP	TSG					
					W20	W30								
TS2	TSP005E	-	0.5	50 to 102	103 to 203	204 to 305	1100*	4.5	-	-	98	173	204	182
TS2	TSP010E	TSG010E	1	58 to 127	128 to 203	204 to 305	1300*	8.0	12	3.0	119	311 (215)	345 (249)	236
TS2	TSP020E	TSG020E	2	82 to 127	-	204 to 305	1500	14	19	3.0	138	349 (264)	385 (300)	280
TS2	TSP025E	TSG025E	2.5	82 to 153	-	154 to 305	1700	23	27	3.0	153	359 (280)	398 (320)	324
TS2	TSP030E	TSG030E	3	82 to 153	-	154 to 305	1700	23	27	3.0	153	359 (280)	398 (320)	324
TS2	TSP050E	TSG050E	5	100 to 178	-	179 to 305	2300	50	56	3.5	171	376 (273)	400 (297)	400

Capacity (t)	e (mm)	f (mm)	h (mm)	i (mm)	j (mm)	k (mm)	k' (mm)	m (mm)	n (mm)	o (mm)	p (mm)	q (mm)	r (mm)	t (mm)	u (mm)
0.5	46	-	82	60	19	76	-	45	84	42	54	10	38	22	-
1	152 (56)	2.7	106	71	28	95	106	56	112	50	69	10	50	25	183
2	154 (69)	2.7	127	85	34	112	109	71	131	63	83	10	62	32	183
2.5	157 (79)	2.7	148	100	36	134	114	80	152	74	102	10	68	36	183
3	157 (79)	2.7	148	100	36	134	114	80	152	74	102	10	68	36	183
5	156 (53)	3.2	169	118	46.5	144	131	81	178	70	104	10	88	54	183

- Figures in parentheses show the data for plain trolley type.
- Minimum flange width for curved rail : 0.5 ton trolley57mm.
: 1 ton trolley.....73mm.
: 2.5 and 3 ton trolley.....89mm.
- The maximum 200mm and 300mm rail width are available as option.

- Net weight is when flange width is in standard range.
- Dimension "a" is when flange width is in standard range.
- Dimension "a" is when flange width is adjusted to the maximum of the standard range.

3. TROLLEY INSTALLATION

3-1 Coupling with manual chain hoists

- (1) The M3 series hoists can be suspended either in the hook suspension method (the top hook is hung from the suspender C as shown in Fig. A), or in the direct-coupling method (the hoist body, with the top hook removed, is directly coupled to the suspender C as shown in Fig. B). However, the 7.5 ton and larger capacity CB series hoist can only be suspended by the hook suspension method and the top hook must be hung directly from the suspension shaft of the trolley.

The CQ series hoist can be suspended by suspender C like Fig. A and C.

For color adjustment, refer to page 10.

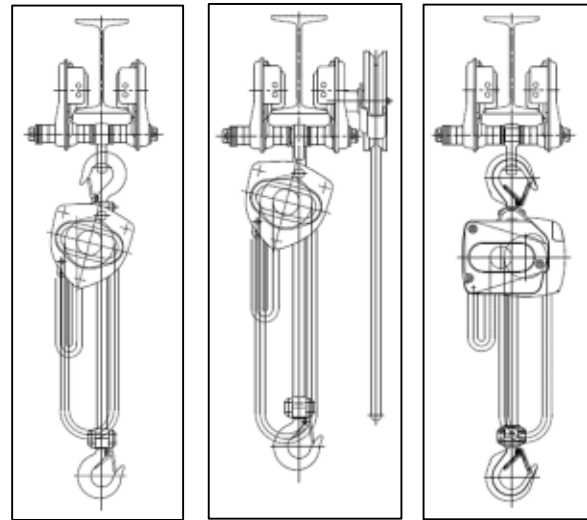

Fig. A

Fig. B

Fig. C

- (2) The direct-coupling method is best for circumstances which require as much effective hoisting length as possible, but where the height of the ceiling is low.

The hook suspension method is best for circumstances when the chain hoist is transferred frequently.

- (3) Direct Coupling method of M3 series top hook chain hoist.

- 1) For 0.5 to 2.5 ton capacity (Refer to Fig. 1)

- a) Remove the wheel cover nuts and spring washer, then remove the wheel cover itself.
- b) Straighten and remove the bent split pin in the top pin, pull out the top pin and remove the top hook.
- c) Mount the suspender to the hoist body using the top pin and the split pin which have been removed as above.
- d) Firmly bend the pointed end of the split pin as shown in Fig. 2.
- e) Install the wheel cover, as it was before, with the nuts and spring washers.

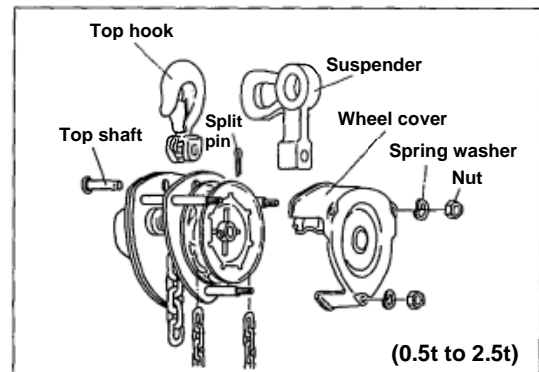

Fig. 1

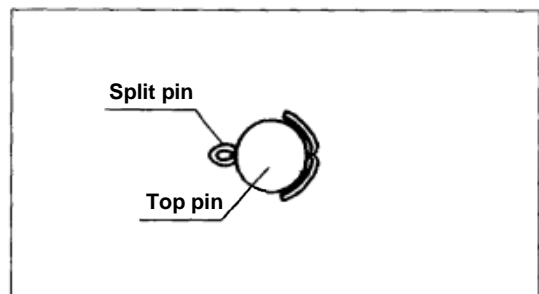

Fig. 2

2) For 3 or 5 ton capacity. (Refer to Fig. 3.)

In addition to the procedure stated above, the following steps are also required.

- a) Straighten the bent split pin, remove the slotted nuts, pull out the chain pins, and then remove the load chain from the top hook, in Fig. 3.
- b) Connect the end of load chain and the suspender with chain pins, slotted nuts and the split pin.
- c) Firmly bend the pointed end of the split pin.
- d) Make sure that no twisting and no capsizing of load chain occurs.

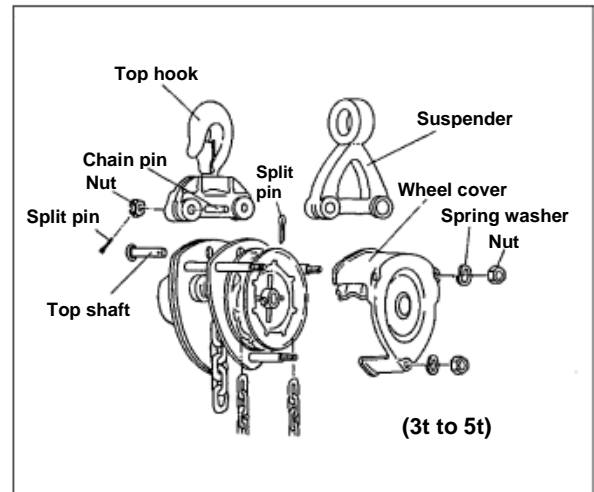

Fig. 3

3-2 Coupling with electric chain hoists

• ER series

The direct coupling method is shown in Fig. D.

Installation of suspender (Refer to Fig. 4)

Mount the suspender G to the connection yoke with the connection yoke rubber, the yoke bolt and the slotted nut. Then insert a new split pin and bend it securely as shown in Fig. 2.

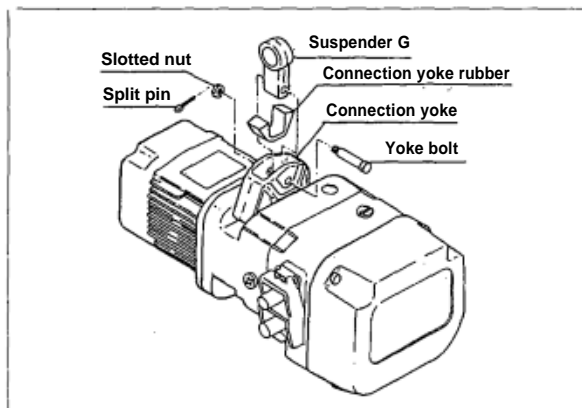

Fig. 4

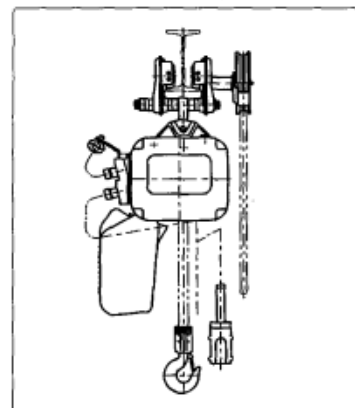

Fig. D

- **ED series**

The direct coupling method is shown in Fig. E.

- (1) For ED (up to 240kg)

Hook the top hook onto the suspender before use. For color adjustment, refer to page 10.

- (2) For ED (480kg only)

Remove the split pin and slotted nut from the yoke bolt, and detach the top hook. Then, install the Suspender onto the hoist body using the yoke bolt, and secure it with the slotted nut and split pin.

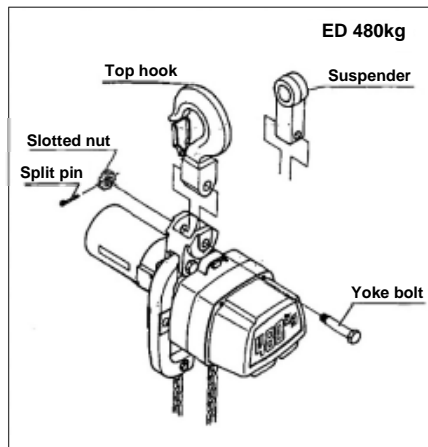

Fig. 5

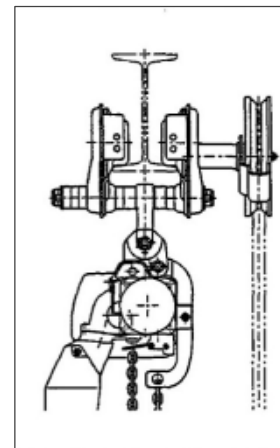

Fig. E

For detailed installation information for the following models, refer to each corresponding instruction manual:

- ER2
- EQ
- AIR HOIST

3-3 Adjusting trolley width before installation

When the trolley and the chain hoist are combined, the following procedures must be followed to adjust the trolley width by using the inner and outer adjusting spacers (Refer to Table 3 on page 9).

- (1) Make sure that the direction is as shown in Fig. A to E.
- (2) The right and left side plates should be as far apart as possible, and the difference between A and B should be approximately 4 mm (Refer to Fig. 6).
- (3) Bend the split pin of the shaft stopper pin as shown in Fig. 7.

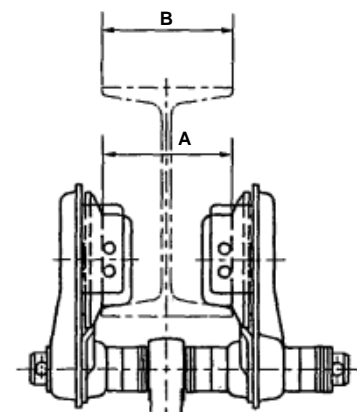

Fig. 6

3-4 Installation of trolley onto beam

- (a) It is preferable to install the trolley from the end of the beam, with the chain hoist and the trolley coupled. After installation, make sure to re-install the stopper as it was.
- (b) When there is no space between the end of beam and building, first remove the side plate S from the suspension shaft. After placing the side plate G on the other side of the flange, reassemble and re-install side plate S as it was before. Also, bend the split pin of the shaft stopper pin correctly as shown in Fig. 7.

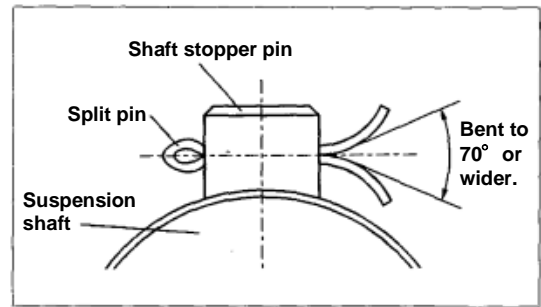

Fig. 7

3-5 Installation of stopper onto traversing beam

Make sure to install the stopper at both ends of the beam. Also, refer to Table 4, Fig. 8 and Fig. 9 below when installing the stopper.

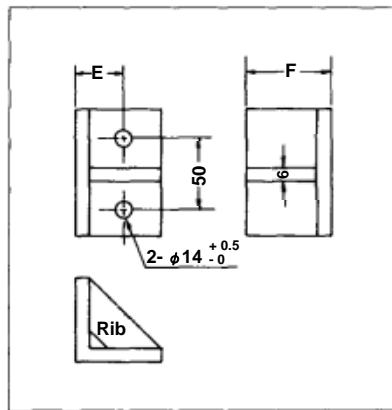

Fig. 8

Stopper size

* Only for reference

Beam Width B (mm)	Stopper Material (mm)	E (mm)	F (mm)	Quantity	Bolt	Nut
75	L-50x50x6	30	30	4	M12x55x55 (For bolts)	M12 (Eight nuts)
100	L-50x50x6	30	40	4		
125	L-50x50x6	30	50	4		
150	L-65x65x8	35	65	4		
175	L-75x75x9	40	75	4		

Table 4

Stopper installation

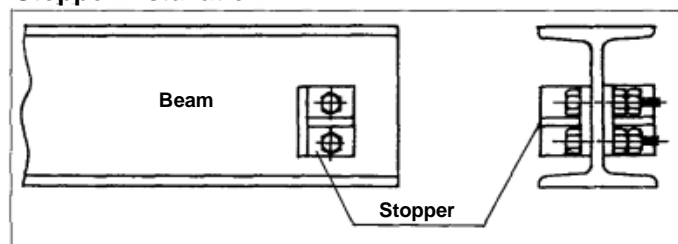

Fig. 9

3-6 Installation of power supply cable

Install it as the following procedure.

- (1) Provide messenger wire (3 to 6mm dia. steel cable) along the beam, and make the power supply cable run with the cable hangers through the messenger wire so that it would not be twisted.
- (2) In case hoist is connected with plain trolley or geared trolley, provide messenger wire slightly outside the cable receiver of the hoist (See Fig. 10).

* When the curved beam is used, the messenger wire cannot be attached to the beam. For this case, a special T type cable hanger for the curved beam is available as option (See page 21, Fig. 22).

* Consult your authorized Kito dealer in case the electrical power supply is by means of any other method.

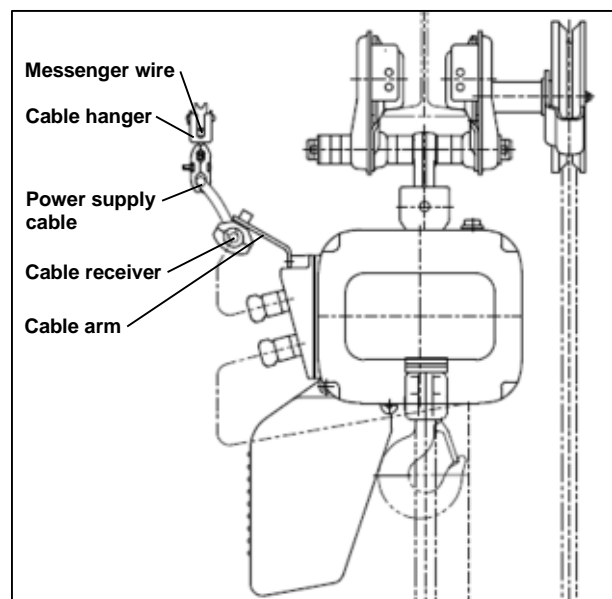

Fig. 10

3-7 Check points after installation

When the entire installation is completed, check the followings.

- (1) Check whether the relative position of the trolley and the chain hoist is correct (See Fig. A to E).
- (2) Check that the beam stoppers are securely fastened on the rail to prevent trolley run away.
- (3) Make sure that no bolt, nut, split pin or snap pin are missing, and that those are all adequately fastened.

4. OPERATION

4-1 Safety considerations

The three most important aspects of trolley operation are:

- (1) Follow all safety instructions when operating trolley,
- (2) Allow only qualified people to operate a trolley and
- (3) Subject each trolley to a regular inspection and a maintenance procedure.

4-2 Operation

(1) Plain trolley

For plain trolley, movement is controlled by pushing on the load or the hook of the attached hoist.

(2) Geared trolley

For geared trolley, when facing the trolley hand wheel:

Pull down on right side of hand chain (Clockwise rotation) to move left.

Pull down on left side of hand chain (Counterclockwise rotation) to move right.

4-3 Trolley storage

NEVER expose the trolley to rain or dew.

NEVER leave the trolley in a damp place.

ALWAYS be sure to house the trolley under the eaves or under some cover after use, in the case of outdoor installation.

ALWAYS wipe off all dirt and water.

ALWAYS install in a dry place.

ALWAYS lubricate gear side of the pinion and track wheel G.

4-4 Precaution in handling

(1) Avoid slant loading

It is dangerous to pull the load slant, with the trolley connected to the hoist, as the trolley is inclined and gives too much strain to the trolley.

(2) Avoid collision

The trolley will be damaged if it is bumped against stopper or against another trolley.

(3) Never allow articles to become caught or hooked onto the hand chain.

When articles are hooked or caught on the hand chain and the hand chain is strongly pulled, severe damage will be caused not only to the hand chain but also to the trolley itself.

(4) Never overload

The nameplate on the trolley shows the maximum lifting capacity. If the capacity of the trolley is different from the capacity of the chain hoist with which it is combined, operates them within the capacity of whichever smaller.

(5) Never throw

Never throw or drag the trolley.

Always handle trolleys with care.

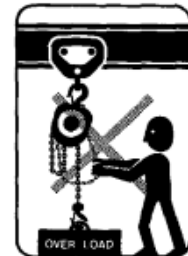

5. INSPECTION

5-1 Outline

There are two types of inspection, the daily inspection performed by the operator while using the trolley, and the more thorough periodic inspection performed by qualified personnel who have the authority to remove the unit from service.

5-2 Daily inspection

ALWAYS check the following points before each work shift.

- (1) Check for visual signs or abnormal noises which could indicate a potential malfunction.
- (2) Check hand chain movement around the hand wheel.
- (3) Clean the chain. if chain binds, jumps, "clicks" or is excessively noisy.
- (4) Replace the chain, if problem persists.
- (5) Check for smooth operation.

5-3 Periodic inspection

Periodic inspection should be made at the interval shown below and should follow the given procedures.

NORMAL (Normal use):	Semiannual inspection
HEAVY (Frequent use):	Quarterly inspection
SEVERE (Excessively frequent use):	Monthly inspection

Inspect all the items in "Periodic Inspection". Also inspect the following.

- (1) Check rivets, split pins, cap screws and nuts. Replace if missing and tighten if loose.
- (2) Inspect for wear, damage, distortion, deformation and cleanliness. If external evidence indicates the need, disassemble
- (3) Check gears, shafts, bearings and chain guides. Replace worn or damaged parts. Clean, lubricate and reassemble
- (4) Check for damage or excessive wear. Replace if necessary.
- (5) Check for distortion, wear and continued ability to support load.
- (6) Check that the trolley wheels track the beam properly and total clearance between wheels and flange equals to approximately 4mm. (Refer to 3-3 on page 8.) Adjust the clearance if necessary.
- (7) Check side plates for spreading due to bending. Repair as necessary.
- (8) Check name plates for presence and legibility. Replace if necessary.

5-4 Inspection method and judgment criteria

5-4-1 Daily inspection procedure

Inspection Item	Inspection Method	Discard Limits / Judgment Criteria	Countermeasures/ Others
1. Function	• Run under no load condition.	• Trolley should run smoothly and is not tilt when a light load is applied.	• If the movement is not smooth, try to determine its cause and replace the trolley with a new one if necessary.
2. Deformations and damages of each part	• Check visually.	• There should be no deformation or damage.	• Replace the part with a new one if deformed or damaged.
3. Part loosening	• Check visually.	• Parts should not be loosened.	• Fasten tightly.
4. Name plate	• Check visually.	• Every description should be clear and visible.	• Replace the name plate with a new one.

5-4-2 Periodic inspection procedure

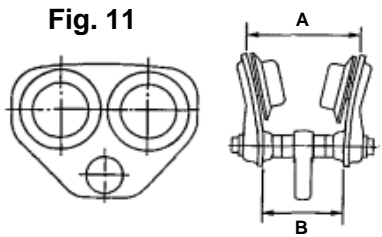
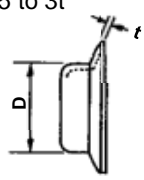
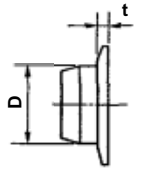
Inspection Item	Inspection Method	Discard Limits / Judgment Criteria	Countermeasures/ Others																																		
1. Traversing function	<ul style="list-style-type: none"> Move trolley with light load suspended. 	<ul style="list-style-type: none"> Trolley should run smoothly and not tilt when a light load is applied. Overall movement should be smooth. 	<ul style="list-style-type: none"> If not smooth, adjust beam, readjust balance or lubricate pinion holder, pinion and gear of track wheel G. 																																		
2. Side plate deformation	<ul style="list-style-type: none"> Check with calipers. 	<ul style="list-style-type: none"> Dimensions A and B should not exceed 2mm. <p>Fig. 11</p> 	<ul style="list-style-type: none"> If the difference exceeds 2mm, replace it with a new one. 																																		
3. Track wheel abrasion	<ul style="list-style-type: none"> Check visually or with calipers as needed. <p>Fig. 12 0.5 to 3t</p>  <p>Fig. 13 5t</p> 	<ul style="list-style-type: none"> Abrasion of tread or flange should not exceed the limits on the table below. <p>Table 5</p> <table border="1"> <thead> <tr> <th rowspan="2">Capacity (t)</th> <th colspan="2">Tread outside diameter : D</th> <th colspan="2">Flange thickness : t</th> </tr> <tr> <th>Standard</th> <th>Limit</th> <th>Standard</th> <th>Limit</th> </tr> </thead> <tbody> <tr> <td>0.5</td> <td>60</td> <td>58.5</td> <td>3.2</td> <td>2.5</td> </tr> <tr> <td>1</td> <td>71</td> <td>69.5</td> <td>4</td> <td>3.3</td> </tr> <tr> <td>2</td> <td>85</td> <td>83.5</td> <td>4.5</td> <td>3.8</td> </tr> <tr> <td>3</td> <td>100</td> <td>98.5</td> <td>5</td> <td>4.3</td> </tr> <tr> <td>5</td> <td>118</td> <td>112</td> <td>9.6</td> <td>6.7</td> </tr> </tbody> </table>	Capacity (t)	Tread outside diameter : D		Flange thickness : t		Standard	Limit	Standard	Limit	0.5	60	58.5	3.2	2.5	1	71	69.5	4	3.3	2	85	83.5	4.5	3.8	3	100	98.5	5	4.3	5	118	112	9.6	6.7	<ul style="list-style-type: none"> Replace it with a new one if it exceeds the limit.
Capacity (t)	Tread outside diameter : D			Flange thickness : t																																	
	Standard	Limit	Standard	Limit																																	
0.5	60	58.5	3.2	2.5																																	
1	71	69.5	4	3.3																																	
2	85	83.5	4.5	3.8																																	
3	100	98.5	5	4.3																																	
5	118	112	9.6	6.7																																	
4. Missing or damaged nameplate	<ul style="list-style-type: none"> Check visually. 	<ul style="list-style-type: none"> Never use the one which is not legible. 	<ul style="list-style-type: none"> Replace it with a new one. 																																		
5. Damage of hand wheel	<ul style="list-style-type: none"> Check visually. 	<ul style="list-style-type: none"> Never use the damaged one. 	<ul style="list-style-type: none"> Replace it with a new one. 																																		
6. Deformation and abrasion of gear (track wheel G, pinion)	<ul style="list-style-type: none"> Check visually or use calipers as needed. 	<ul style="list-style-type: none"> Never use the deformed or abraded one. 	<ul style="list-style-type: none"> Replace it with a new one. 																																		
7. Deformation and abrasion of suspension shaft	<ul style="list-style-type: none"> Check visually or use calipers as needed. 	<ul style="list-style-type: none"> Never use the suspension shaft if its diameter is worn by 10% or more. 	<ul style="list-style-type: none"> Replace it with a new one. 																																		

Inspection Item	Inspection Method	Discard Limits / Judgment Criteria	Countermeasures/ Others
8. Deformation and abrasion of suspender	• Check visually or use calipers as needed	• Never use the suspender if its dimensions of $D_2 - D_1$, d or h exceed the limits in Table 6 below.	• Replace if it exceeds the limit below.

Fig. 14

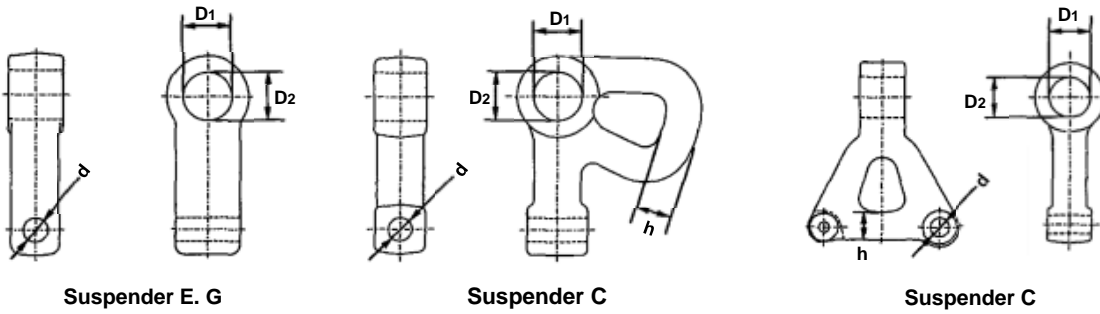

Table 6

(mm)

Susp. Type	Trolley capacity (t)	$D_2 - D_1$ limit	d		h	
			Standard	Limit	Standard	Limit
Susp.C	0.5	1	12.2	13	14	12.5
	1	1	12.2	13	18	16
	2	1	16.2	17	22	20
	3	1.5	16.2	17	27	24
		1.5	16.4	17	24	21.5
5	1.5	16.4	17	33	30	
Susp.E	0.5	1	12.2	13	—	—
	2	1	12.2	13	—	—
Susp.G	1	1	20.2	21	—	—
	3	1.5	20.2	21	—	—
	5	1.5	28.2	30	—	—

9. Rail deformation	• Check visually or use calipers as needed.	• The flange should not be deformed.	• Replace or repair.
10. Condition of welded part	• Check visually.	• There should be no crack. • There should be no rust.	• Repair or strengthen.
11. Rail abrasion	• Check visually or use calipers as needed.	• The tread should not be abraded. • Replace it if the dimension B becomes 95% t becomes 90% of a new one.	• Replace.
12. Loosening of fixing bolt	• Try to turn it with a spanner.	• The bolt should be tightened firmly.	• Tighten the bolt.

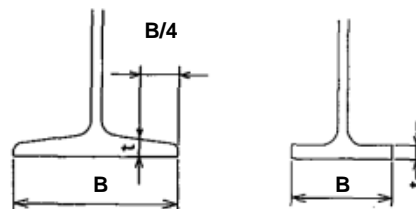

Fig. 15

6. MAINTENANCE

ALWAYS maintain, inspect and test the trolley in accordance with applicable safety codes and regulations.

Safety regulations for hoists and cranes regulate implementation and maintenance of daily inspection, monthly inspection, annual inspection and testing. All inspection and maintenance records should be kept for at least 3 years.

⚠ WARNING : IMPROPER trolley use could result in serious injury or death.

To avoid these hazards:

: NEVER perform maintenance on the trolley while it is suspending a load.

: Before performing maintenance, attach the tag:

["DANGER": DO NOT OPERATE EQUIPMENT BEING REPAIRED.]

: Only allow qualified service personnel to perform maintenance.

: After performing maintenance, test trolley to 100% of its rated capacity before returning to service.

6-1 Conditioning

6-1-1 Storing

- (1) In the event that the trolley or hoist becomes wet, dry the trolley or hoist with a dry cloth.
- (2) In the case of outdoor installation, make sure to house a trolley or hoist under the eaves or under some cover after operation.

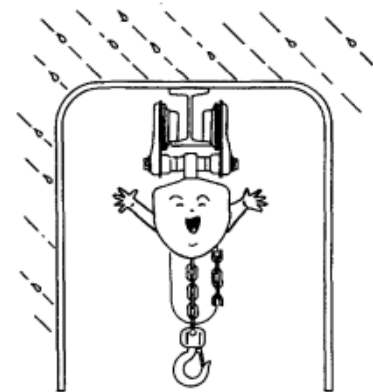

6-2 Lubrication

6-2-1 Geared wheels (geared trolley only)

Lubricate exposed trolley drive pinion and wheel teeth. Brush with grease as often as necessary to keep teeth liberally covered. If the grease becomes contaminated with sand, dirt or other abrasive materials, remove old grease and replace with new grease (standard grease*) during monthly or annual inspection.

Temperature range of standard grease is -40°C (-40°F) to +60°C (+140°F). If the hoist is used at temperatures below -40°C (-40°F) or above +60°C (+140°F), consult the manufacturer or dealer since some parts should be changed.

*Calcium soap grease equivalent of NLGI (National Lubricating Grease Institute) / 2, or EP 2.

6-2-2 Trolley wheels and hand chain

Trolley wheel bearings do not need to be lubricated and must be replaced if worn or damaged.

Hand chain, used on geared trolley, does not normally require lubrication.

6-3 Overhaul and assembly

Overhaul and assemble should be performed with reference to the following figures.

Fig. 23: for 0.5 t to 3 t plain trolley

Fig. 24: for 5 t plain trolley

Fig. 25: for 0.5 t to 3 t geared trolley

Fig. 26: for 5 t geared trolley

6-3-1 Precautions in overhaul and assembly

- (1) Part names are described in the parts list on pages 23 to 28.
- (2) For overhauling a geared trolley, remove the track wheel first, then take off the pinion.
- (3) Arrange the adjusting spacers as shown in Table 3.
- (4) When connecting a geared trolley, install it so that the trolley's hand chain should be on right side from the hoist's nameplate side.
- (5) Bend the split pin firmly as shown in Fig. 16-1 or 16-2. When removing the frame for installing the trolley onto the rail, tighten the split pin firmly after the installation is completed.
- (6) Place the shaft stopper pin as shown in Fig. 16-1 or 16-2 and the flat surface should touch the adjusting spacers.

Fig. 16-1

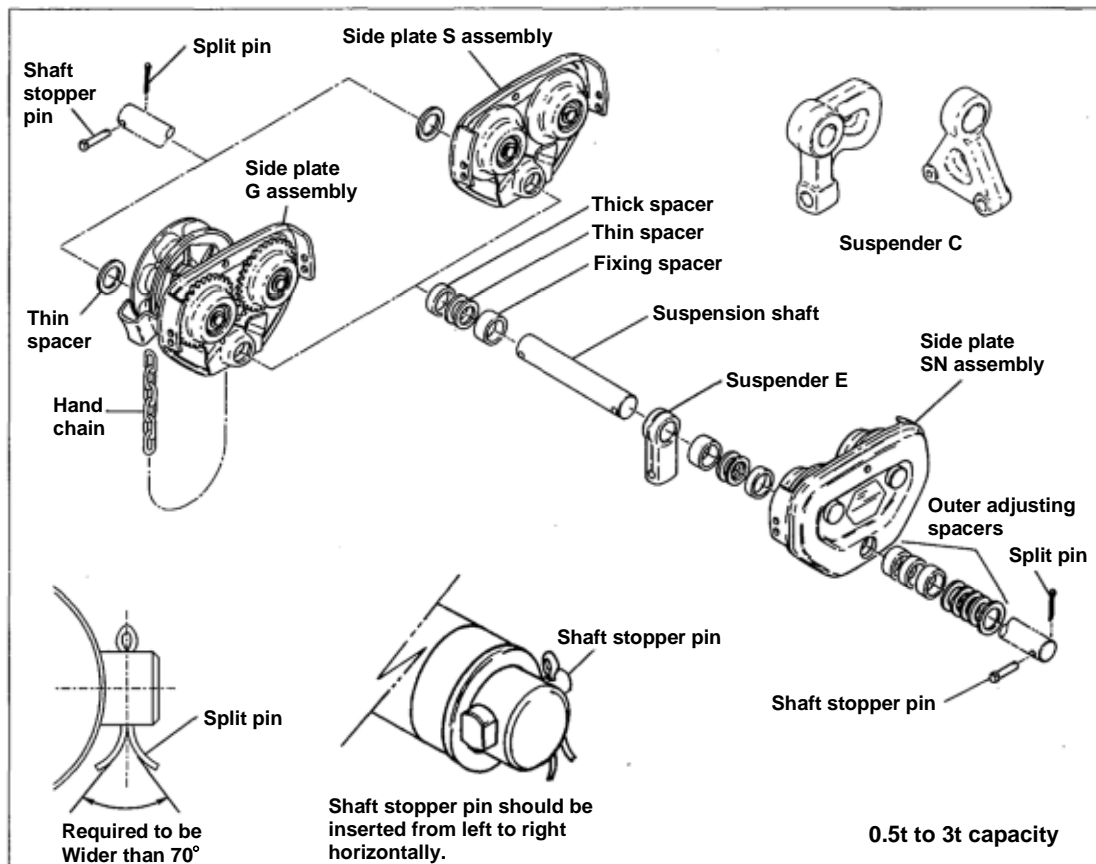
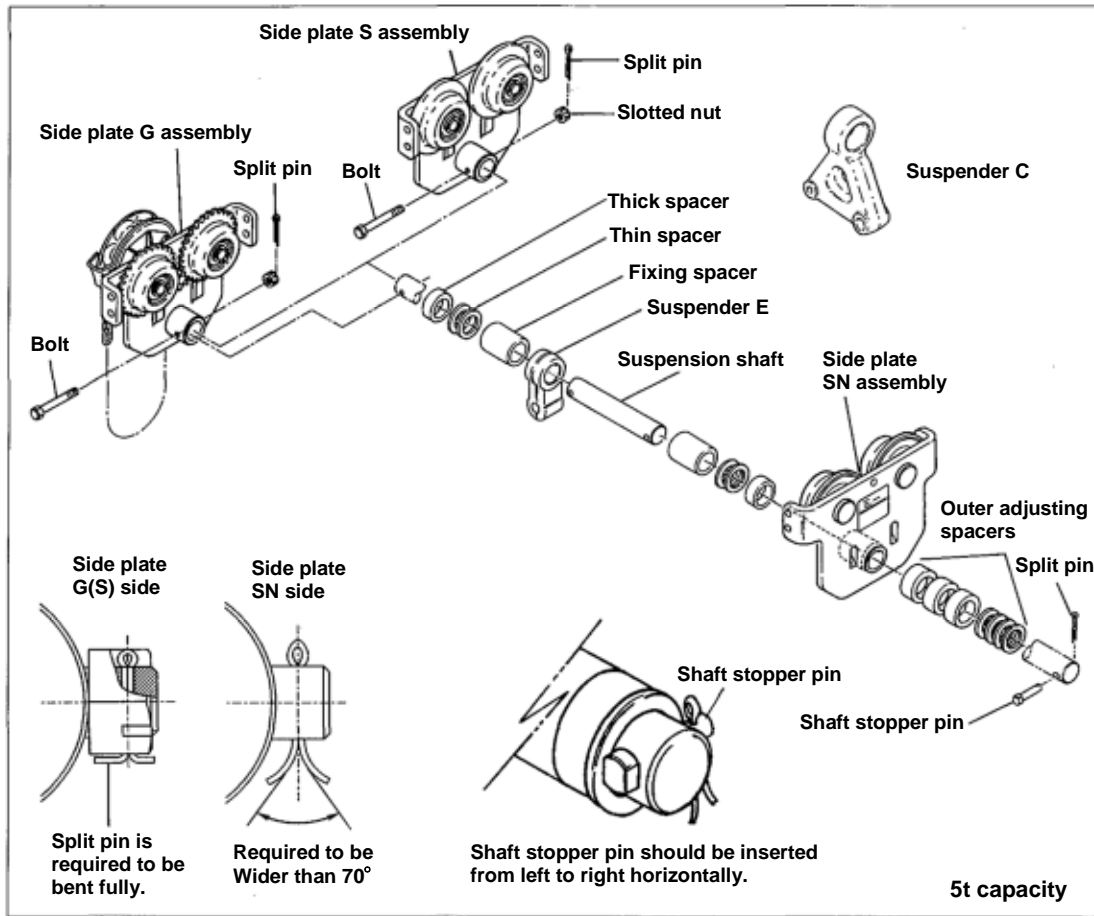

Fig. 16-2



7. BUFFER AND T-TYPE HANGER

7-1 Buffer

The side plates “S” and “G” have bumpers (lug) which prevent damage to the wheel and to the trolley. Buffers are available as an option.

7-1-1 Installation of buffer

Assemble as described below. Tighten the screw tightly, so the buffer cannot be moved by hand.

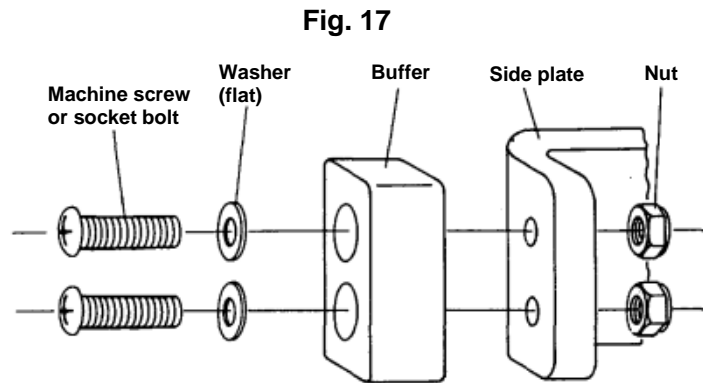

7-2 T-type hanger

A T-type hanger is used for moving the power supply cable while running together with the trolley on the same rail. When employing a T-type hanger, an additional fitting (cable pusher) is needed.

7-2-1 Installation of cable pusher

(1) Up to 3 t capacity

Fix the cable pusher by the M5 socket bolt with a spring washer from outside the side plate. When the power supply is on the right as shown in Fig. 18, place the cable pusher on the right side of the side plate.

When the power supply is on the left, turn the cable arm fitting 180° (upside-down direction) and re-install it. Then re-install the cable pusher on the left side of the side plate.

(2) 5 t capacity

Fix the cable arm with the bolt and spring washer into the $\varnothing 8$ mm hole of the side plate from inside. The method of installation depends on the direction of the power supply cable.

*When there are no taps or holes for installation of the cable pusher on the side plate, make them; referring to Fig. 20 and Table 7.

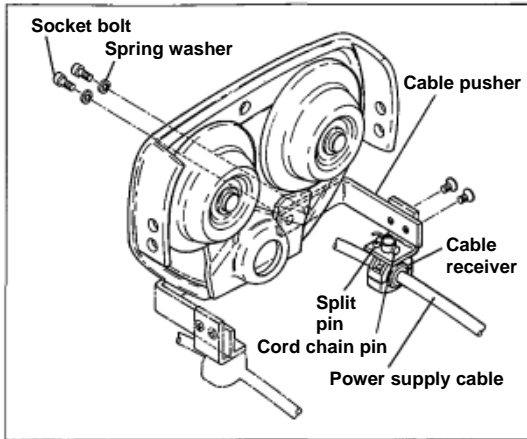

Fig. 18

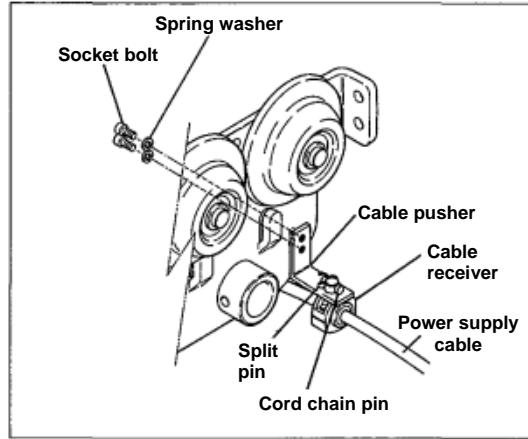

Fig. 19

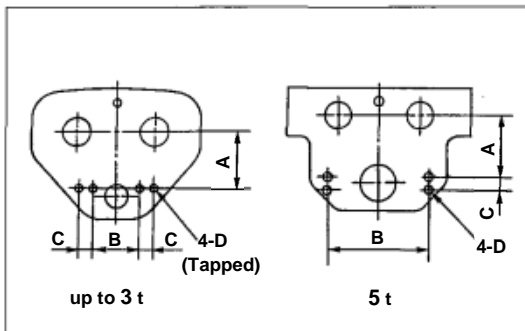

Fig. 20

	A	B	C	D
1/2t	62	50	15	M5
1t	75	80	15	M5
2t	86	80	22	M5
3t	93.5	124	22	M5
5t	142	242	19	$\varnothing 8.5$

Table 7

7-2-2 Installation of cable receiver

Install the cable receiver onto the hole ($\varnothing 14$ mm) from the bottom side of the cable pusher (cable arm) with a cord chain pin and a split pin. (Bend the split pin firmly). (Refer to Fig. 18 or 19.)

7-2-2 Installation of T-type hanger

(1) Type

There are 3 types. After adjusting the rail width as referred to in the table below, install the T-type hanger from the rail end. (See Fig. 21)

(2) Installation of T-type hanger

After adjusting beam width as refer to in table 8, install the required number of T-type hangers as shown in Fig. 22.

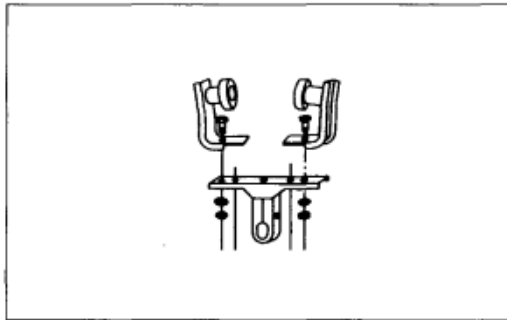

Fig. 21

Type	Beam Width (mm)
T-type hanger 200	76 to 102 (3" to 4")
T-type hanger 250	102 to 152 (4" to 6")
T-type hanger 275	127 to 178 (5" to 7")

Table 8

Note: Ask your authorized Kito dealer if the beam width exceeds 178 mm.

* The intervals between adjacent hangers.

In case of a straight beam or the larger radius curved beam, 2 m interval between hangers is adequate. In the case of smaller radius curved beam, closer interval gives smooth operation. For example, if the curve radius is about 1.5 m, about 1 m interval is adequate.

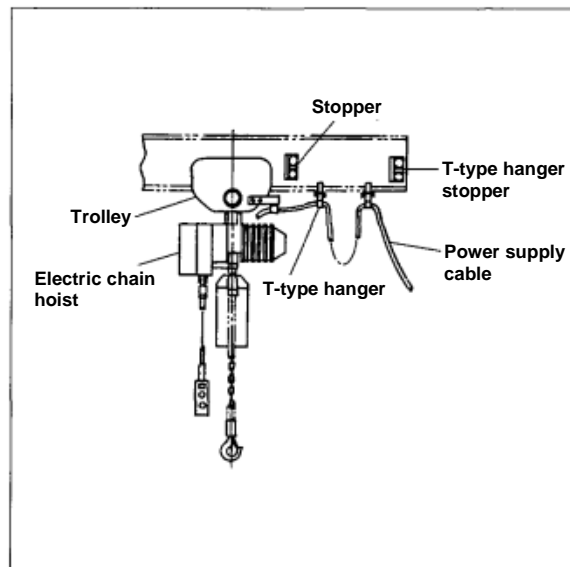

Fig. 22

8 WARRANTY

Kito Corporation ("Kito") extends the following warranty to the original purchaser ("Purchaser") of new products manufactured by "Kito" (Kito's Products).

- (1) "Kito" warrants that Kito's Products, when shipped, shall be free from defects in workmanship and/or materials under normal use and service and "Kito" shall, at the election of "Kito", repair or replace free of charge any parts or items which are proven to have said defects, provided that all claims for defects under this warranty shall be made in writing immediately upon discovery and, in any event, within one (1) year from the date of purchase of Kito's Products by "Purchaser" and provided, further, that defective parts or items shall be kept for examination by "Kito" or its authorized agents or returned to Kito's factory or authorized service center upon request by "Kito".
- (2) "Kito" does not warrant components of products provided by other manufacturers. However to the extent possible, "Kito" will assign to "Purchaser" applicable warranties of such other manufacturers.
- (3) Except for the repair or replacement mentioned in (1) above which is "Kito"'s sole liability and purchaser's exclusive remedy under this warranty, "Kito" shall not be responsible for any other claims arising out of the purchase and use of Kito's Products, regardless of whether "Purchaser"'s claims are based on breach of contract, tort or other theories, including claims for any damages whether direct, indirect, incidental or consequential.
- (4) This warranty is conditional upon the installation, maintenance and use of Kito's Products pursuant to the product manuals prepared in accordance with content instructions by "Kito". This warranty shall not apply to Kito's Products which have been subject to negligence, misuse, abuse, misapplication or any improper use or combination or improper fittings, alignment or maintenance.
- (5) "Kito" shall not be responsible for any loss or damage caused by transportation, prolonged or improper storage or normal wear and tear of Kito's Products or for loss of operating time.
- (6) This warranty shall not apply to Kito's Products which have been fitted with or repaired with parts, components or items not supplied or approved by "Kito" or which have been modified or altered.

THIS WARRANTY IS IN LIEU OF ALL OTHER WARRANTIES, EXPRESS OR IMPLIED, INCLUDING BUT NOT LIMITED TO ANY WARRANTY OF MERCHANTABILITY OR OF FITNESS FOR A PARTICULAR PURPOSE.

9 PARTS LIST

* When ordering replacement parts, please specify the following points.

1. Part name and trolley capacity.
2. Correct figure number.

Plain trolley (Rail width-standard)

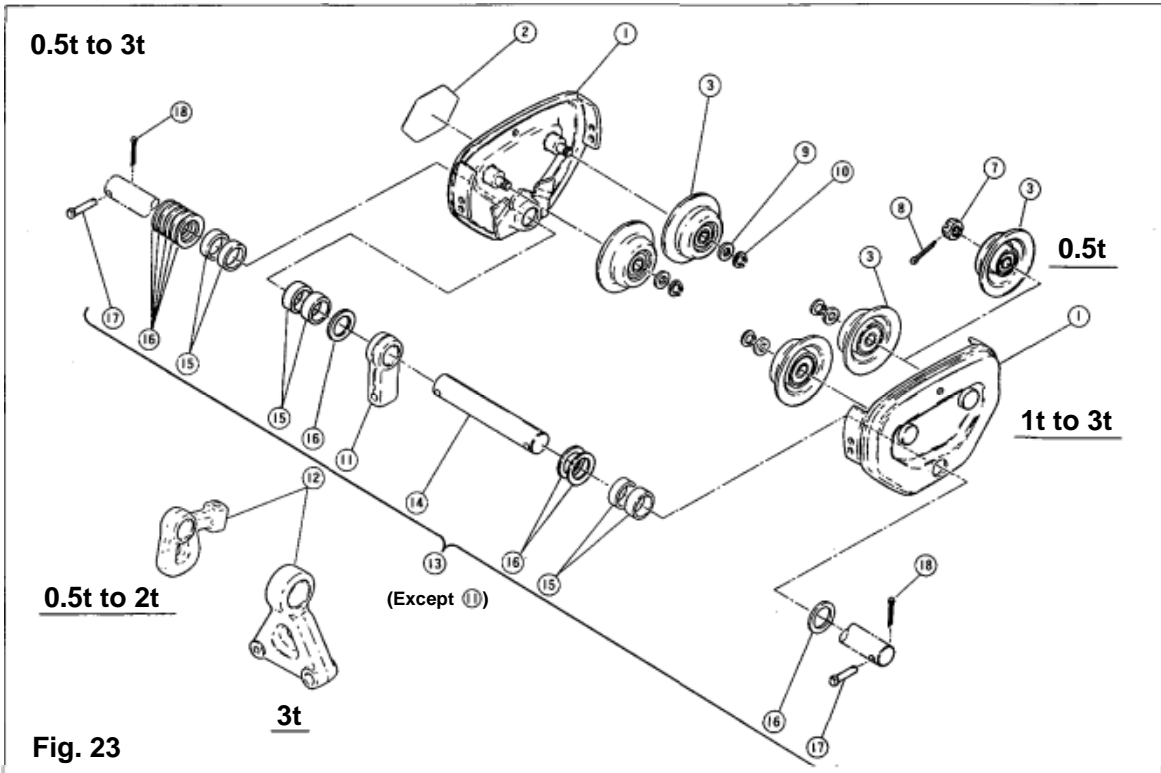

Fig. 23

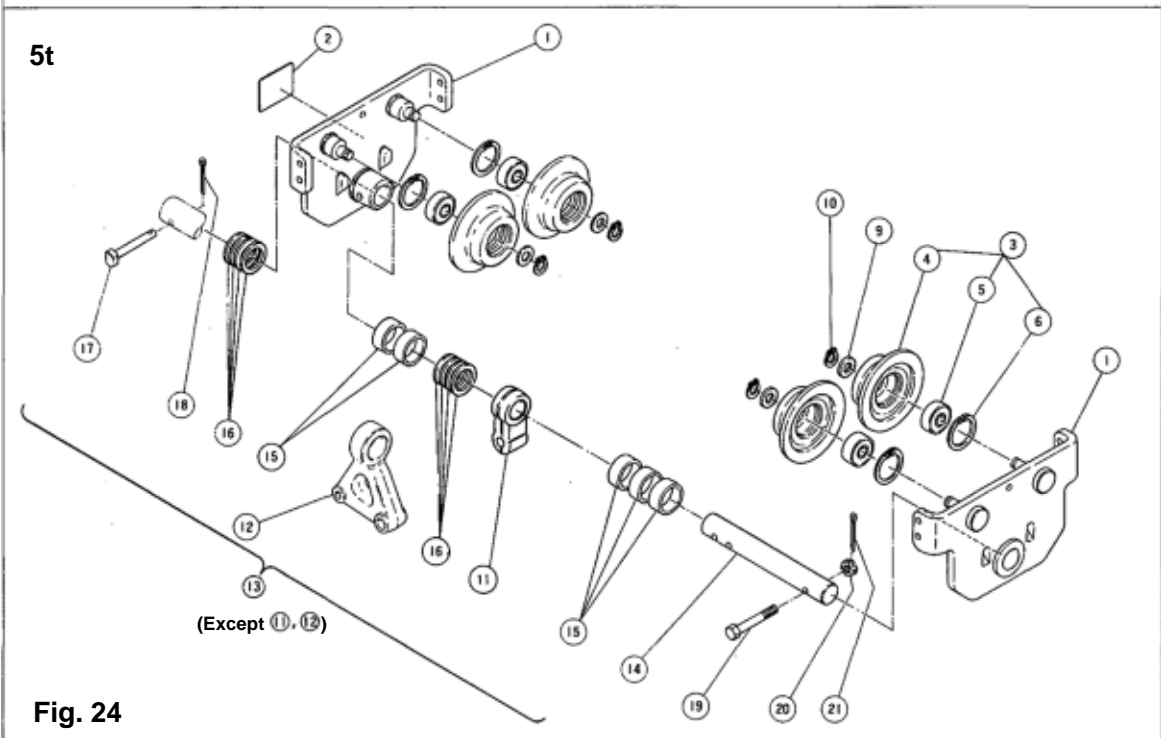

Fig. 24

Fig. No.	Part No.	Part Name	Nos. Per Trolley	Capacity					Remarks
				0.5t	1t	2t	3t	5t	
1		Side plate S Assembly	2					—	
		Side plate S Assembly	2	—	—	—	—		
2	T7G-800	Name plate B	1						
3	T6G-5102	Track wheel S Assembly	4					—	
	T3G-1102	Track wheel S Assembly	4	—	—	—	—		
4		Track wheel S	4	—	—	—	—		
5		Ball bearing	4	—	—	—	—	(6307ZZ)	
6		Snap ring	4	—	—	—	—	(R-80)	
7	T6P-158	Slotted nut	4	(L-M10)	—	—	—	—	
8	T6P-159	Split pin	4	(2x16)	—	—	—	—	
9	T6-104	Track wheel washer	4	—		(T1G-2')	(T1G-3')	(MS3-5')	
10	T6G-106	Snap ring	4	—	(S-15)	(S-20)	(S-25)	(S-35)	
11	T7GB-004	Suspender E	1					(MS3-5')	for Electric chain hoist
12	T7GC-004	Suspender C	1					(T5G-5')	for Manual chain hoist
13	T7G-1115	Suspension shaft (standard) Assembly	1						
14	T7G-115	Suspension shaft (standard)	1						
15	T7G-116	Thick spacer	*					(T1G-5')	
16	T6G-117	Thin spacer	**					—	
	T7G-120		8	—	—	—	—		
17	T6G-156	Shaft stopper pin	2 (1)					(MS3-5')	(1) for 5t
18	T6G-157	Split pin	2 (1)	(3.2x20)		(4x20)		(4x22)	(1) for 5t
19	T4G-154	Suspension shaft bolt	1	—	—	—	—	(MS3-5')	
20	T4G-155	Slotted nut	1	—	—	—	—	(L-M12)	
21	T4G-156	Split pin	1	—	—	—	—	(3x22)	

Note : * 4p'cs for 0.5t, 6p'cs for 1t • 2t, 9p'cs for 3t, 5p'cs for 5t.

** 10p'cs for 0.5t, 9p'cs for 1t, 8p'cs for 2t, 11p'cs for 3t.

Geared trolley (Rail width standard)

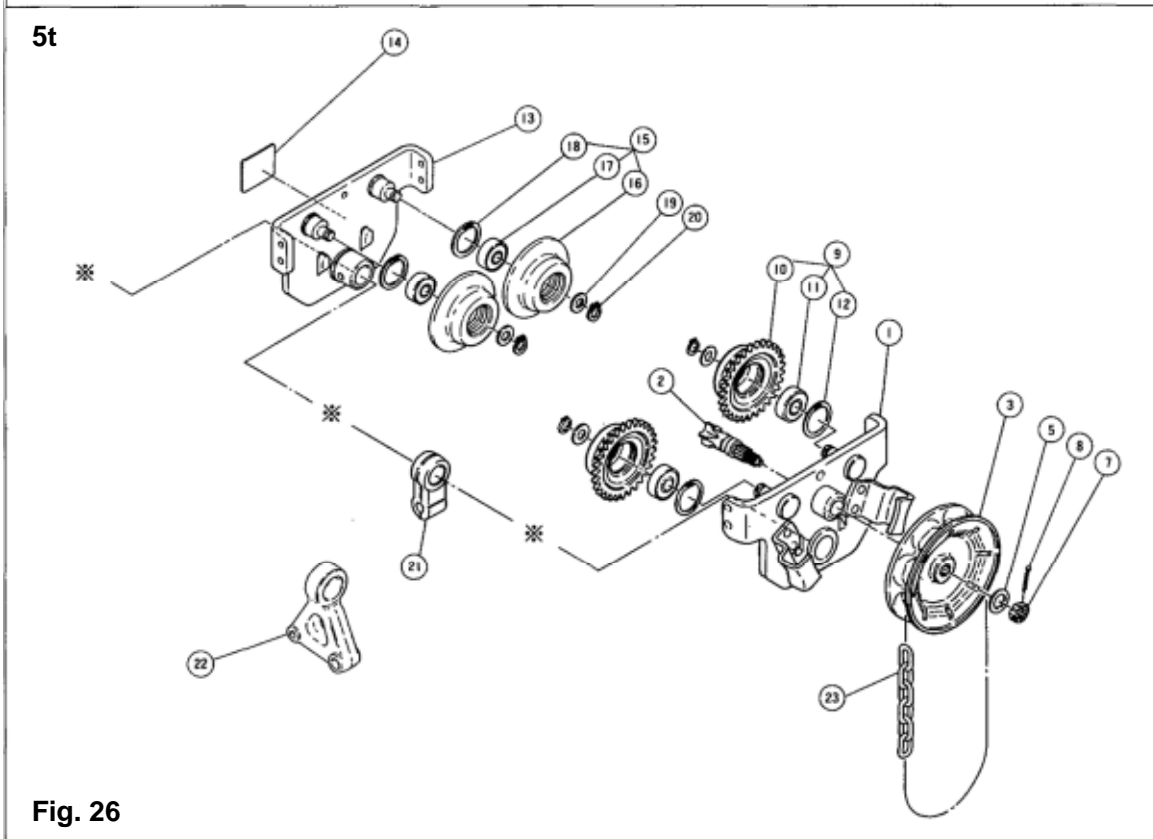
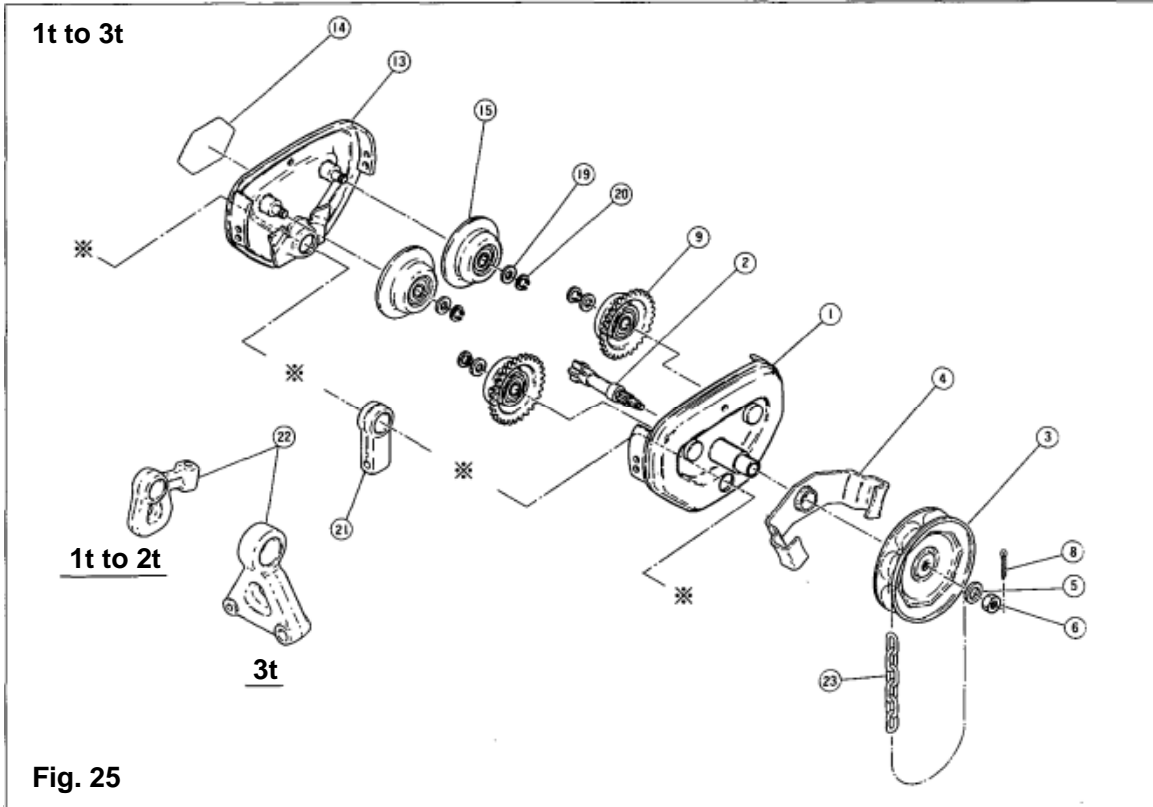

Note: * Refer to the parts list of plain trolley for suspender assembly.

Fig. No.	Part No.	Part Name	Nos. Per Trolley	Capacity				Remarks
				1t	2t	3t	5t	
1		Side plate G Assembly	1				—	
		Side plate S Assembly	1	—	—	—		
2	T7GB-121	Pinion	1	—			(TAGB-1 ¹)	
			1		—	—	—	for Electric chain hoist
	T7GC-127	Pinion	1		—	—	—	for Manual chain hoist
3	T6G-123	Hand wheel	1				—	
	T7G-123		1	—	—	—		
4	T6G-5125	Hand chain guide Assembly	1				—	
5	T7G-152	Washer	1	(L-M12)				
6	T7G-151	Lever nut	1	(M2-40 ¹)			—	
7	T4G-151	Slotted nut	1	—	—	—	(L-M12)	
8	T7G-160	Split pin	1	(3x18)			(3x22)	
9	T6G-5101	Track wheel G Assembly	2	—	—	—		
	T3G-1102	Track wheel G Assembly	2	—	—	—		
10		Track wheel G	2	—	—	—		
11		Ball bearing	2	—	—	—	(6307ZZ)	
12		Snap ring	2	—	—	—	(R-80)	
13		Side plate S Assemblyt	1				—	
		Side plate S Assembly	1	—	—	—		
14	T7G-800	Name plate B	1					
15	T6G-5102	Track wheel Assembly	2				—	
	T3G-1102	Track wheel S Assembly	2	—	—	—		
16		Track wheel S	2	—	—	—		
17		Ball bearing	2	—	—	—	(6307ZZ)	
18		Snap ring	2	—	—	—	(R-80)	
19	T6G-104	Track wheel washer	4		(T1G-2 ¹)	(T1G-3 ¹)	(MS3-5 ¹)	
20	T6G-106	Snap ring	4	(S-15)	(S-20)	(S-25)	(S-35)	
21	T7GB-004	Suspender E	1				(MS3-5 ¹)	for Electric chain hoist
22	T7GC-004	Suspender C	1				(TS1-5 ¹)	for Manual chain hoist
23	T7G-842	Hand chain	1	(2.5m)	(3m) * 2.5m for 1.5t		(3.5m)	for Manual chain hoist

Rail width-option

Suspension shaft W20 Assembly. (0.5t,1t)

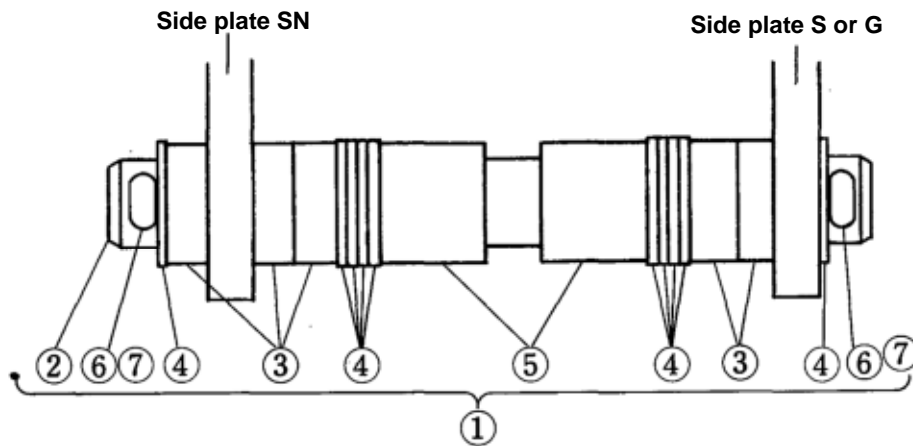

Fig. 27

Suspension shaft W30 Assembly. (0.5t to 1t)

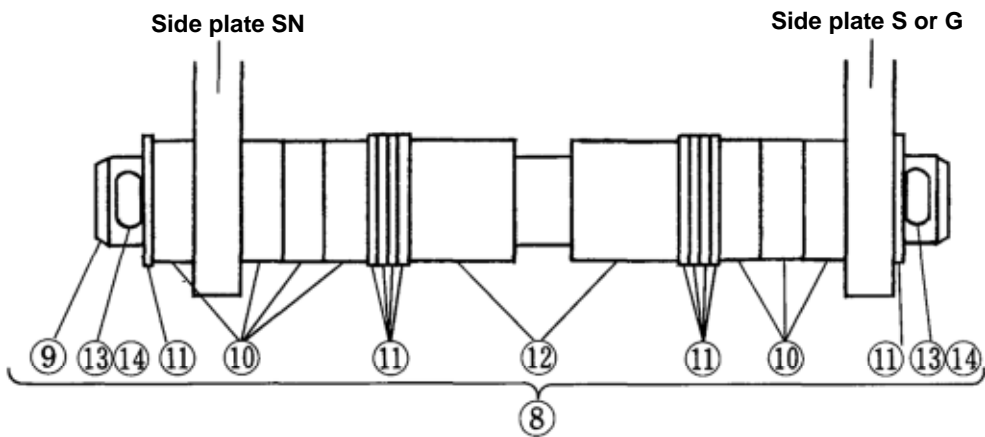

Fig. 28

Suspension shaft W30 Assembly. (5t)

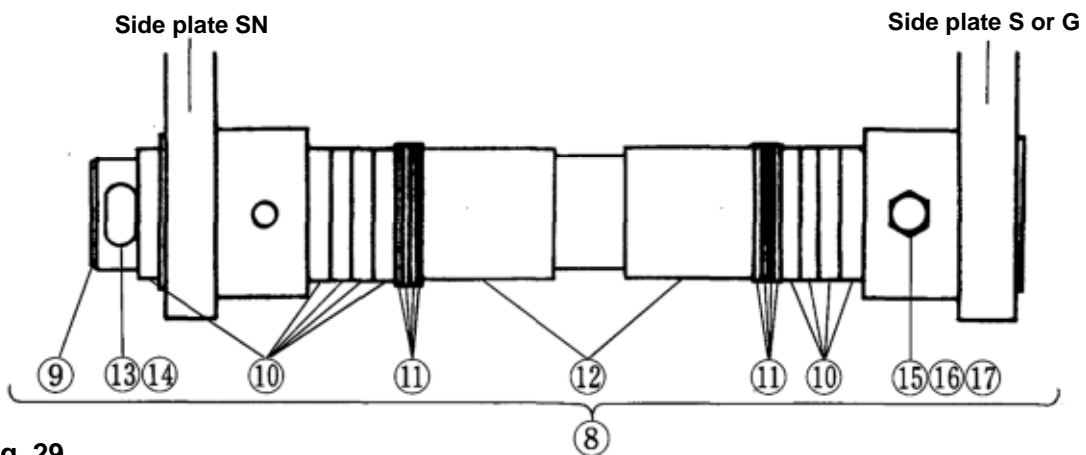

Fig. 29

Fig. No.	Part No.	Part Name	Nos. Per Trolley	Capacity					Remarks
				0.5t	1t	2t	3t	5t	
1	T7G-136	Suspension shaft W20 Assembly	1			—	—	—	
2	T7G-136	Suspension shaft W20	1			—	—	—	
3	T7G-116	Thick spacer	*			—	—	—	
4	T6G-117	Thin spacer	10			—	—	—	
5	T7G-137	Fixing spacer W20	2			—	—	—	
6	T6G-156	Shaft stopper pin	2			—	—	—	
7	T6G-157	Split pin	2	(3.2x20)					
8	T7G-1181	Suspension shaft W30 Assembly	1	(L-M10)	—	—	—	—	
9	T7G-181	Suspension shaft W30	1						
10	T7G-116	Thick spacer	**					(T1G-5 ^l)	
11	T6G-117	Thin spacer	10					—	
	T7G-120		8	—	—	—	—		
12	T7G-182	Fixing spacer W30	2						
13	T6G-156	Shaft stopper pin	2 (1)				(MF2-2 ^l)	(MS3-5 ^l)	(1) for 5t
14	T6G-157	Split pin	2 (1)	(3.2x20)		(4x20)		(4x22)	(1) for 5t
15	T4G-154	Shaft stopper pin	1	—	—	—	—	(MS3-5 ^l)	
16	T4G-155	Slotted nut	1	—	—	—	—	(L-M12)	
17	T4G-156	Split pin	1	—	—	—	—	(3x22)	

Note : * 7p'cs for 0.5t, 5p'cs for 1t.

** 7p'cs for 0.5t · 1t, 11p'cs for 2t · 3t, 9p'cs for 2t, 11p'cs for 3t.

KITO[®]

Website : kitocrosby.com