



MR2 Series Motorized Trolley (125kg to 5t)

Parts List

Contents

Contents	2
Introduction	2
Frame and Wheel related	3
Suspension shaft related	3
Motor related	4
Gear related.....	4
Connection box related (Single speed type).....	5
Connection box related (Dual speed inverter (VFD) type).....	7
Connection box related (Dual speed, 500V Class).....	9
Push button related	11
Power supply cable and Accesory related/Trolley cable related.....	12

Introduction

Target products

Product code

The parts lists show the related parts for the MR2 Series Motorized Trolley. The types of the target products are as shown below. For the parts of the hoist, refer to ER2 Series Electric Chain Hoist Parts List.

Capacity	CODE		
	Single speed model		Dual speed model
	Standard speed	Low speed	Standard speed
125kg	MR2-010S	MR2-010L	MR2-010IS/SD
250kg			
500kg			
1t	MR2-020S	MR2-020L	MR2-020IS/SD
1.5t			
2t			
2.5t	MR2-030S	MR2-030L	MR2-030IS/SD
2.8t			
3t			
5t	MR2-050S	MR2-050L	MR2-050IS/SD

Product category and voltage

The product has four categories for power supply voltages.

Product category	Motor Insulation Class	Voltage range		Operating Voltage
		50Hz	60Hz	
230V Class	B	220V	220V	24V (24V to 26.4V)
		230V	230V	
400V Class	F	380V	380V	
		400V	440V	
		415V	-	
500V Class	B	500V	575V	
230/460V Class		208-230V	110V (110V to 120V)	
	415-460V			

Interpretation of parts lists

- Match the number in the 3D diagram with "In Diagram" in the parts list to obtain the part name.
 - Cells with an x-mark at intersection of Part name and product code in the parts table are not used.
 - Blank cells at the intersection of Part name and product code in the parts table vary the part number depending on the power supply voltage.
 - For the cells with an arrow mark, the product code listed in the left cell should be applied.
- If you need a part for the blank cell, let us know the product code shown in the preceding item, power supply voltage and part number.

Push button cord complete set

When ordering a push button cord complete set, let us know the cord length referring to the following table.

Capacity	Push button cord length	
	Direct connection	Plug connection
125kg - 2.5t	same as Lift(m)	Lift(m)-0.2m
2.8t - 5t	Lift(m)+0.3m	Lift(m)+0.1m

How to order

- When ordering, let us know the product code, voltage, Part name, Part number and quantity.
- For part price and delivery date, contact our distributor or KITO.

Frame and Wheel related/Suspension shaft related

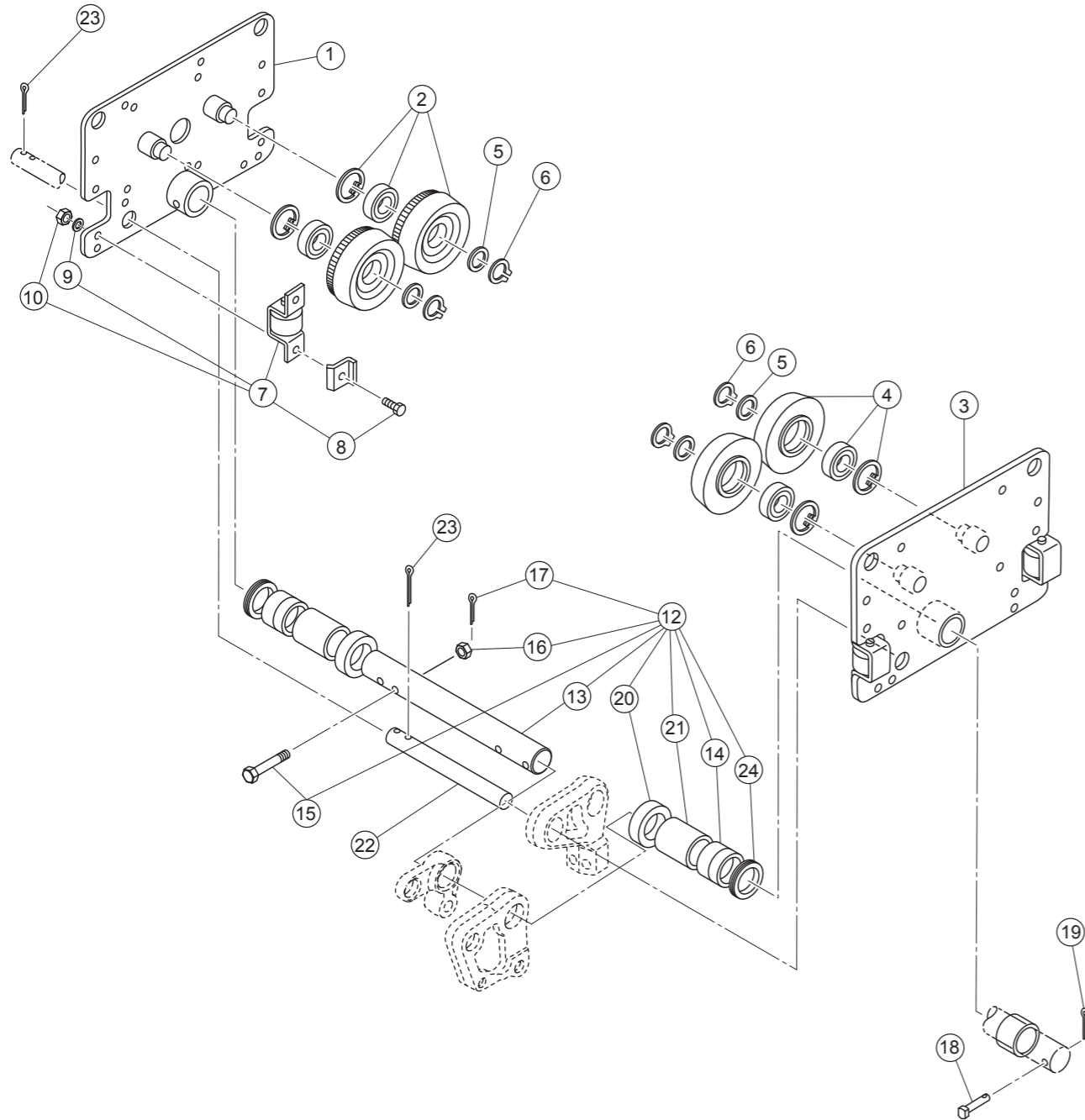

Frame and Wheel related/Suspension shaft related

Frame and Wheel related

Figure No.	Part Number	Part Name	Quantity per unit	Product code				Remark
				MR2-010 S/L/IS/SD	MR2-020 S/L/IS/SD	MR2-030 S/L/IS/SD	MR2-050 S/L/IS/SD	
1	5201	Side Plate G assembly	1	MR1DS5201	MR1ES5201	MR1FS5201	MR1GS5201	
2	1231	Track wheel G assembly	2	M6SE010S1101	M6SE020S1101	M6SE030S1101	M7SE050S1101	
3	5202	Side Plate S assembly	1	MR1DS5202	MR1ES5202	MR1FS5202	MR1GS5202	
4	1232	Track wheel S assembly	2	M6SE010S1102	M6SE020S1102	M6SE030S1102	M7SE050S1102	
5	235	Washer	4	T6GA010-9104	T1GA020-9104	T1GA030-9104	M6SE050S9104	For track wheel G, S
6	236	Snap ring	4	J1SS000-00015	J1SS000-00020	J1SS000-00025	J1SS000-00035	For track wheel G, S
7	1211	Side roller complete set	4	MR1DS1211SU_01	MR1ES1211SU_01	←	MR1GS1211SU_01	
8	219	Bolt	8	J1BA1-0803030	J1BA1-1003535	←	J1BA1-1604545	
9	220	Spring lock washer	8	J1WS011-20080	J1WS011-20100	←	J1WS011-20160	
10	221	Nut	8	J1NA001-20080	J1NA001-20100	←	J1NA001-20160	

Suspension shaft related

Figure No.	Part Number	Part Name	Quantity per unit				Product code				Remark
			MR2-010	MR2-020	MR2-030	MR2-050	MR2-010 S/L/IS/SD	MR2-020 S/L/IS/SD	MR2-030 S/L/IS/SD	MR2-050 S/L/IS/SD	
12	2101	Suspension shaft complete set	1	1	1	1	MR1DS2111	MR1ES2111	MR1FS2111	MR1GS1111	
13	101	Suspension shaft	1	1	1	1	M7SE010S9115	M7SE020S9115	MR1FS9101	MR1GS9101	
14	102	Thick spacer	5	5	5	3	T4GA010-9116	T7GA030-9116	T4GA030-9116	T1GA050-9116	
15	103	Bolt	1	1	1	1	T1GA010-9153	M6FE020S9161	T1GA030-9153	M6SE050S9161	
16	104	Slotted nut	1	1	1	1	J1NL002-10100	J1NL002-10100	J1NL002-20120	J1NL002-20120	
17	105	Split pin	1	1	1	1	J1PW01-025018	J1PW01-025018	J1PW01-030022	J1PW01-030022	
18	106	Shaft stopper	1	1	1	1	T6GA020-9156	M6FE020S9164	M6SE030S9164	M6SE050S9164	
19	107	Split pin	1	1	1	1	J1PW02-040020	J1PW02-040020	J1PW02-040022	J1PW02-040022	
24	109	Thin spacer	8	8	8	8	T6GA020-9117	T6GA030-9117	T6GD050-9120	M7SS050S9117	
20	110	Thick spacer L	2	2	2	2	MR1DS9110	MR1ES9110	MR1FS9110	MR1GS9110	
12	1121	Suspension shaft complete set (300)	1	1	1	1	MR1DS1112	MR1ES1112	MR1FS1112	MR1GS1112	
13	101	Suspension shaft (300)	1	1	1	1	M7SE010S9181	M7SE020S9181	MR1FS9121	MR1GS9121	
14	102	Thick spacer	9	9	9	13	T4GA010-9116	T7GA030-9116	T4GA030-9116	T1GA050-9116	
15	103	Bolt	1	1	1	1	T1GA010-9153	M6FE020S9161	T1GA030-9153	M6SE050S9161	
16	104	Slotted nut	1	1	1	1	J1NL002-10100	J1NL002-10100	J1NL002-20120	J1NL002-20120	
17	105	Split pin	1	1	1	1	J1PW01-025018	J1PW01-025018	J1PW01-030022	J1PW01-030022	
18	106	Shaft stopper	1	1	1	1	T6GA020-9156	M6FE020S9164	M6SE030S9164	M6SE050S9164	
19	107	Split pin	1	1	1	1	J1PW02-040020	J1PW02-040020	J1PW02-040022	J1PW02-040022	
24	109	Thin spacer	8	8	8	8	T6GA020-9117	T6GA030-9117	T6GD050-9120	M7SS050S9117	
20	110	Thick spacer L	2	2	2	2	MR1DS9110	MR1ES9110	MR1FS9110	MR1GS9110	
21	108	Fixing spacer (300)	2	2	2	x	M7SE010S9182	M7SE020S9182	M7SE030S9182	x	
22	131	Fixing shaft	1	1	1	1	MR1DS9131	MR1ES9131	MR1FS9131	MR1GS9131	For standerd beam
	141	Fixing shaft	1	1	1	1	MR1DS9141	MR1ES9141	MR1FS9141	MR1GS9141	For wide beam
23	132	Split pin	2	2	2	2	J1PW02-050040	J1PW02-050040	J1PW02-050050	J1PW02-050050	For fixing shaft

Motor related/Gear related

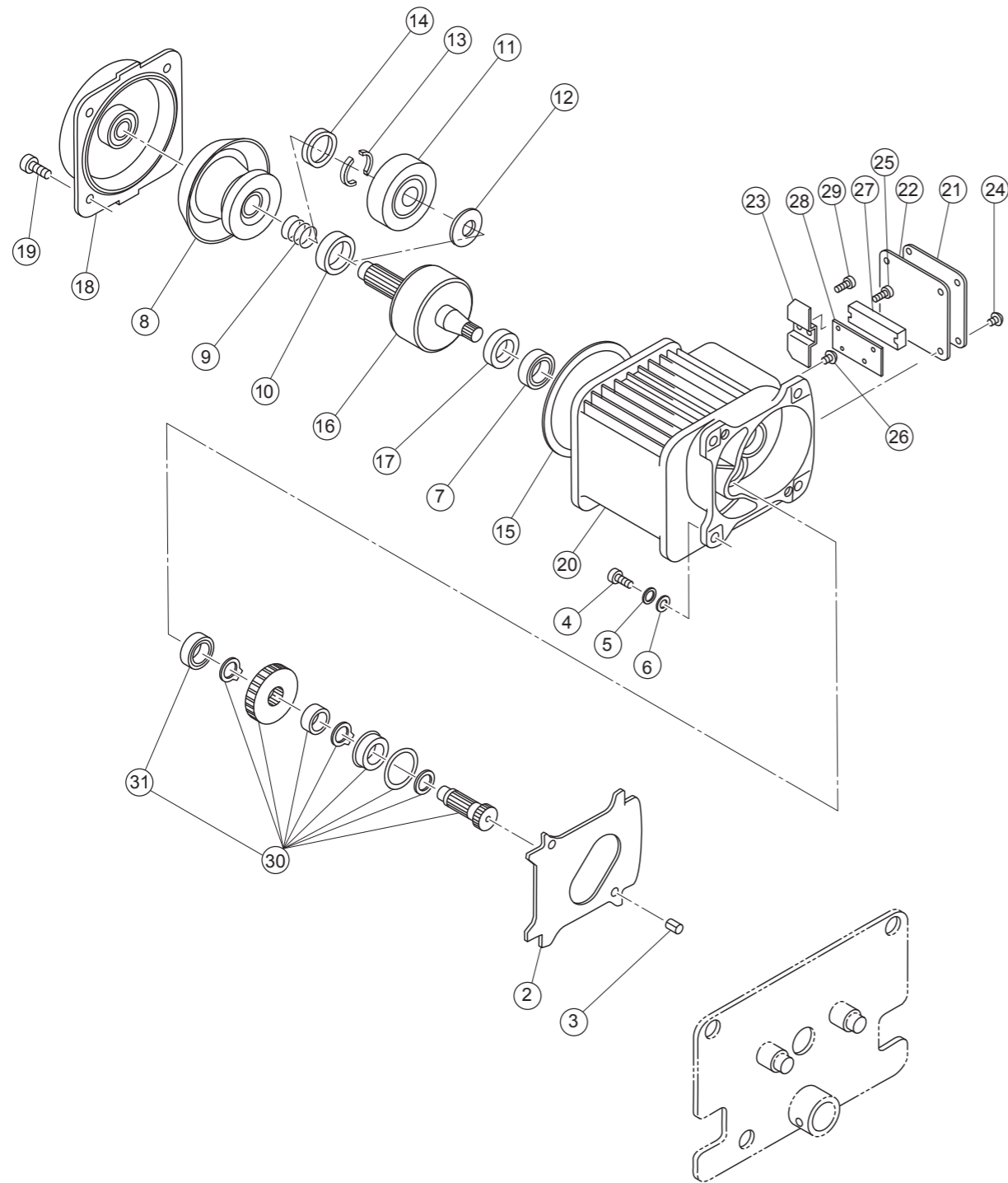

Motor related/Gear related

Motor related

Figure No.	Part Number	Part Name	Quantity per unit	Product code		Remark
				MR2-010S/L/IS/SD MR2-020S/L/IS/SD MR2-030S/L/IS/SD	MR2-050S/L/IS/SD	
2	248	Gear frame packing	1	MR1DS9248	MR1DS9248	
3	249	Set pin	2	MR1DS9249	MR1DS9249	For gear frame and frame G
4	250	Bolt	4	J1BA1-0802525	J1BA1-0802525	For gear frame. Integrated type with spring/flat washer is available. (251 and 252 are not necessary.)
5	251	Spring lock washer	4	J1WS011-20080	J1WS011-20080	For gear frame
6	252	Washer	4	J1WA011-00080	J1WA011-00080	For gear frame
7	253	Ball bearing	1	J1GR0C0-06204	J1GR0C0-06204	For gear frame on motor side
8	5261	Brake drum assembly	1	MR1DS5261 MR1DB5261	MR1DS5261 MR1DB5261	500V Class dual speed
9	264	Brake spring	1	M3ES010-9304 MR1DB9264	M3ES010-9304 MR1DB9264	500V Class dual speed
10	265	Bumper	1	MR1DS9265	MR1DS9265	For single speed
11	271	Pull rotor	1	E5FE005S9503	E5FE005S9503	500V Class dual speed
12	272	Coned disc spring	1	E5FE005S9504	E5FE005S9504	500V Class dual speed
13	273	Thrust disc	2	E5FE005S9505	E5FE005S9505	500V Class dual speed
14	274	Thrust collar	1	E5FE005S9506	E5FE005S9506	500V Class dual speed
15	281	Guard	1	MR1DS9281	MR1DS9281	
16	5291	Motor shaft with rotor	1	MR1DS5291 MR1DB5291 MR1FB5291	MR1DS5291 MR1FB5291 x	500V Class dual speed 030SD, For 500V Class dual speed
17	293	Oil seal	1	MR1DS9293	MR1DS9293	
18	1301	Motor cover assembly	1	MR1DS1301	MR1DS1301	
19	304	Socket bolt	4	J1BE2-0802222	J1BE2-0802222	For motor cover
20	5321	Motor frame with stator	1	MR2SJC10S5A2 MR2SJY10S5A2 MR2SKK10S5A2 MR2SKV10S5A2 MR2SKK10B5A2 MR2SKK30B5A2	MR2SJC50S5A2 MR2SJY50S5A2 MR2SKK50S5A2 MR2SKV50S5A2 MR2SKK30B5A2 x	230V Class 400V Class 500V Class 230/460V Class 500V Class dual speed 030SD, For 500V Class dual speed
21	324	Terminal cover	1	M6FE005S9206 M7SE010B9206	M7SE010B9206 M7SE010B9206	500V Class dual speed
22	325	Terminal cover packing	1	MR1DS9325 MR1GS9325	MR1GS9325 MR1GS9325	500V Class dual speed
23	326	Coil cover	1	MR1DS9326	MR1DS9326	
24	331	Machine screw with spring washer	4	J1AP2-5001010	J1AP2-5001010	For terminal cover
25	332	Machine screw with spring washer	2	J1AW2-4002020 J1AW2-4001212	← ←	For terminal 6P For terminal 6P 500V Class , 230/460V Class
26	334	Machine screw with spring washer	1	J1AP2-4000808	J1AP2-4000808	For ground
27	851	Terminal 6P	1	M6FE005S9516 ECP1306AB	← ←	500V Class , 230/460V Class
28	855	Terminal plate holder	1	MR1DS9855	←	500V Class , 230/460V Class
29	857	Flat head screw	2	J1AL2-4001010	←	For terminal plate holder

Gear related

Figure No.	Part Number	Part Name	Quantity per unit	Product code								Remark
				MR2-010S/IS	MR2-010L MR2-010SD	MR2-020S/IS	MR2-020L MR2-020SD	MR2-030S/IS	MR2-030L MR2-030SD	MR2-050S/IS	MR2-050L MR2-050SD	
30	1241	Gear complete set	1	MR1DS1241	MR1DL1241	MR1ES1241	MR1EL1241	MR1ES1241	MR1EL1241	MR1GS1241	MR1GL1241	
31	247	Ball bearing	1	J1GR0B0-06002								For gear #3 on gear frame side

Connection box related (Single speed type)

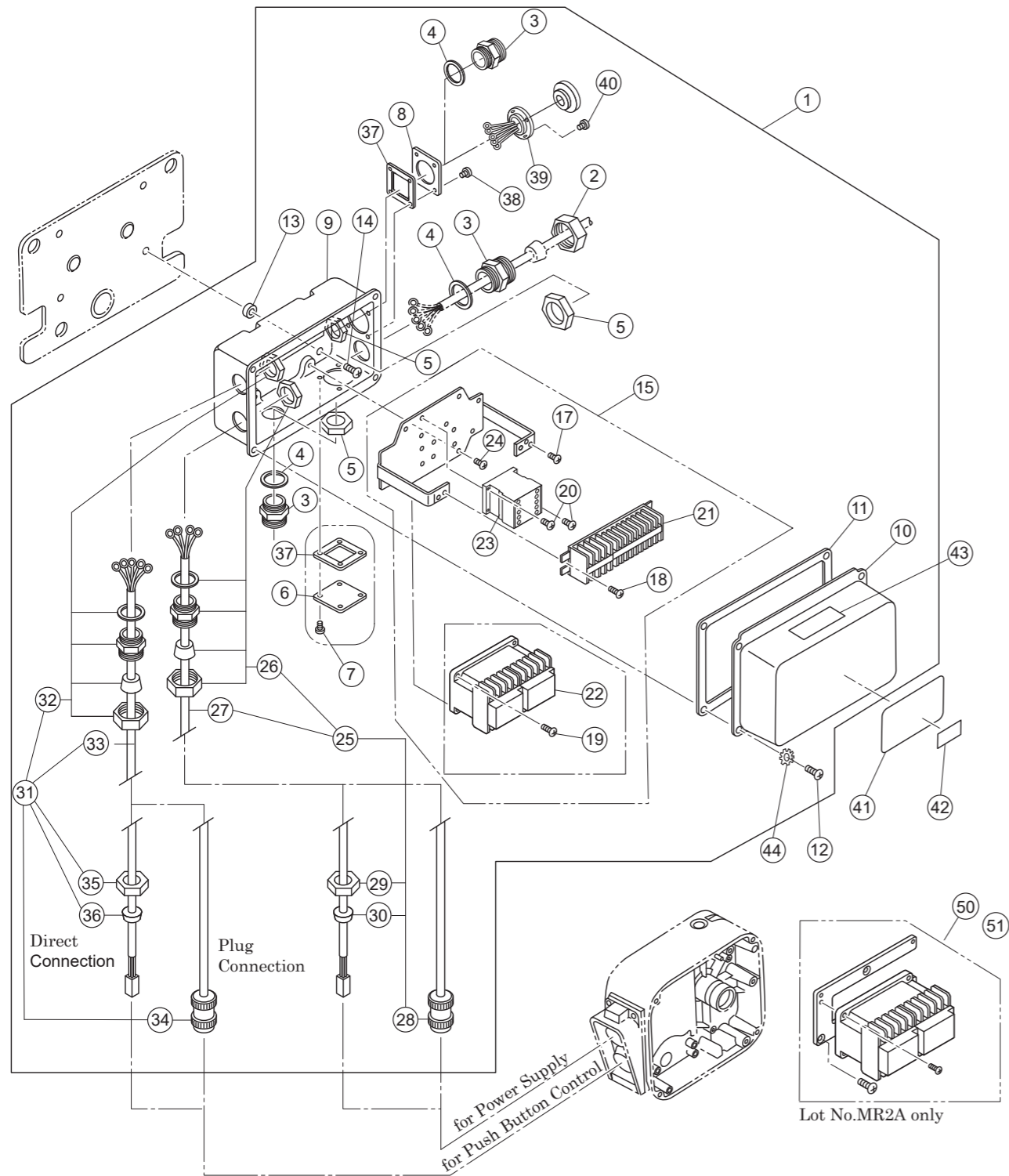

Connection box related (Single speed type)

Figure No.	Part Number	Part Name	Quantity per unit	Product code				Remark
				MR2-010S/L	MR2-020S/L	MR2-030S/L	MR2-050S/L	
1	1401	Connection box complete set	1	MR2REE10M1A4	MR2REE20M1A4	←	←	500V Class 230/460V Class For Direct connection
				MR2RFC10M1A4	MR2RFC20M1A4	←	←	
				MR2RHM10M1A4	MR2RHM20M1A4	←	←	
				MR2RSC10M1A4	MR2RSC20M1A4	←	←	
2	341	Holder A	1	ECP5924AA	←	←	←	
3	342	Holder B	2/3	ECP5924AB	←	←	←	Direct connection provides 3 pieces
4	343	Packing	2/3	ECP5924AC	←	←	←	Direct connection provides 3 pieces
5	344	Holder nut	2/3	ECP5924AD	←	←	←	Direct connection provides 3 pieces
6	347	Cord cover	1	E6LE10S9630	←	←	←	
7	348	Machine screw with spring washer	4	J1AP2-5001010	←	←	←	For Cord cover
8	346	Plate P	1	ECP5924AH	←	←	←	For Plug connection
	349	Plate D		ECP5924AF	←	←	←	For Direct connection
9	401	Connection box	1	MR1DS9401	←	←	←	
10	411	Connection box cover	1	MR1DS9411	←	←	←	
11	421	Connection box packing	1	MR1DS9421	←	←	←	
13	423	Spacer	4	M6SE010S9517	←	←	←	
14	424	Machine screw with spring washer	4	J1AP2-8002020	←	←	←	For Connection box assemble
15	1445	Plate complete set	1	MR2REE10M1A5	←	←	←	500V Class 230/460V Class For Direct connection
				MR2RFC10M1A5	←	←	←	
				MR2RHM10M1A5	←	←	←	
				MR2REE10M1A5	←	←	←	
17	451	Machine screw with spring washer	3	J1AP2-4000808	←	←	←	For earth
18	452	Machine screw with spring washer	2	J1AW2-4001212	←	←	←	For Terminal
19	453	Machine screw with spring washer	2	J1AP2-4001616	←	←	←	For Electromagnetic contactor 871 For MGC22302A, MGC22306B, MGC23306C
				J1AP2-4001212	←	←	←	For Electromagnetic contactor 871 For MGC22312A, MGC22316A
20	457	Machine screw with spring washer	2	J1AP2-4001212	←	←	←	For Electromagnetic contactor 873
21	853	Terminal 16P	1	ECP1416AA	←	←	←	
22	871	Electromagnetic contactor	1	MGC22302A	←	←	←	For traveling For Lot No. MR2A ¹
				MGC23312A	←	←	←	For Lot No. MR2B, MR2C
				MGC22306B	←	←	←	For Lot No. MR2A ² 230/460V Class
				MGC23306C	←	←	←	For Lot No. MR2C 230/460V Class
23	873	Electromagnetic contactor	1	MGC12302A	←	←	←	For emergency stop For Lot No. MR2A, MR2B
				MGC12302B	←	←	←	For Lot No. MR2C
				MGC12306B	←	←	←	For Lot No. MR2A 230/460V Class
				MGC12306C	←	←	←	For Lot No. MR2C 230/460V Class
24	454	Machine screw with spring washer	4	J1AP2-5001010	←	←	←	230/460V Class
25	1751	Relay cable P assembly	1	MR2DS1751	MR2ES1751	←	←	For Lot No. MR2C
				MR2DS1759	MR2ES1759	←	←	230/460V Class
				MR2DS2751	MR2ES2751	←	←	For Direct connection
26	1602	Holder assembly	1	ECP5924BA	ECP5924BB	←	←	230/460V Class
				ECP5924BA	ECP5924BC	←	←	
27	751	Cable	1	Z2CU401-0000	Z2CU402-0000	←	←	230/460V Class
				ZDCC401-0000	ZDCC402-0000	←	←	

Connection box related (Single speed type)

Figure No.	Part Number	Part Name	Quantity per unit	Product code				Remark
				MR2-010S/L	MR2-020S/L	MR2-030S/L	MR2-050S/L	
28	752	Plug 4P	1	ECP2304AD	ECP2304AE	←	←	230/460V Class
				ECP2304AD	ECP2304AF	←	←	
29	341	Holder A	1	ECP5924AA	←	←	←	For Direct connection
30	351	Cable packing	1	ECP6912AA	ECP6914AA	←	←	For Direct connection
31	1761	Relay cable S assembly	1	MR2DS1761	MR2ES1761	←	←	For Operation
				MR2DS1768	MR2ES1768	←	←	230/460V Class
				MR2DS2761	MR2ES2761	←	←	For Direct connection
32	1602	Holder assembly	1	ECP5924BB	←	←	←	230/460V Class
				ECP5924BC	←	←	←	
33	761	Cable	1	Z2CR601-0000	←	←	←	230/460V Class
				ZDCK601-0000	←	←	←	
34	762	Plug 8P	1	ECP2108AB	←	←	←	230/460V Class
				ECP2108AC	←	←	←	
35	341	Holder A	1	ECP5924AA	←	←	←	For Direct connection
36	351	Cable packing	1	ECP6914AA	←	←	←	For Direct connection
37	818	Cord cover packing	2	M7SE010S9527	←	←	←	
38	820	Machine screw with spring washer	4	J1AP2-5001010	←	←	←	For Plate P, D
39	5811	Socket 8P assembly	1	MR2DS5811	←	←	←	230/460V Class
				MR2DS6811	←	←	←	
40	814	Flat head machine screw	4	J1AL2-4001212	←	←	←	For Socket 8P
12	422	Machine screw with spring washer	4	J1AP2-5001010	←	←	←	For Connection box cover
44	425	Toothed lock washer	4	J1WH012-10050	←	←	←	For Connection box cover 230/460V Class
41	700	Name plate B	1	MR2SJC10S9A6	MR2SJC20S9A6	MR2SJC30S9A6	MR2SJC50S9A6	For standard speed
				MR2SJC10L9A6	MR2SJC20L9A6	MR2SJC30L9A6	MR2SJC50L9A6	For low speed
42	721	Name plate C	1	MR2SJC01S9A7 (125kg)	MR2SJC15S9A7 (1.5t)	MR2SJC25S9A7 (2.5t)	MR2SJC50S9A7 (5t)	For Name plate B
				MR2SJC03S9A7 (250kg)	MR2SJC20S9A7 (2t)	MR2SJC28S9A7 (2.8t)	X	
				MR2SJC05S9A7 (500kg)	X	MR2SJC30S9A7 (3t)	X	
				MR2SJC10S9A7 (1t)	X	X	X	
43	711	Warning seal EE	1	E2DPX10S9866	←	←	←	Electric shock

*1 Contactor Replacement : If the contactor MGC22302A for Lot.No.MR2A is not available, use the following (No.50).
After replacing with the following, use the following for replenishment as well.

50	1871	Electromagnetic contactor complete set ^{*3}	1	MGKP1102B	←	←	←	500V Class
				MGKP1102C	←	←	←	

*3 With Electromagnetic contactor, Attachment spacer, Machine screw and Lead wire.

*2 Contactor Replacement : If the contactor MGC22306B for Lot.No.MR2A is not available, use the following (No.51).
After replacing with the following, use the following for replenishment as well.

51	1871	Electromagnetic contactor complete set ^{*4}	1	MGKP1106A	←	←	←	230V/460V Class
----	------	--	---	-----------	---	---	---	-----------------

*4 With Electromagnetic contactor, Attachment spacer, Machine screw and Lead wire.

Connection box related (Dual speed inverter (VFD) type)

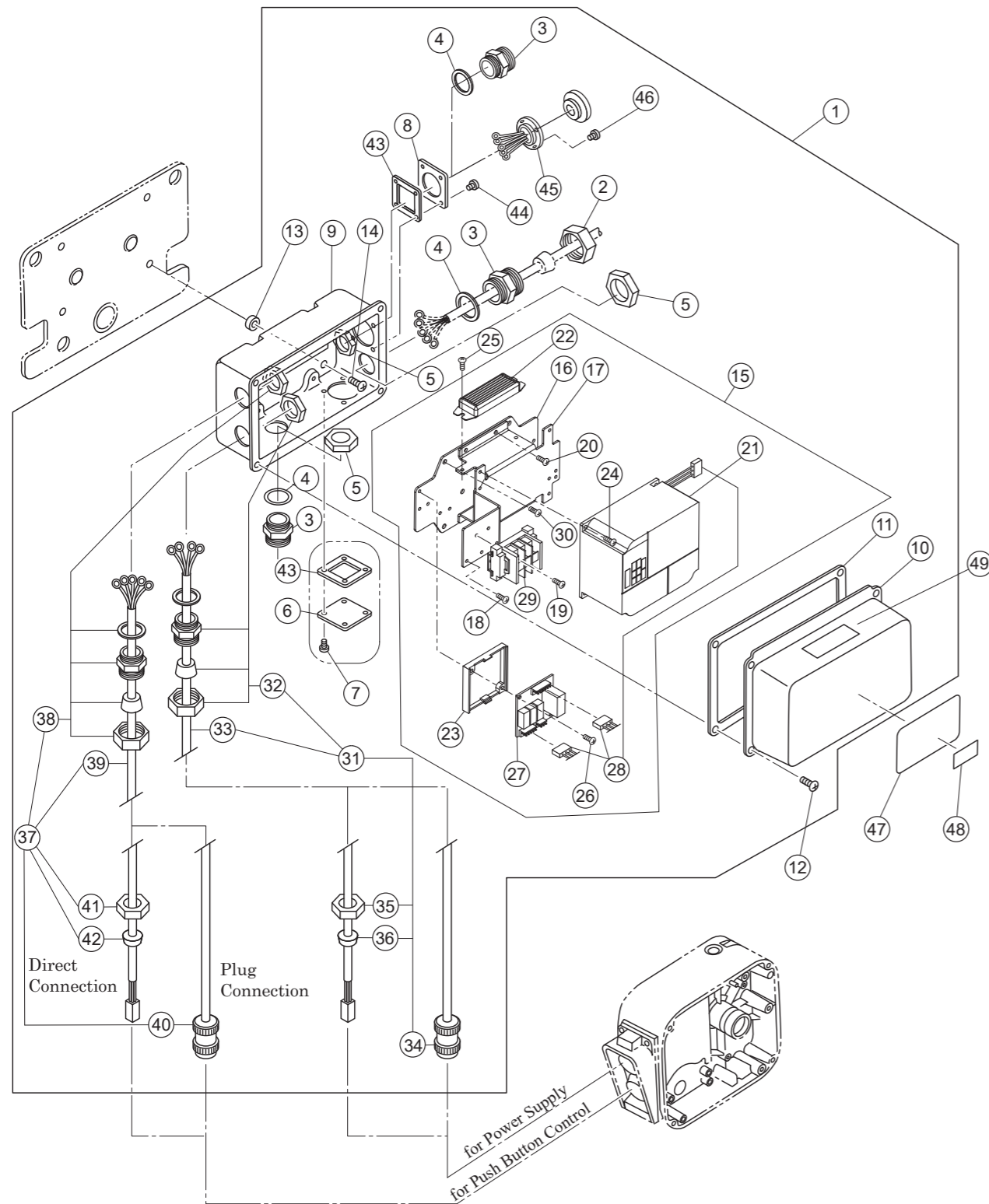

Connection box related (Dual speed inverter (VFD) type)

Figure No.	Part Number	Part Name	Quantity per unit	Product code				Remark
				MR2-010IS	MR2-020IS	MR2-030IS	MR2-050IS	
1	1401	Connection box complete set	1	MR2IJC10R1A4	MR2IJC20R1A4	←	MR2IJC50R1A4	230V Class
				MR2IJJY10R1A4	MR2IJJY20R1A4	←	MR2IJJY50R1A4	400V Class
				MR2IHE10R1A4	MR2IHE20R1A4	←	MR2IHE50R1A4	230/460V(230V) Class
				MR2IHN10R1A4	MR2IHN20R1A4	←	MR2IHN50R1A4	230/460V(460V) Class
				MR2ITC10R1A4	MR2ITC20R1A4	←	MR2ITC50R1A4	Direct connection for 230V Class
				MR2ITY10R1A4	MR2ITY20R1A4	←	MR2ITY50R1A4	Direct connection for 400V Class
2	341	Holder A	1	ECP5924AA	←	←	←	
3	342	Holder B	2/3	ECP5924AB	←	←	←	Direct connection provides 3 pieces
4	343	Packing	2/3	ECP5924AC	←	←	←	Direct connection provides 3 pieces
5	344	Holder nut	2/3	ECP5924AD	←	←	←	Direct connection provides 3 pieces
6	347	Cord cover	1	E6LE010S9630	←	←	←	
7	348	Machine screw with spring washer	4	J1AP2-5000808	←	←	←	For Cord cover
8	346	Plate P	1	ECP5924AH	←	←	←	For Plug connection
	349	Plate D		ECP5924AF	←	←	←	For Direct connection
9	401	Connection box	1	MR1DS9401	←	←	←	
10	411	Connection box cover	1	MR1DS9411	←	←	←	
11	421	Connection box packing	1	MR1DS9421	←	←	←	
13	423	Spacer	4	M6SE010S9517	←	←	←	
14	424	Machine screw with spring washer	4	J1AP2-8002020	←	←	←	For Connection box assemble
15	1445	Plate complete set	1	MR2IJC10R1A5	←	←	MR2IJC50R1A5	230V Class
				MR2IJJY10R1A5	←	←	MR2IJJY50R1A5	400V Class
				MR2IHE10R1A5	←	←	MR2IHE50R1A5	230/460V(230V) Class
				MR2IHN10R1A5	←	←	MR2IHN50R1A5	230/460V(460V) Class
				MR2ITC10R1A5	←	←	MR2ITC50R1A5	230V Class Direct connection
				MR2ITY10R1A5	←	←	MR2ITY50R1A5	400V Class Direct connection
16	441	Plate	1	MR2DI9441	←	←	←	
17	443	Plate B	1	MR2DI9443	←	←	←	
18	451	Machine screw with spring washer	3	J1AP2-4000808	←	←	←	For earth
19	452	Machine screw with spring washer	2	J1AW2-4000808	←	←	←	For Terminal
20	467	Machine screw with spring washer	4	J1AP2-4000808	←	←	←	For plate B
21	1571	VFD assembly	1	INV604C31	←	←	INV60FC31	230V Class
				INV604Y31	←	←	INV60FY31	400V Class
				INV604H31	←	←	INV60FH31	230/460V(230V) Class
				INV604M31	←	←	INV60FM31	230/460V(460V) Class
22	573	Braking resistor	1	INV904E34	←	←	INV90FE34	230V Class
				INV904Y34	←	←	INV90FY34	400V Class
23	575	Board support	1	ECP99BKAB	←	←	←	
24	580	Machine screw with spring washer	2/4	J1AP2-4001010	←	←	←	For VFD, 2 pieces for 200V and 4 pieces for 400V
25	581	Machine screw with spring washer	2	J1AW2-4000808	←	←	←	For Braking resistor
26	582	Machine screw with spring washer	2	J1AP2-4001616	←	←	←	For Interface board and Board support
27	716	Interface board	1	ECP91KB11	←	←	←	
28	863	VFD lead wire	1set	MR2IEE10R9A5	←	←	←	230V Class
				MR2IJJY10R9A5	←	←	←	400V Class
				MR2IHE10R9A5	←	←	←	230/460V Class
				MR2ITC10R9A5	←	←	←	For Direct connection
29	853	Terminal 3P	1	ECP1403AA	←	←	←	
30	454	Machine screw with spring washer	4	J1AP2-5001010	←	←	←	For Plate complete set
31	1751	Relay cable P assembly	1	MR2DS1751	MR2ES1751	←	←	For Power supply
				MR2DS1759	MR2ES1759	←	←	230/460V Class
				MR2DS2751	MR2ES2751	←	←	For Direct connection

Connection box related (Dual speed inverter (VFD) type)

Figure No.	Part Number	Part Name	Quantity per unit	Product code				Remark	
				MR2-010IS	MR2-020IS	MR2-030IS	MR2-050IS		
32	1602	Holder assembly	1	ECP5924BA	ECP5924BB	←	←		
				ECP5924BA	ECP5924BC	←	←	230/460V Class	
33	751	Cable	1	Z2CU401-0000	Z2CU402-0000	←	←		
				ZDCC401-0000	ZDCC402-0000	←	←	230/460V Class	
34	752	Plug 4P	1	ECP2304AD	ECP2304AE	←	←		
				ECP2304AD	ECP2304AF	←	←	230/460V Class	
35	341	Holder A	1	ECP5924AA	←	←	←	For Direct connection	
36	351	Cable packing	1	ECP6912AA	ECP6914AA	←	←	←	For Direct connection
37	1761	Relay cable S assembly	1	MR2DI1761	MR2E11761	←	←	←	For Operation
				MR2DI1768	MR2E11768	←	←	←	230/460V Class
				MR2DI2761	MR2E12761	←	←	←	For Direct connection
38	1602	Holder assembly	1	ECP5924BB	←	←	←		
				ECP5924BC	←	←	←	230/460V Class	
39	761	Cable	1	Z2CR601-0000	←	←	←		
				ZDCK601-0000	←	←	←	230/460V Class	
40	762	Plug 8P	1	ECP2108AB	←	←	←		
				ECP2108AC	←	←	←	230/460V Class	
41	341	Holder A	1	ECP5924AA	←	←	←	For Direct connection	
42	351	Cable packing	1	ECP6914AA	←	←	←	For Direct connection	
43	818	Cord cover packing	2	M7SE010S9527	←	←	←		
44	820	Machine screw with spring washer	4	J1AP2-5001010	←	←	←	For Plate P, D	
45	5811	Socket 8P assembly	1	MR2DI5811	←	←	←	230V, 230/460V(230V) Class	
				MR2DI6811	←	←	←	400V, 230/460V(460V) Class	
46	814	Flat head machine screw	4	J1ALP2-4001212	←	←	←	For Socket 8P	
12	422	Machine screw with spring washer	4	J1AP2-5001010	←	←	←	For Connection box cover	
47	700	Name plate B	1	MR2SJC10I9A6	MR2SJC20I9A6	MR2SJC30I9A6	MR2SJC50I9A6	For standard speed	
48	721	Name plate C	1	MR2SJC01S9A7 (125kg)	MR2SJC15S9A7 (1.5t)	MR2SJC25S9A7 (2.5t)	MR2SJC50S9A7 (5t)		
				MR2SJC03S9A7 (250kg)	MR2SJC20S9A7 (2t)	MR2SJC28S9A7 (2.8t)	X	For Name plate B	
				MR2SJC05S9A7 (500kg)	X	MR2SJC30S9A7 (3t)	X		
				MR2SJC10S9A7 (1t)	X	X	X		
49	711	Warning seal EE	1	E2DPX10S9866	←	←	←		Electric shock

Connection box related (Dual speed type, 500V Class)

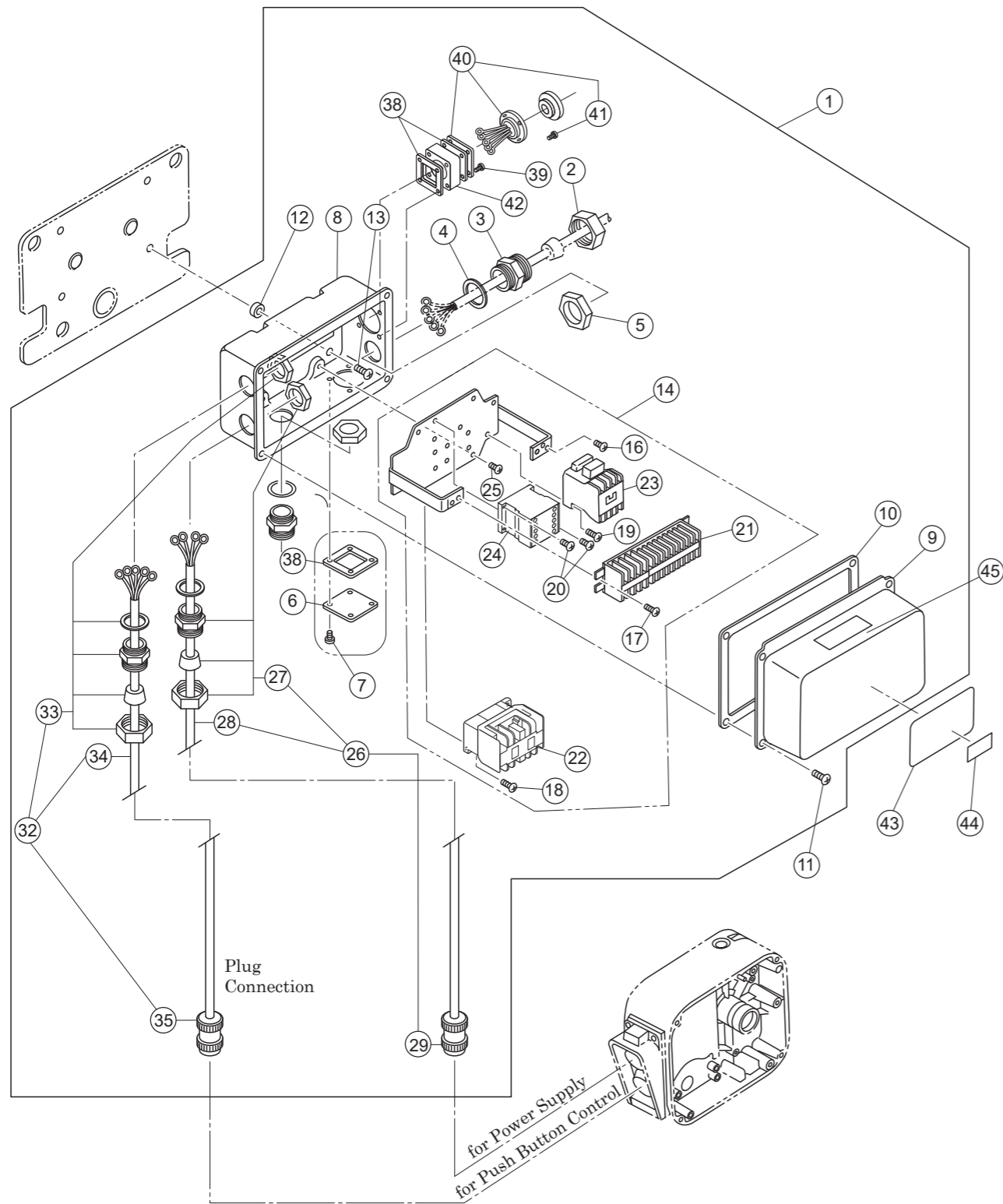

Connection box related (Dual speed type, 500V Class)

Figure No.	Part Number	Part Name	Quantity per unit	Product code				Remark
				MR2-010SD	MR2-020SD	MR2-030SD	MR2-050SD	
1	1401	Connection box complete set	1	MR2DFA10J1A4	MR2DFA20J1A4	←	←	
2	341	Holder A	1	ECP5924AA	←	←	←	
3	342	Holder B	1	ECP5924AB	←	←	←	
4	343	Packing	1	ECP5924AC	←	←	←	
5	344	Holder nut	1	ECP5924AD	←	←	←	
6	347	Cord cover	1	E6LE010S9630	←	←	←	
7	348	Machine screw with spring washer	4	J1AP2-5001010	←	←	←	For Cord cover
8	401	Connection box	1	MR1DS9401	←	←	←	
9	411	Connection box cover	1	MR1DS9411	←	←	←	
10	421	Connection box packing	1	MR1DS9421	←	←	←	
12	423	Spacer	4	M6SE010S9517	←	←	←	
13	424	Machine screw with spring washer	4	J1AP2-8002020	←	←	←	For Connection box assemble
14	1445	Plate complete set	1	MR2DFA10J1A5	←	←	←	
16	451	Machine screw with spring washer	3	J1AP2-4000808	←	←	←	For earth
17	452	Machine screw with spring washer	2	J1AW2-4001212	←	←	←	For Terminal
18	453	Machine screw with spring washer	2	J1AP2-4001616	←	←	←	For Electromagnetic contactor 871 For MGC22302A
				J1AP2-4001212	←	←	←	For Electromagnetic contactor 871 For MGC23312A
19	456	Machine screw with spring washer	2	J1AW2-4001414	←	←	←	For Electromagnetic contactor 872
20	457	Machine screw with spring washer	2	J1AP2-4001212	←	←	←	For Electromagnetic contactor 873
21	853	Terminal 16P	1	ECP1416AA	←	←	←	
22	871	Electromagnetic contactor	1	MGC22302A	←	←	←	For traveling For Lot No. MR2A *
				MGC23312A	←	←	←	For Lot No. MR2C
23	872	Electromagnetic contactor	1	MGC11222B	←	←	←	500V Class dual speed
24	873	Electromagnetic contactor	1	MGC12302A	←	←	←	For emergency stop For Lot No. MR2A
				MGC12302B	←	←	←	For Lot No. MR2C
25	454	Machine screw with spring washer	4	J1AP2-5001010	←	←	←	For plate assemble
26	1751	Relay cable P assembly	1	MR2DS1751	MR2ES1751	←	←	For Power supply
27	1602	Holder assembly	1	ECP5924BA	ECP5924BB	←	←	
28	751	Cable	1	Z2CU401-0000	Z2CU402-0000	←	←	
29	752	Plug 4P	1	ECP2304AD	ECP2304AE	←	←	For Plug connection
32	1761	Relay cable S assembly	1	MR2DS1761	MR2ES1761	←	←	For Operation
33	1602	Holder assembly	1	ECP5924BB	←	←	←	
34	761	Cable	1	Z2CR601-0000	←	←	←	
35	762	Plug 8P	1	ECP2108AB	←	←	←	For Plug connection
38	818	Cord cover packing	3	M7SE010S9527	←	←	←	
39	820	Machine screw with spring washer	4	J1AP2-5003030	←	←	←	For Socket holder
40	1811	Socket 8P assembly	1	MR2DB1811	←	←	←	
41	814	Flat head machine screw	4	J1ALP2-4001212	←	←	←	For Socket 8P assembly
42	361	Socket holder	1	ECP5924AK	←	←	←	
11	422	Machine screw with spring washer	4	J1AP2-5001010	←	←	←	For Connection box cover
43	701	Name plate B	1	MR2SJC10S9A8	←	←	←	

Connection box related (Dual speed type, 500V Class)

Figure No.	Part Number	Part Name	Quantity per unit	Product code				Remark
				MR2-010SD	MR2-020SD	MR2-030SD	MR2-050SD	
44	721	Name plate C	1	MR2SJC01S9A7 (125kg)	MR2SJC15S9A7 (1.5t)	MR2SJC25S9A7 (2.5t)	MR2SJC50S9A7 (5t)	For Name plate B
				MR2SJC03S9A7 (250kg)	MR2SJC20S9A7 (2t)	MR2SJC28S9A7 (2.8t)	X	
				MR2SJC05S9A7 (500kg)	X	MR2SJC30S9A7 (3t)	X	
				MR2SJC10S9A7 (1t)	X	X	X	
45	711	Warning seal EE	1	E2DPX10S9866	←	←	←	Electric shock

* Contactor replacement: If the contactor MGC22302A for Lot No.MR2A is not available, replace with new modified Plate complete set.
 Electromagnetic contactor complete set MGKP1102B on P6 No.50 cannot be used.
 After replacing the panel complete set, it will be the same as MR2C. For subsequent replenishment, select MR2C.

Push button related

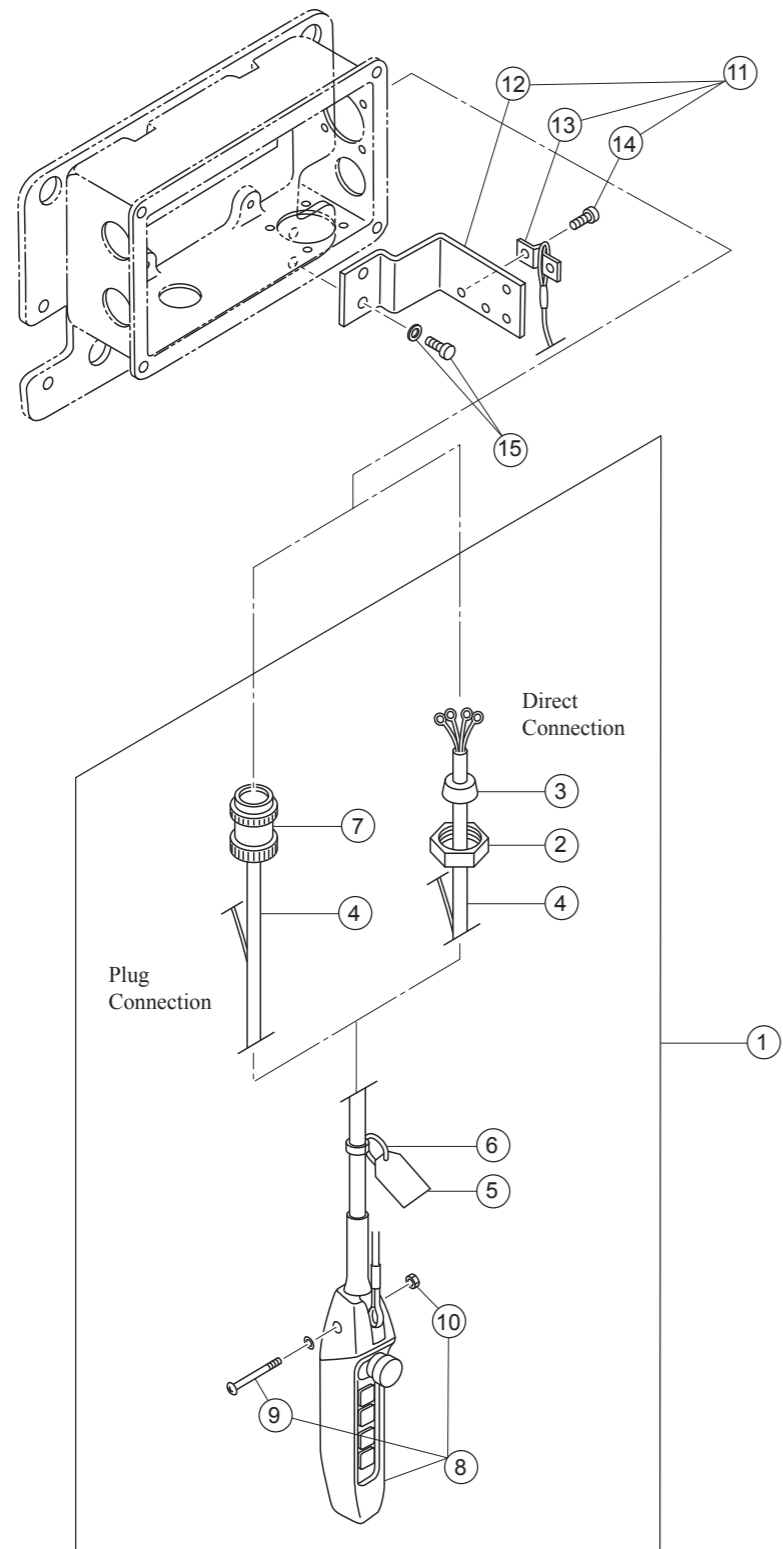

Push button related

Figure No.	Part Number	Part Name	Quantity per unit	Product code				Remark	
				ER2-Single speed MR2-Single speed	ER2-Dual speed MR2-Single speed	ER2-Single speed MR2-Dual speed	ER2-Dual speed MR2-Dual speed		
1	1781	Push button cord TR assembly	1	ZB1102AW1000	ZB2102AW1000	ZB1202AW1000	ZB2202AW1000		
				ZB1102AI5000	ZB2102AI5000	ZB1202AI5000	ZB2202AI5000	230/460V Class	
				ZBSS02AW1000	ZBDS02AW1000	ZBSD02AW1000	ZBDD02AW1000	For Direct connection	
2	341	Holder A	1	ECP5924AA	←	←	←	←	For direct connection
3	351	Cable packing	1	ECP6916AA	←	←	←	←	For direct connection
4	781	Cable	1	Z3CR701-0000	←	←	Z3CR801-0000		
				Z3CH601-0000	Z3CH801-0000	←	←	230/460V Class	
5	783	Warning tag PB	1	SWD9103AB	←	←	←		
				SWD9103AD	←	←	←	230/460V Class	
6	784	Tag holder	1	E7SE003S9787	←	←	←		
7	792	Plug 8P	1	ECP2108AC	←	←	ECP2108AD		
				ECP2108AB	ECP2108AD	←	←	230/460V Class	
8	1801	5 push button switch assembly	1	SWDB110AB	SWDB210AB	SWDB120AB	SWDB220AB		
				SWDH110AD	SWDH210AB	SWDH120AB	SWDH220AD	230/460V Class	
				SWDB110AB	SWDB210AB	SWDB120AB	SWDB220AB	For Direct connection	
9	788	Machine screw with spring washer	1	J1AP2-4002608	←	←	←		
10	789	Nut	1	J1NA004-10040	←	←	←		

Figure No.	Part Number	Part Name	Quantity per unit	Product code				Remark
				MR2-010S/L/IS/SD	MR2-020S/L/IS/SD	MR2-030S/L/IS/SD	MR2-050S/L/IS/SD	
11	1481	Bar holder assembly	1	MR1DS1481	←	←	←	
12	481	Bar holder	1	MR1DS9481	←	←	←	
13	816	Cord chain stopper	1	E6LE010S9614	←	←	←	
14	817	Machine screw with spring washer	2	J1AP2-6001212	←	←	←	For cord chain stopper
15	482	Socket bolt with spring lock washer	2	J1BG1-1002828	←	←	←	For bar holder

Power supply cable related/Accessory related/Trolley cable related

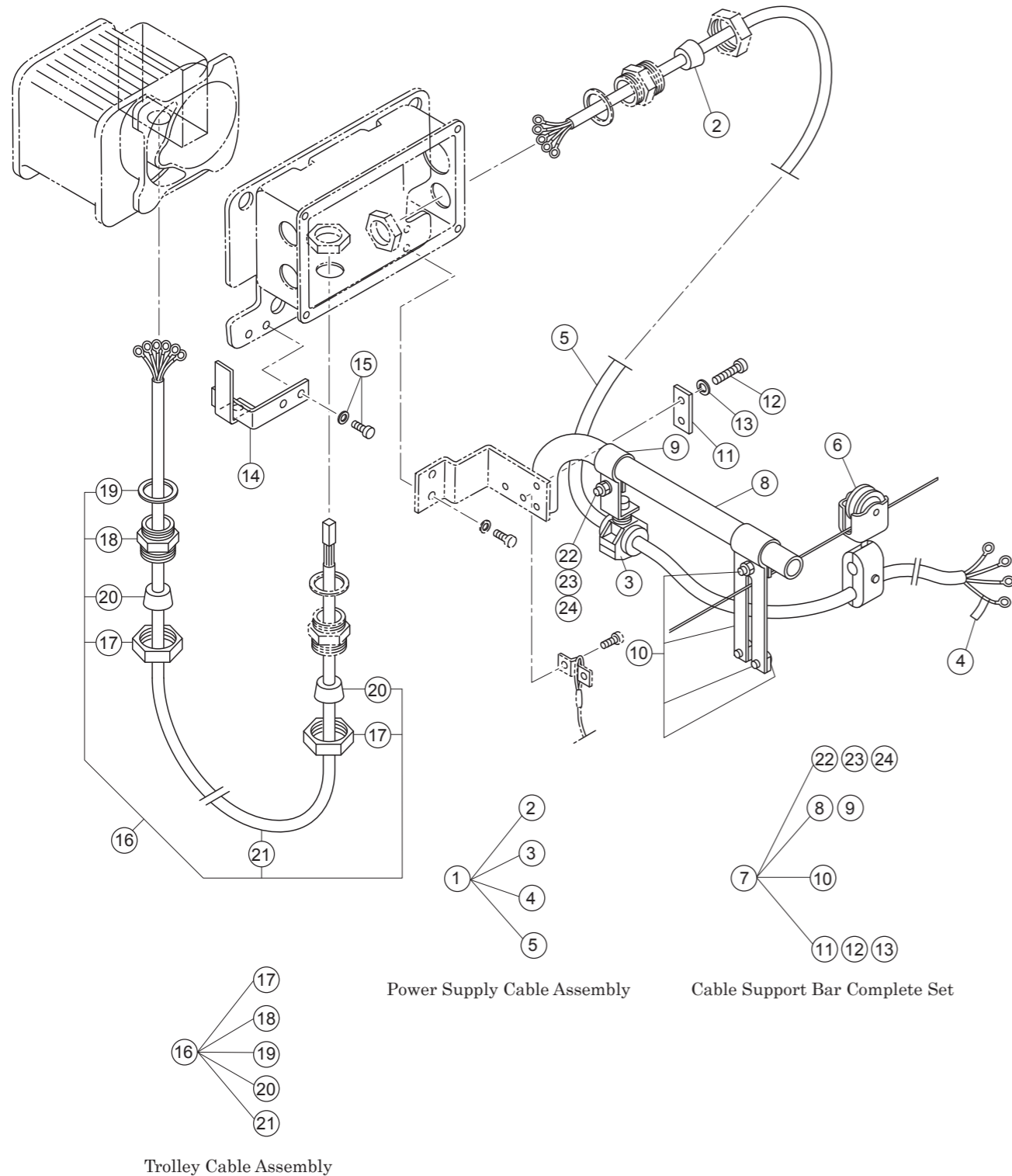

Power supply cable related/Accessory related/Trolley cable related

Power supply cable related

Figure No.	Part Number	Part Name	Quantity per unit	Product code					Remark
				MR2-010 S/L/IS/SD	MR2-020 S/L/IS/SD		MR2-030 S/L/IS/SD	MR2-050 S/L/IS/SD	
					ER2-015S/IS/SD ER2-020L/L/LD	ER2-020S/IS/SD			
1	1771	Power supply cable assembly	1	ZBZC12AJ1000	←	ZBZC12BJ1000	←	←	230/460V Class
				ZBZC12AH1000	←	ZBZC12BH1000	←	←	
2	351	Cable packing	1	ECP6914AA	←	ECP6916AA	←	←	230/460V Class
				ECP6916AA	←	ECP6918AA	←	←	
3	1724	Cable support 14 assembly	1	E4YS005-2822	←	x	x	x	230/460V Class
		Cable support 16 assembly		x	x	M3ES010-1724	←	←	
		Cable support 16 assembly		M3ES010-1724	←	x	x	x	
		Cable support 19 assembly		x	x	ECP5900CA	←	←	
4	741	Name plate G	1	E6LE010S9806	←	←	←	←	
5	771	Cable	1	Z2CU402-0000	←	Z2CU403-0000	←	←	230/460V Class
				ZDCC402-0000	←	ZDCC403-0000	←	←	
6	1641	Cable hanger 14 assembly	n	E6AX003S1527	←	←	←	←	230/460V Class
		Cable hanger 15 assembly		M3YS010-1733	←	x	x	x	
		Cable hanger 17 assembly		x	x	M7NE010S1108	←	←	

Accessory related

Figure No.	Part Number	Part Name	Quantity per unit	Product code				Remark
				MR2-010S/L/IS/SD	MR2-020S/L/IS/SD	MR2-030S/L/IS/SD	MR2-050S/L/IS/SD	
7	1491	Cable support bar complete set	1	MR1DS1491	←	←	←	For power supply cable
8	491	Cable support bar	1	MR1DS9491	←	←	←	
9	492	Cable support arm	1	MR1DS9492	←	←	←	
10	1493	Wire guide assembly	1	MR1DS1493	←	←	←	
11	501	Support bar holder (plate)	1	MR1DS9501	←	←	←	
12	505	Bolt	2	J1BA2-0803030	←	←	←	For support bar holder (plate)
13	506	Spring lock washer	2	J1WS012-20080	←	←	←	For support bar holder (plate)
22	502	Bolt	1	J1BA2-0802525	←	←	←	
23	503	Spring lock washer	1	J1WS012-20080	←	←	←	
24	504	Nut	1	J1NA002-20080	←	←	←	
14	511	Cable hanger pusher	1	MR1DS9511	x	x	x	For T-type hanger (MR1t, Beam 75mm)
	512	Cable hanger pusher	1	MR1DS9512	←	←	x	For T-type hanger (MR1t-3t, Beam 100-150mm)
	511	Cable hanger pusher	1	x	MR1ES9511	←	x	For T-type hanger (MR2t- 3t, Beam 175mm)
	511	Cable hanger pusher	1	x	x	x	MR1GS9511	For T-type hanger (MR5t, Beam125-175mm)
15	516	Socket bolt with spring lock washer	2	J1BG1-1002828	←	←	←	For cable hanger pusher

Trolley cable related

Figure No.	Part Number	Part Name	Quantity per unit	Product code			Remark
				MR2-010S/L/IS MR2-020S/L/IS MR2-030S/L/IS MR2-050S/L/IS	MR2-010SD MR2-020SD MR2-030SD MR2-050SD		
16	1791	Trolley cable assembly	1	MR2DS1791	x		
				MR2DS1792	MR2DB1793	500V Class	
				MR2DS1793	x	230/460V Class	
17	341	Holder A	2	ECP5924AA	←		
18	342	Holder B	1/2	ECP5924AB	←	500V Class	dual speed provides 2 pieces
19	343	Packing	1/2	ECP5924AC	←	500V Class	dual speed provides 2 pieces
20	351	Cable packing	2	ECP6912AA	x		
				ECP6914AA	ECP6918AA	500V Class	
				ECP6916AA	x	230/460V Class	
21	791	Cable	1	Z2CU401-0000	x		
				Z2CU601-0000	ZDCC801-0000	500V Class	
				ZDCC601-0000	x	230/460V Class	

KITO

Global Website: kito.com