

ER2 Series Electric Chain Hoist (125kg to 5t)

Disassembly and Reassembly Manual

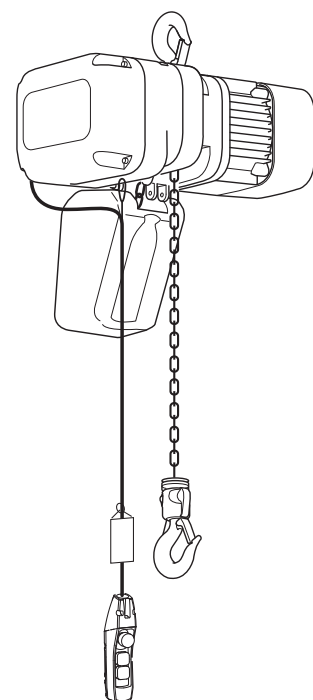

Safety precaution

This Disassembly and Reassembly Manual includes contents to prevent injury to any person performing disassembly and reassembly, users, and other persons and damage to property, and to disassemble/reassemble the electric chain hoist safely and correctly.

Before performing disassembly/reassembly, be sure to read and follow this manual as well as the ER2 Series Electric Chain Hoist Owner's Manual (separate document) since its contents are also important for disassembly/reassembly.

Disassembly/reassembly of the electric chain hoist are required operations for regular inspection and repair. Carry out disassembly/reassembly properly in accordance with these manuals.

Persons performing disassembly/reassembly

Disassembly/reassembly shall be performed by a competent person (a person duly authorized by the company as having expertise on the structure and device of the electric chain hoist) or consult KITO.

Safety precaution

Disassembly and reassembly (general)

DANGER



Prohibited

- Only competent persons must disassemble/reassemble the electric chain hoist.

Disassembly/reassembly by anyone other than competent persons may result in death or severe injury.



Prohibited

- Do not use unauthorized parts for KITO Electric Chain Hoist.

Even if the part is an authorized part, it may not be used for a different model.
Use parts correctly in accordance with this manual.

Failure to follow this instruction may result in death or severe injury.



Prohibited

- Do not disassemble/reassemble the Electric Chain Hoist subject to a load.

When disassembling/reassembling an electric chain hoist, place it on a floor and perform them on the workbench.

Failure to follow this instruction may result in death or severe injury.



Prohibited

- Do not perform disassembly/reassembly during conduction.

Failure to follow this instruction may result in death or severe injury due to an electric shock or unexpected operation.



Prohibited

- Do not adjust or disassemble the friction clutch and friction clutch with mechanical brake.

Failure to follow this instruction may result in death or severe injury.
If adjustment and disassembly are required, contact Kito.



Prohibited

- Do not use gear oil or grease in areas near a fire or spark.

Failure to follow this instruction may result in fire or severe injury arising from ignition.



Prohibited

- Do not cut, extend, or weld the load chain.

Failure to follow this instruction may result in death or severe injury.



Mandatory

- Carry out the installation or removal work after securing the stable foothold.

Failure to follow this instruction may result in death or severe injury due to falling or dropping.



Mandatory

- Carry out the installation or removal work of the electric chain hoist after shutting down the power distribution panel.

Failure to follow this instruction may result in death or severe injury due to an electric shock.



Mandatory

- When reassembly is complete, perform a function check (preoperational check) to make sure it operates properly.

Failure to follow this instruction may result in death or severe injury.
For details, refer to 'Periodic Inspection' in the separated Owner's Manual.



Mandatory

- Tighten the bolts and nuts with the specified tightening torques.

Failure to follow this instruction may result in death or severe injury.

! CAUTION



Mandatory

- **When reassembling, follow the instructions below.**
 - Before reassembly, remove dust and oil on the part to be reused.
 - Insert snap rings completely in the groove.
 - Assemble the load chain without torsion.
 - When setting the plate in the gear case, be careful so that your finger won't get caught.

Failure to follow these instructions may cause bodily injury or loss of property arising from damaged product or dropped parts.



Mandatory

- **When reassembling, replace the following parts with new ones.**
 - Gear oil (type and required amount of oil vary depending on the specification and main body size. Refer to page 48.)
 - Packing
 - Molybdenum disulfide lubricant Molytherm No.2: (specified brand: SUMICO LUBRICANT)
 - Oil seal
 - Snap ring
 - Split pin
 - O ring

Failure to follow this instruction may cause bodily injury or loss of property.

Before disassembly and reassembly

! DANGER



Mandatory

- **Only competent persons with expertise and experience must disassemble/reassemble the electric chain hoist. Alternately, contact the nearest distributor or KITO.**

Disassembling/reassembling improperly causes death or severe injury.

- Perform disassembly and reassembly in correct procedures as described in the manual.
- Do not extend the load chain.
- Before reassembling the parts such as gear, clean and remove oil and dust on them. Especially when a plastic hammer is used, clean them thoroughly so that no chip of the hammer remains inside.
- Prepare anti-loosening (screw lock) for bolts. Apply it to the specified locations.
- Use only authorized parts for replacement.

Failure to follow these instructions may result in death or severe injury.

NOTE

The disassembly and reassembly procedures are described based on the representative model. Note that components may be slightly different for different capacities.







The specifications may be changed without prior notice and may be different from the actual products.

Table of Contents

Safety precaution	2
Table of Contents	4
Disassembly and assembly tool	5
Name of parts	6
Disassembly procedure	8
1 Removing the outer circumference parts	8
2 Removing the controller cover	9
3 Removing the top hook	14
4 Disassembling the gear parts	15
5 Disassembling the load chain circumference	18
6 Disassembling the motor and electromagnetic brake	19
7 Disassembling the body part	22
Reassembly procedure	24
1 Assembling the body	24
2 Assembling the motor and electromagnetic brake	27
3 Connecting the motor and body	31
4 Installing the load chain	32
5 Assembling the gear parts	34
6 Installing the top hook	37
7 Assembling the controller cover	39
8 Installing the bottom hook (if removed from the chain)	46
9 Oil filling	48
10 Operation check, etc.	49

Disassembly and assembly tools

For disassembly and reassembly, prepare the following tools.

No.	Tool name	Application	Icon
1	Wrench 10mm / 13mm / 17mm / 19mm	Bolts and nuts	
2	Hexagon wrench 4mm / 5mm / 6mm / 8mm / 10mm	Socket bolts	
3	Snap ring pliers S (Large) (Small)	Snap rings (shaft)	
4	Snap ring pliers R	Snap rings (hole)	
5	Socket wrench 10mm	Bottom yokes	
6	Combination pliers	Split pins	
7	Adjustable wrench		
8	Plastic hammer		
9	Screwdrivers (+)(-)		
10	Puller	Bearing, fan, brake, hub	
11	Thickness gauge		
12	Torque wrench/nut runner		
13	Plier	Set pin	

- Use the following types of grease.

- JIS K2220 Grease type 1 No.2 for Roller shaft bearing
- Molybdenum disulfide lubricant Molytherm No.2 (Specified brand: SUMICO LUBRICANT)

- Helpful tools

- Remover: Prepare a remover for bearings (for inner race & outer race) and one for oil seal for precise operation.
- Preparing two wooden blocks (used as sleepers) and wire for guiding lead wires will be helpful.

Name of parts

The structure and names of parts in the controller cover are shown on the next page for each model.

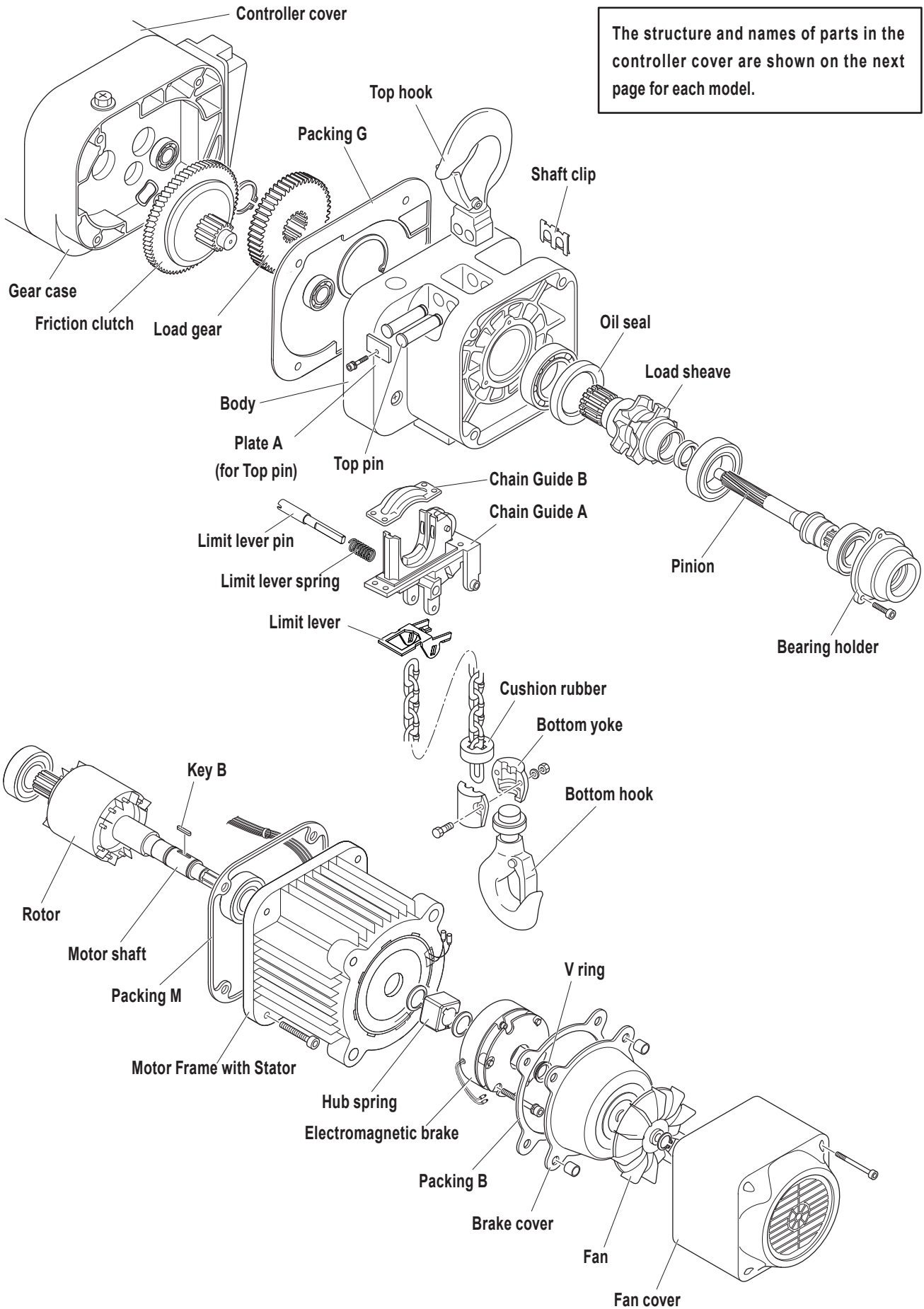

■ Single speed type / Dual speed pole change type

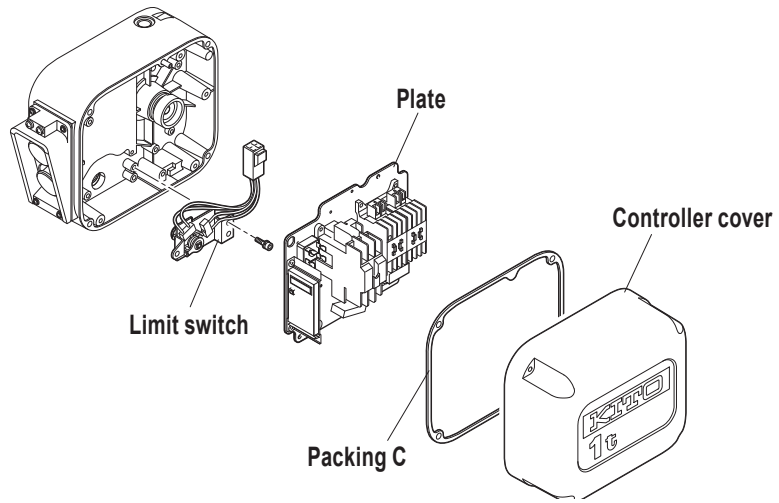

■ Dual speed inverter type (Basic main body B/C type)

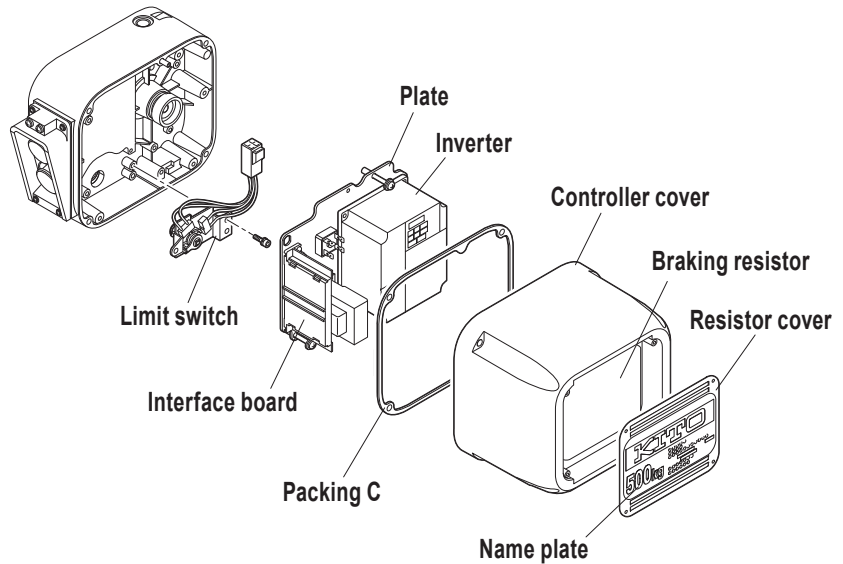

■ Dual speed inverter type (Basic main body D/E/F type)

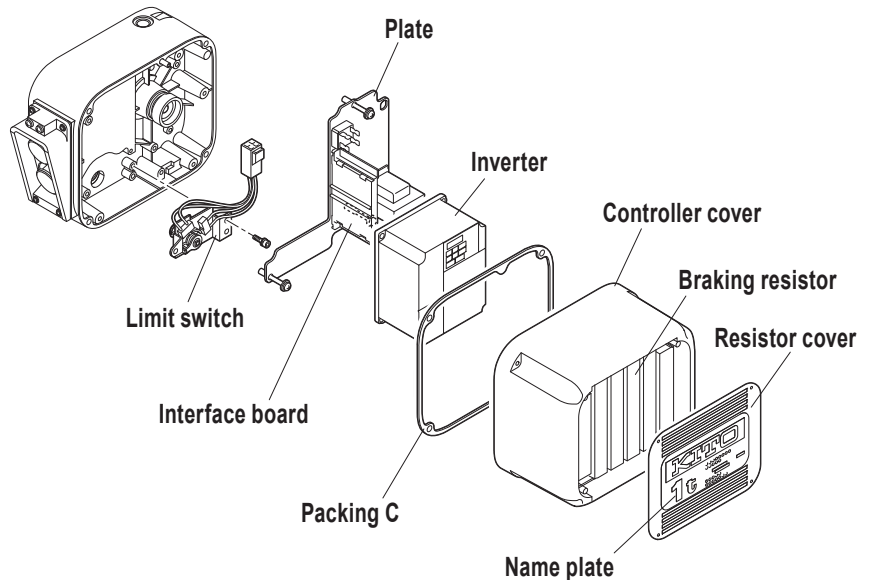

Disassembly procedure



DANGER



Prohibited

- Do not disassemble the electric chain hoist while it is being suspended.

Failure to follow this instruction may result in death or severe injury due to dropped parts.

Be sure to place the electric chain hoist on a floor and perform the disassembly on the workbench.

The overall disassembly procedure is shown below. Perform disassembly of only necessary parts.

1 Removing the outer circumference parts

<Plug connection>

- (1) Remove the protection wire from the main body, and remove the push button cord complete set with plug 8P.
- (2) Remove the power supply cable assembly with plug 4P and cable support arm from the main body.

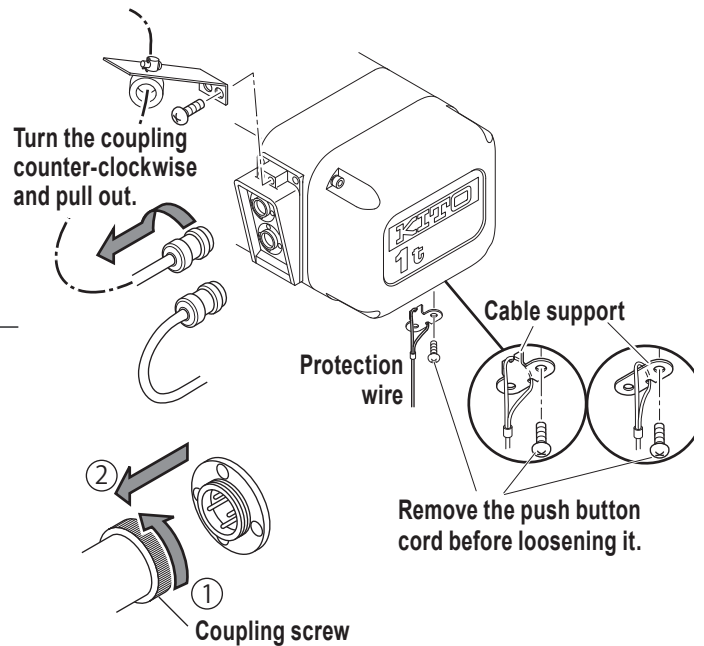

<Direct connection>

- (1) Turn Holder A and remove it from Holder C.
 - Do not pull the cable at this time, as it is still attached to the inside of the main body.
 - Remove the controller cover, disconnect the connector to which the cable is connected, and then pull the cable out.

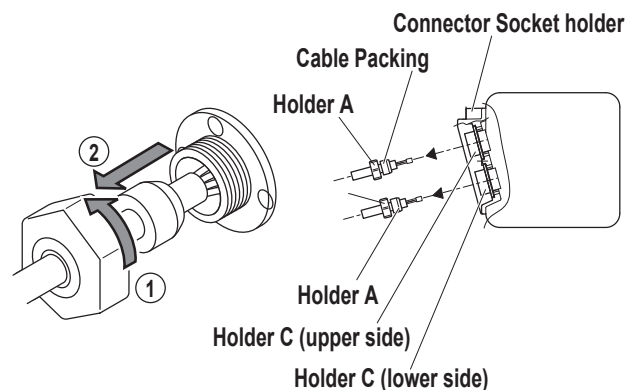

- (2) Remove the chain container from the main body.

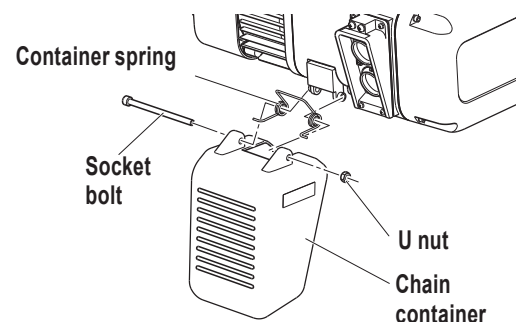

- (3) When disassembling the gear part, remove the oil plug (for waste oil hole) and plug packing from the bottom of the gear case, and then remove gear oil.

- Check stain and viscosity of the removed oil.
- If any metal powder is discovered, perform a careful inspection suspecting abnormal wear of the gear or clutch.

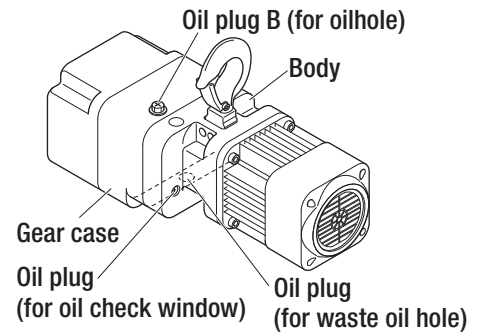

2 Removing the controller cover

Single speed type / Dual speed pole change type

CAUTION



Mandatory

- When opening the controller cover, support it with your hand and open it slowly and carefully. Failure to follow this instruction may cause the controller cover to hit the internal electrical components, resulting in damage.

- (1) Loosen the 4 socket bolts and open the controller cover.
- If it is difficult to open, hammer the cover side gently with a plastic hammer, as shown to the right.

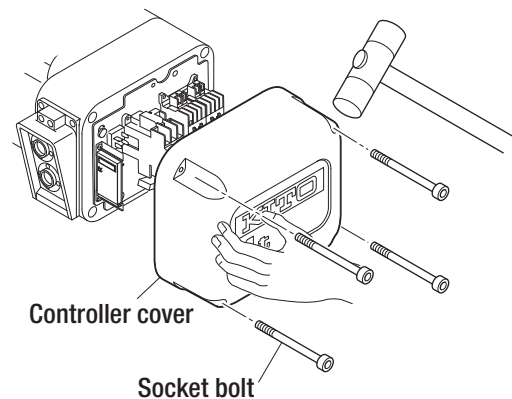

- (2) Remove the socket bolt (gear case side) securing the cover belt, and remove the controller cover from the gear case.

- The controller cover can be removed with the cover belt attached.

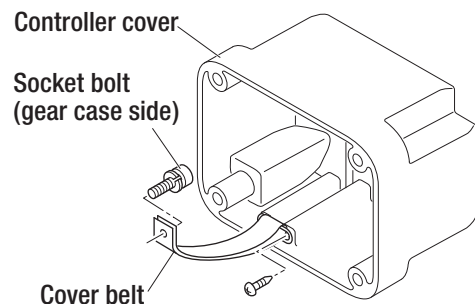

- (3) Remove the lead wire and connector between the panel plate and main body, and remove the panel plate.

- Loosen the 3 setscrews, and turn the panel plate a little according to the shape of the fulcrum pin to remove it.
- Make a note of the locations of the lead wire connections that will be referred to upon reassembly.

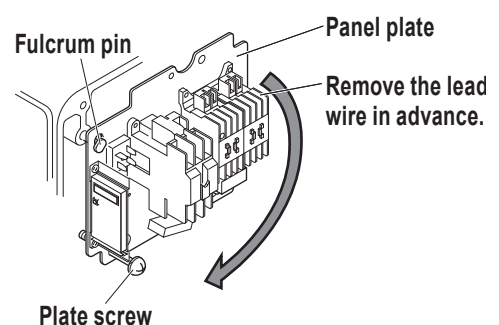

- (4) Remove the limit switch as required.
- Remove 4 lead wires (connectors) of the limit switch first.
 - Loosen the 3 socket bolts to remove the limit switch (replace the O ring attached to the shaft with a new part upon reassembly).
 - Be careful when removing the limit switch because it may be damaged if handled in a wrong way.

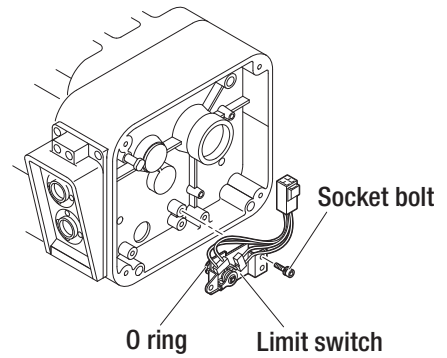

! DANGER

Prohibited

- Do not disassemble the limit switch.

Replace the limit switch as an assembly. Disassembly causes a defective operation, and a major accident may occur.

■ Dual speed inverter type (Basic main body B/C type)

! CAUTION

Mandatory

- When opening the controller cover, support it with your hand and open it slowly and carefully. Failure to follow this instruction may cause the controller cover to hit the internal electrical components, resulting in damage.
- The controller cover is very hot immediately after operation. Wait until about 30 minutes after operation.

- (1) Loosen the 4 socket bolts and open the controller cover.
- If it is difficult to open, hit the cover side gently with a plastic hammer, as shown to the right.

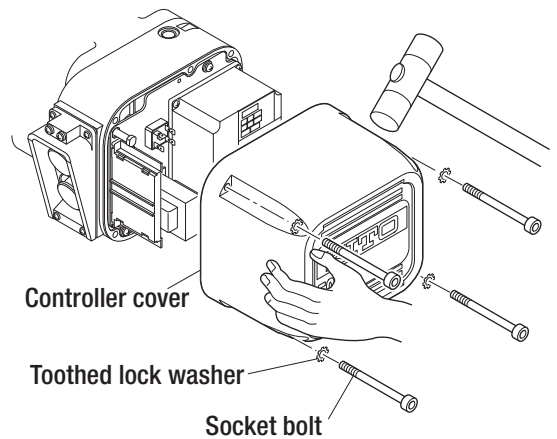

- (2) Remove the connector and ground line connected to the controller cover.

- To remove the ground line, loosen the pan-head machine screw of the plate side.

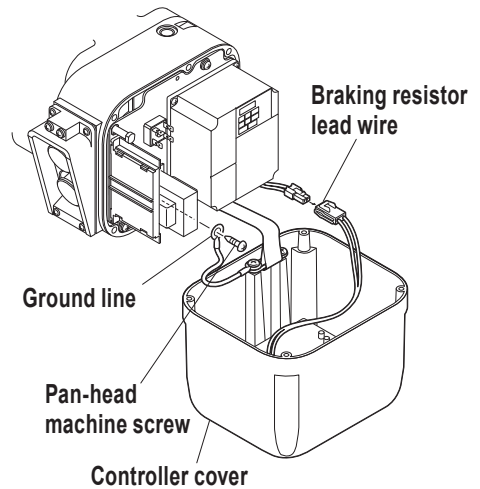

- (3) Remove the socket bolt (gear case side) securing the cover belt, and remove the controller cover from the gear case.

- The controller cover can be removed with the cover belt attached.

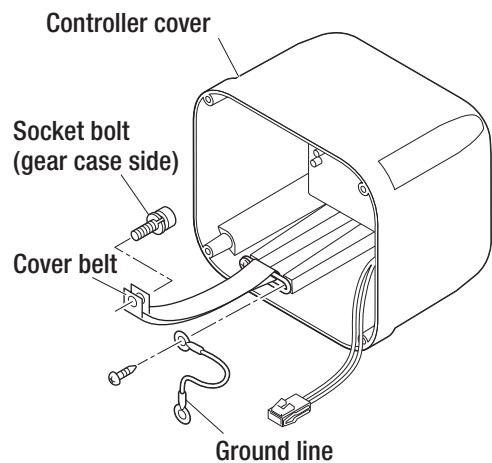

- (4) Remove the lead wire and connector between the plate, main body, and inverter, and remove the plate.

- Loosen the 3 Plate screws, and turn the plate a little according to the shape of the fulcrum pin to remove it.
- Make a note of the locations of the lead wire connections that will be referred to upon reassembly.

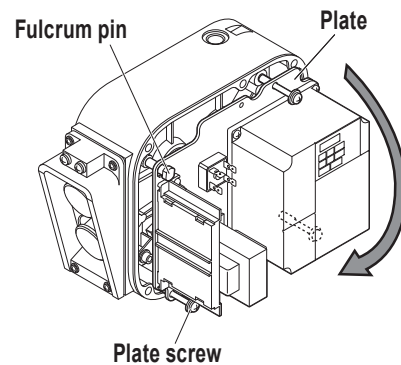

- (5) Remove the limit switch as required.
- Remove the connector of the limit switch first.
 - Remove it carefully by holding the connector of the limit switch side.
 - Loosen the 3 socket bolts to remove the limit switch (replace the O ring attached to the shaft with a new part upon reassembly).
 - Be careful when removing the limit switch because it may be damaged if handled in a wrong way.

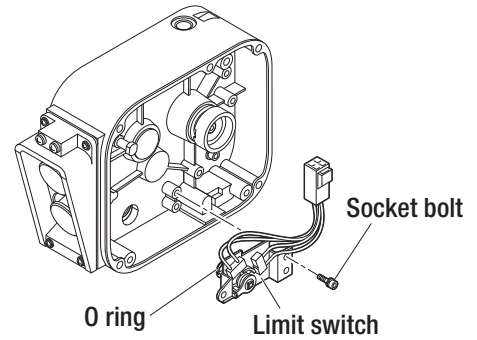

! DANGER

Prohibited

- Do not disassemble the limit switch.

Replace the limit switch as an assembly. Disassembly causes a defective operation, and a major accident may occur.

Dual speed inverter type (Basic main body D/E/F type)

! CAUTION

Mandatory

- When opening the controller cover, support it with your hand and open it slowly and carefully. Failure to follow this instruction may cause the controller cover to hit the internal electrical components, resulting in damage.
- The controller cover is very hot immediately after operation. Wait until about 30 minutes after operation.

- (1) Loosen the 4 socket bolts and open the controller cover.
- If it is difficult to open, hit the cover side gently with a plastic hammer, as shown to the right.

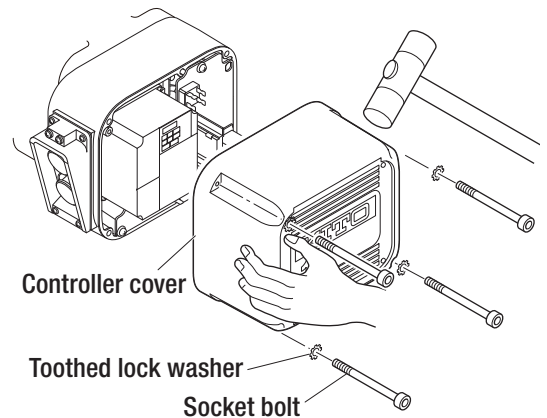

- (2) Remove the connector and ground line connected to the controller cover.

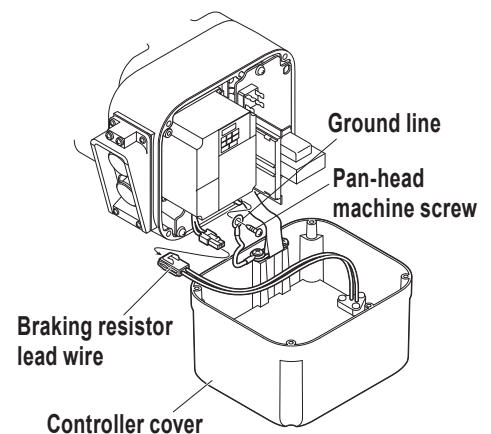

- (3) Remove the socket bolt (gear case side) securing the cover belt, and remove the controller cover from the gear case.

- The controller cover can be removed with the cover belt attached.

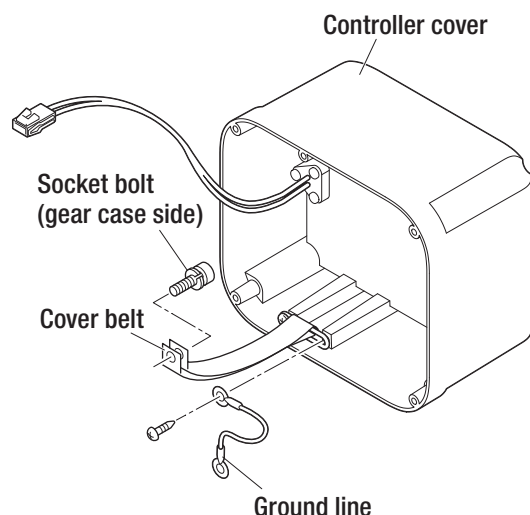

- (4) Remove the lead wire and connector between the plate, main body, and inverter, and remove the plate and inverter.

- Loosen the 3 Plate screws to remove the plate.
- Loosen the 4 pan-head machine screws of the inverter to remove it.
- Make a note of the locations of the lead wire connections that will be referred to upon reassembly.

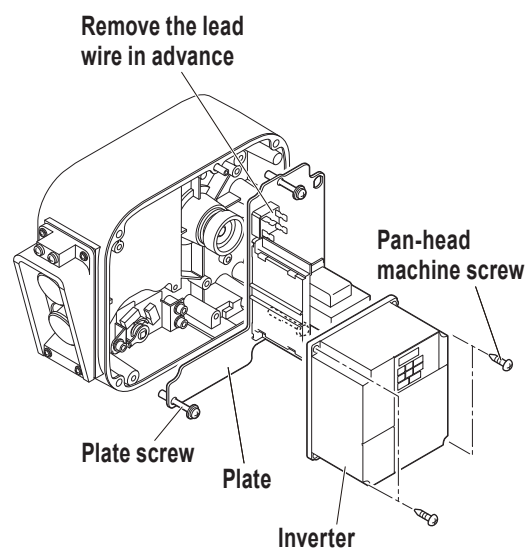

- (5) Remove the limit switch as required.

- Remove the connector of the limit switch first.
- Remove it carefully by holding the connector of the limit switch side.
- Loosen the 3 socket bolts to remove the limit switch (replace the O ring attached to the shaft with a new part upon reassembly).
- Be careful when removing the limit switch because it may be damaged if handled in a wrong way.

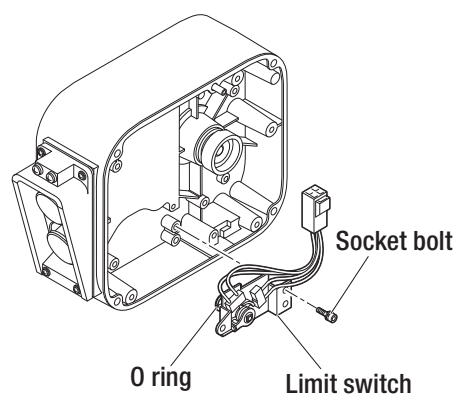

DANGER



Prohibited

- Do not disassemble the limit switch.

Replace the limit switch as an assembly. Disassembly causes a defective operation, and a major accident may occur.

3 Removing the top hook

Remove the top hook first to make it easier to disassemble other parts.

- Removing the top hook (Basic main bodies B, C, D, and E)

(1) Loosen the socket bolt to remove the Plate A (for Top pin).

(2) Remove the shaft clip in the opposite side.

- Pull up the shaft clip to remove.
- If it is difficult to remove, use the longnose pliers to open the presser part and slide it upward.

(3) Remove the top pin, and then top hook.

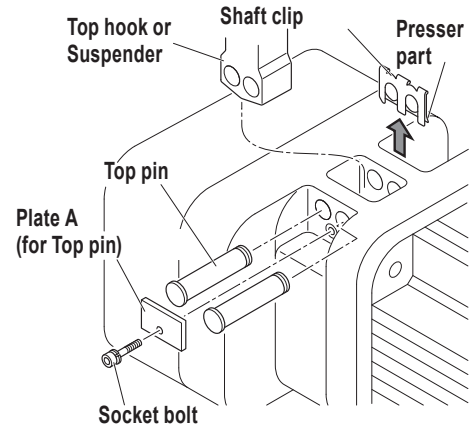

- Removing the top hook (Basic main body F)

- For the double chain type, remove the load chain first.
 1. Pull out the split pin securing the slotted nut of the chain pin, and remove the slotted nut.
 2. Loosen the chain pin to remove the load chain.

1. Loosen the 2 socket bolts to remove the Plate A (for Top pin).
2. Loosen the 2 pan-head machine screws to remove the Plate A (for fixing shaft).
3. Pull out Top pin and Fixing shaft.
 - If it is difficult to pull out smoothly, remove Stator on the opposite side, remove Shaft plug, and use a proper jig to pull out Top pin, hammering with a Plastic hammer.
 - For disassembly of the stator, refer to page 19.
4. Remove the 2 O rings each from the top pin and Fixing shaft.
5. Remove the hook or Connection yoke.

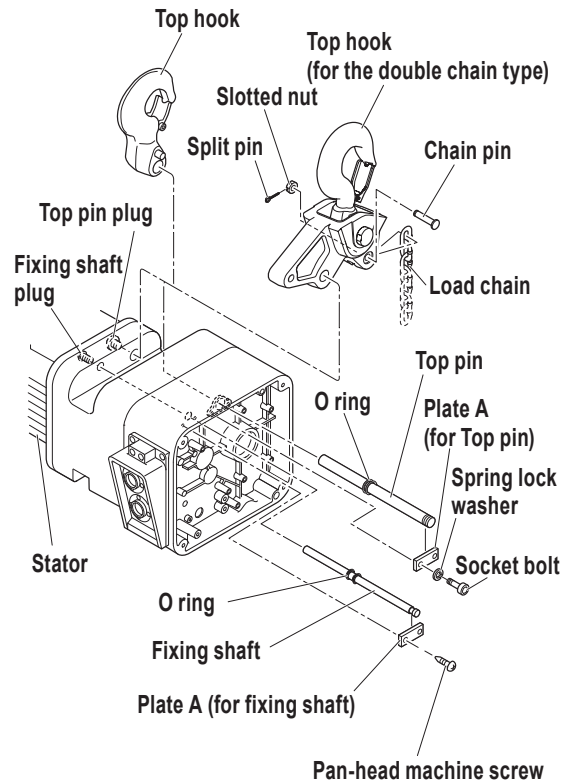

4 Disassembling the gear parts

(1) Remove the friction plug from the gear case as required.

- For the friction clutch with mechanical brake ("friction clutch with mechanical brake" hereafter) specification, this operation is not required.

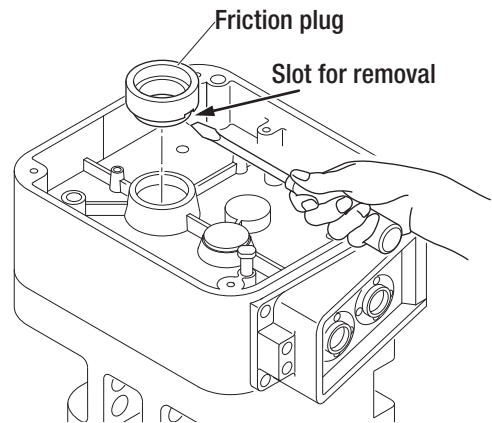

(2) Loosen the 4 socket bolts (5 for F type). Hammer the gear case gently with a plastic hammer to remove it.

- Remove it carefully not to pull the lead wire from the motor or brake.
- Note that the gear case may come off with the friction clutch attached to it.

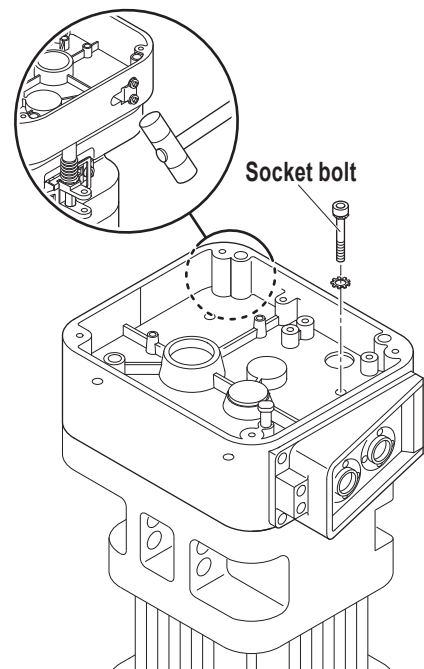

(3) Remove Packing G and set pin.

- Be careful not to scratch the gear case junction face.
- For Friction clutch with mechanical brake specification, remove Spacer M.

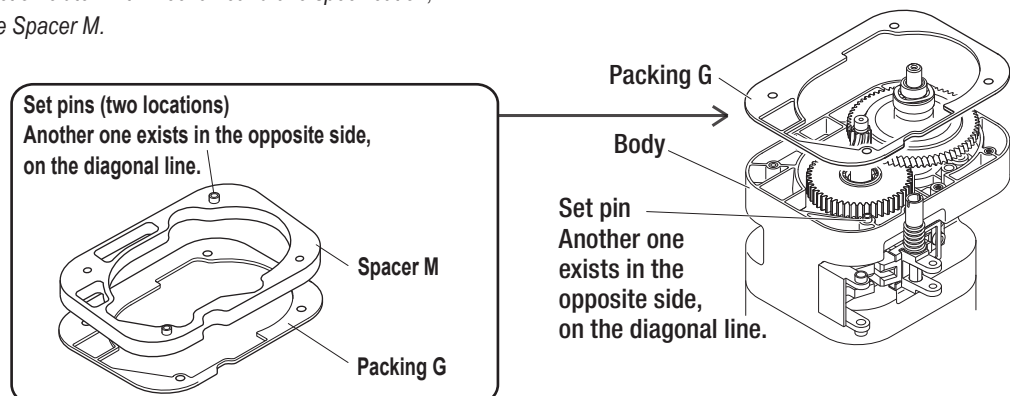

DANGER



- Do not disassemble the friction clutch or friction clutch with mechanical brake.

Failure to follow this instruction may result in death or severe injury due to a falling load.

Prohibited

- Double reduction
 - The gear configuration as shown to the right is the double reduction specification. Perform disassembly in the following steps.

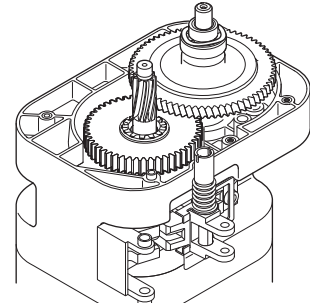

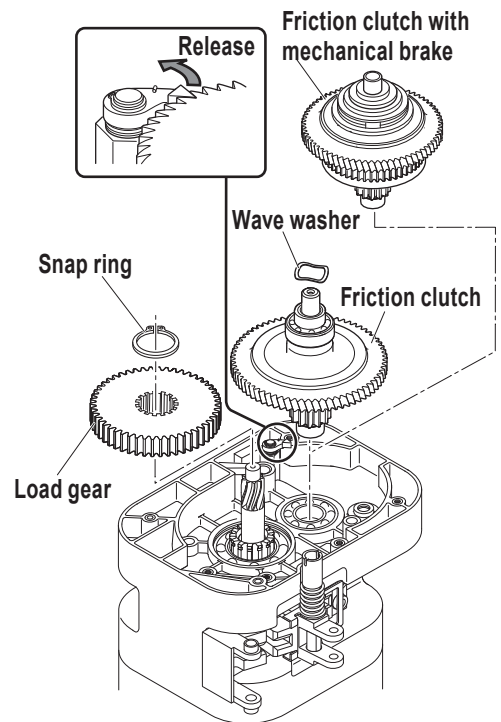

- (4) Remove the wave washer and friction clutch from the body.
- For the friction clutch with mechanical brake specification, release the pawl from the ratchet disc to remove the friction clutch with mechanical brake. (There is no wave washer.)



- (5) Remove the snap ring, and remove the load gear.

- Friction clutch with mechanical brake specification (option)
- (6) Remove the snap ring, and remove the pawl spring and pawl from the pawl shaft.



DANGER



- The pawl shaft is fixed to the body with pawl shaft washer and screw lock. Do not remove it.

Failure to follow this instruction may cause the pawl shaft to come off and result in death or severe injury due to a dropped load.

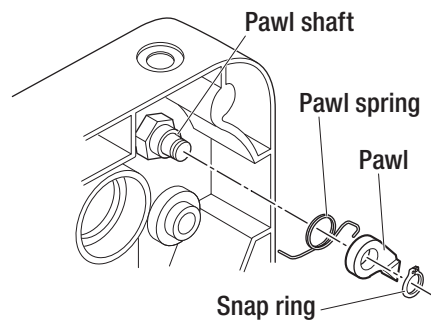
Prohibited



● Triple reduction

- The gear configuration with Gear B built in as shown to the right is the triple reduction specification. Perform disassembly in the following steps.

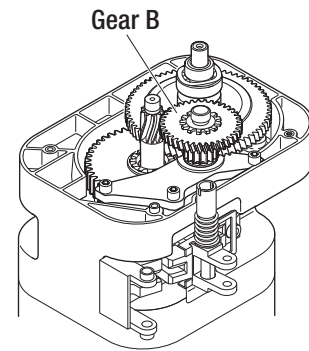

(4) Remove Gear B from the bearing of the gear plate.

(5) Remove the set spring and friction clutch from the body.

- For the friction clutch with mechanical brake specification, release the pawl from the ratchet disc to remove the friction clutch with mechanical brake. (There is no set spring.)

(6) Loosen the 3 socket bolts, and remove the gear plate from the body.

(7) Remove the snap ring, and remove the load gear.

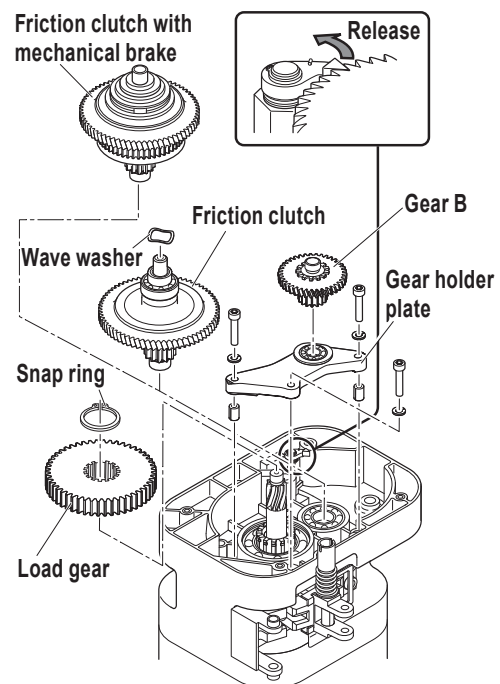

● Friction clutch with mechanical brake specification (option)

(8) Remove the snap ring, and remove the pawl spring and pawl from the pawl shaft.

! DANGER



Prohibited

- The pawl shaft is fixed to the body with pawl shaft washer and screw lock. Do not remove it.

If you do, the pawl shaft will come off, and a major accident such as death or serious injury may occur due to a dropped load.

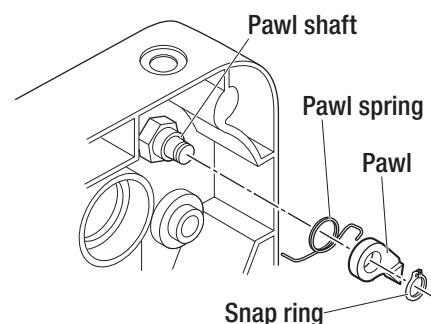

5 Disassembling the load chain circumference

- (1) Remove the stopper and cushion rubber from the load chain (no load side).
 - For the double chain type, also remove the stopper of the load side.

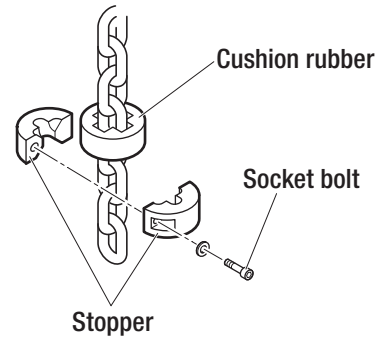

- (2) Remove the load chain from the body to the load side.
 - Remove the bottom hook as required.

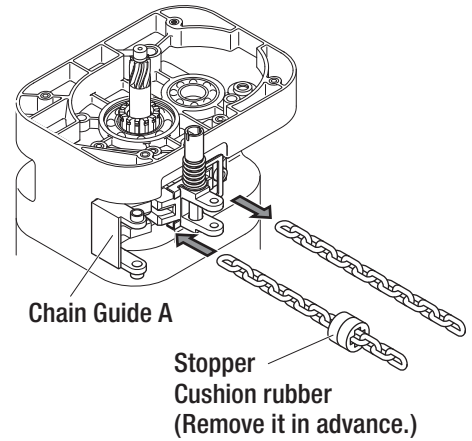

- (3) Remove the limit lever.
 - Remove the limit lever pin, limit lever spring, and then limit lever.

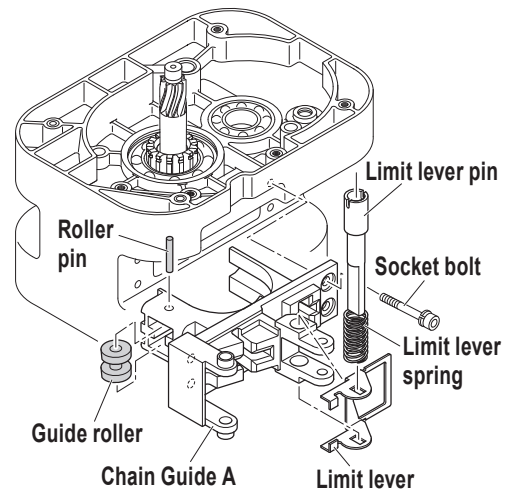

- (4) Loosen the 4 socket bolts, and remove Chain Guide A from the body.
 - Remove the guide roller and roller pin.
(Basic main bodies B and C are not provided with Guide roller.)
 - Be careful not to lose the roller pin of the guide roller during operation.

6 Disassembling the motor and electromagnetic brake

(1) Loosen the 4 socket bolts, and remove the fan cover.

- *DO NOT use impact and electric screwdriver, use a hand tool such as a hexagonal wrench, and then loosen gently.*
- *When the socket bolt is stuck in the middle of loosening, do not force it to loosen, and turn it in the opposite direction (clockwise) sometimes for loosening safely.*

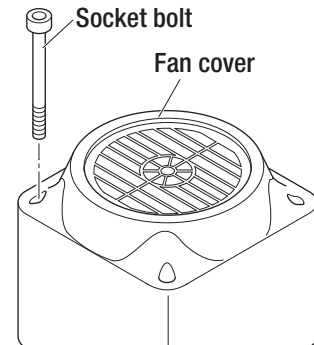

(2) Remove the snap ring.

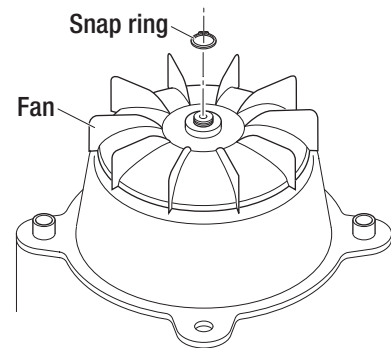

(3) Insert the "pawl" part of the puller to the outer circumference bottom of the fan to remove the fan.

- *Insert it as close to the blade as possible. Be careful not to damage the fan.*
- *Use a three-pawl puller for safer operation.*

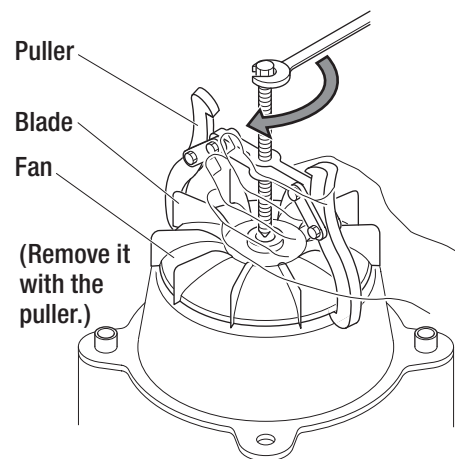

(4) Remove the set pin.

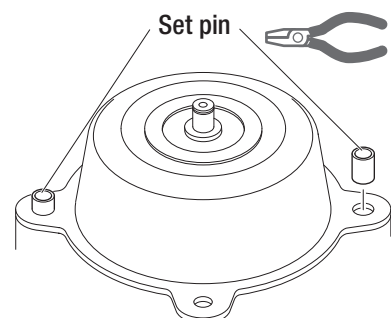

- (5) Remove the brake cover.
- If it is difficult to remove, hammer it gently with a plastic hammer to remove.
 - Be careful not to hammer it too much to cause deformation.

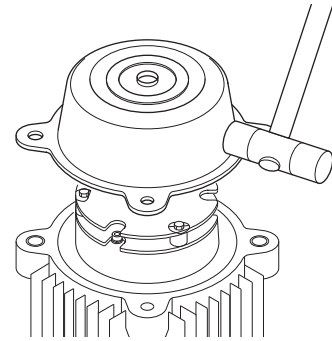

- (6) Remove the brake wiring.
- Hold the male and female bullet terminals to remove it.
 - Be careful not to pull the lead wire causing damage in the connection with the bullet terminal.

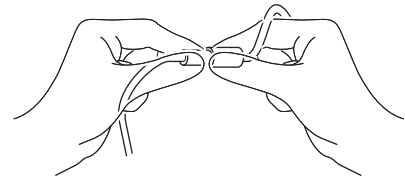

- (7) Remove the socket bolt (with spring washer), and remove the brake.
- Make a note of the installation position (lead wire position) of the electromagnetic brake for easy reassembly.

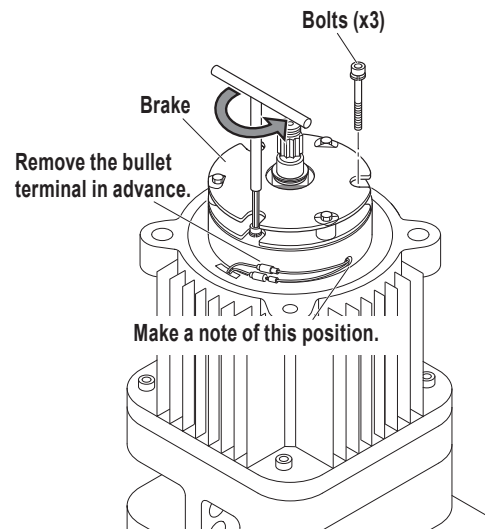

! DANGER



Prohibited

- Do not disassemble the electromagnetic brake.
- Failure to follow this instruction may cause death or sever injury due to a falling load.

- (8) Check the V ring for any abnormality.
- If the V ring is worn, check for dust entering to the brake.

(9) Remove the V ring, snap ring, Packing B, and hub.

- Be careful not to scratch the motor junction face.
- Some models don't have the snap ring (for hub bottom).
- Remove the hub using a puller.
- Spline hub is also available.

● Spline hub

- First, remove the 3 hub springs installed to the spline hub and store them.

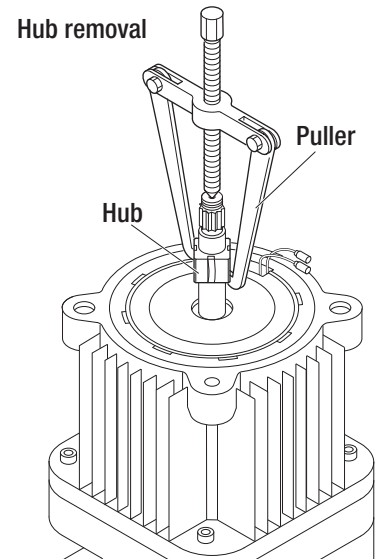
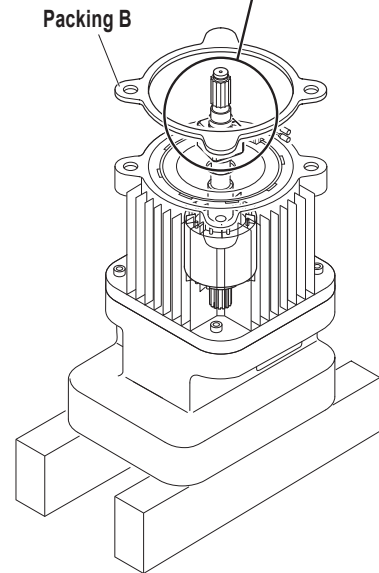
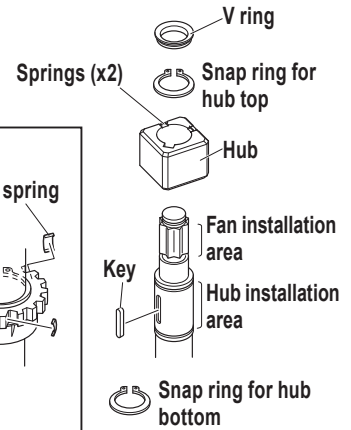
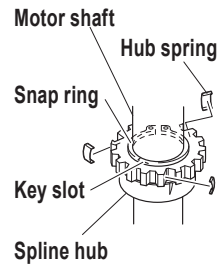

(10) Remove the 4 socket bolts. Hammer the stator gently with a plastic hammer to remove it from the body.

- Turn it over so that the stator is facing down and the body is facing up.
- Use a wooden block for easier operation.
- Handle it carefully not to damage the motor lead wire.
- DO NOT use impact and electric screwdriver, use a hand tool such as a hexagonal wrench, and then loosen gently.
- When the socket bolt is stuck in the middle of loosening, do not force it to loosen, and turn it in the opposite direction (clockwise) sometimes for loosening safely.

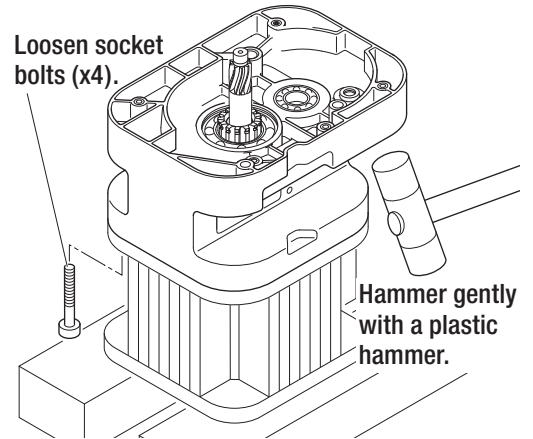

(11) Remove Packing M.

- Be careful not to scratch the motor junction face.
- Remove the set pin.

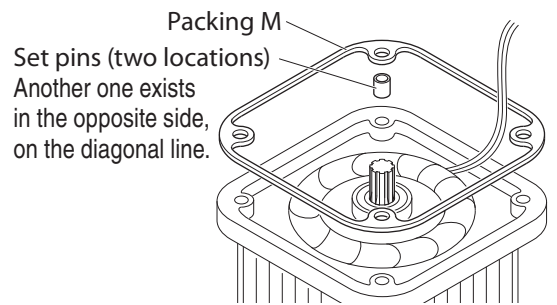

(12) Remove the rotor from the stator.

- Be careful not to scratch the stator inner circumference and rotor outer circumference.

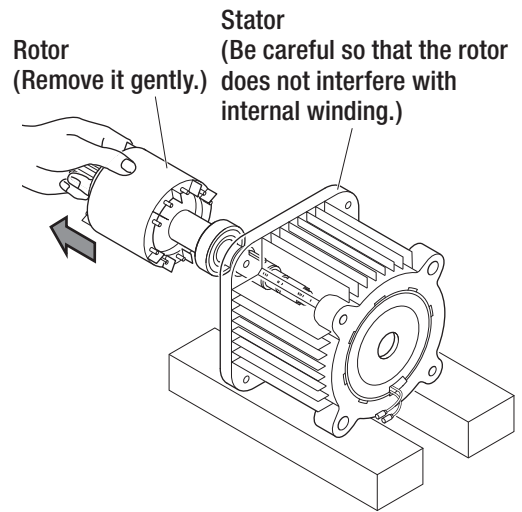

7 Disassembling the body part

(1) Remove the 3 socket bolts from the body.

- DO NOT use impact and electric screwdriver, use a hand tool such as a hexagonal wrench, and then loosen gently.
- When the socket bolt is stuck in the middle of loosening, do not force it to loosen, and turn it in the opposite direction (clockwise) sometimes for loosening safely.

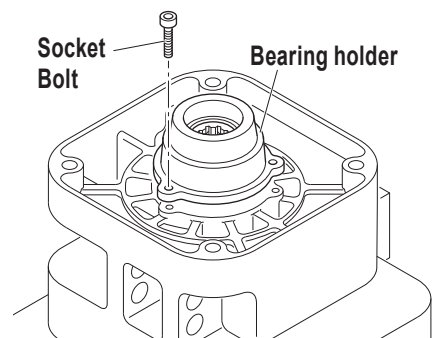

- (2) Place the body sideways. Hammer the pinion gently to remove the bearing holder (including the pinion).

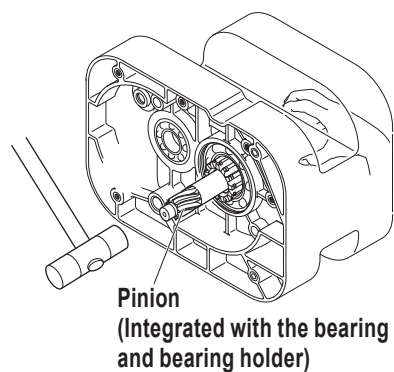

- (3) Hammer the load sheave gently as shown in the figure to remove it.

- Hold the load sheave with hands to prevent it from falling.
- For Basic main bodies B and C, Chain Guide B is not fixed. Be careful not to damage Chain Guide B.

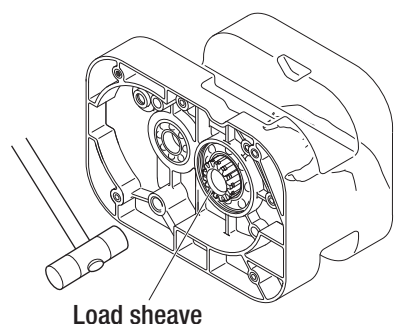

- (4) Remove the 4 screws, and remove Chain Guide B.

- There is no Pan-head machine screw for Basic main bodies B and C.

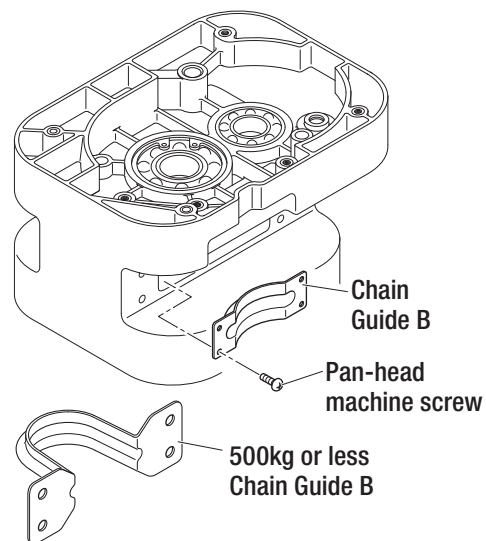

- (5) Remove the snap ring as required, and remove the bearing and oil seal built into the body.

- If the oil seal is removed, replace it with a new one upon reassembly.

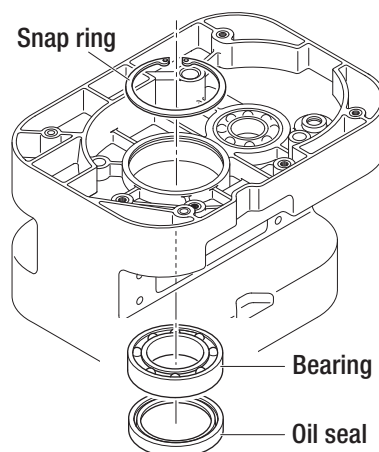

Reassembly procedure

DANGER



Mandatory

- Do not perform reassembly using parts exceeding application limits.
- For parts to be replaced with new parts upon reassembly, refer to page 3.
- Tighten the bolts and nuts securely with the specified torques.
- Make sure to perform installation and retaining measure (i.e. opening legs) for the split pin.
- Apply oil, grease, and screw lock as instructed.

Failure to follow this instruction may result in death or severe injury.

1 Assembling the body

- (1) Mount the snap ring to Housing A of the body, and press-fit the bearing and then oil seal. (Apply oil to Housing A in advance.)

- Make sure that the snap ring is fully inserted to the slot.
- Turn over the body, and press-fit the bearing until it reaches the snap ring.
- Insert a new oil seal.
- Apply machine oil on the oil seal, and install it so that the flat part faces the direction as shown in the figure.
- After installation, apply additional oil on the lip circumference.

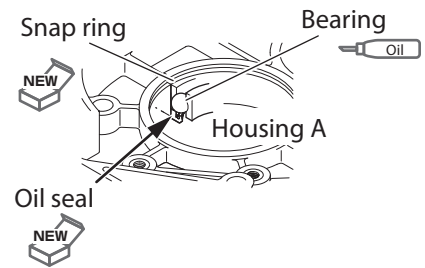
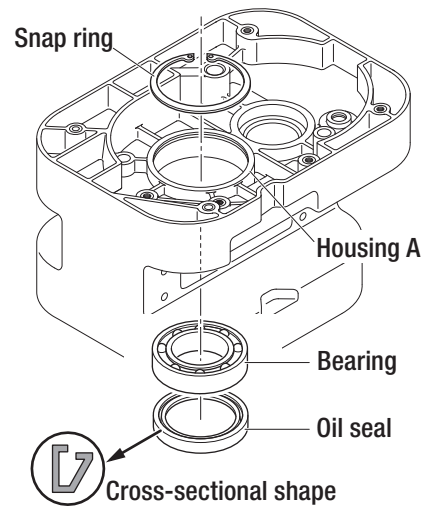

- (2) Turn over the body, and press-fit the bearing until it reaches the snap ring.
- Apply oil on all bearings and insert them using a proper jig.

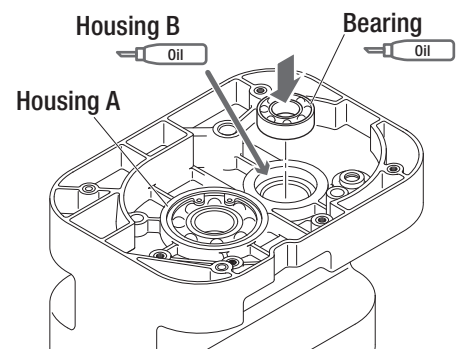

(3) Install the oil seal with machine oil applied to the load sheave securely.

- Install it fully so that the flat part faces the direction as shown in the figure.
- After installation, apply additional oil on the lip circumference.

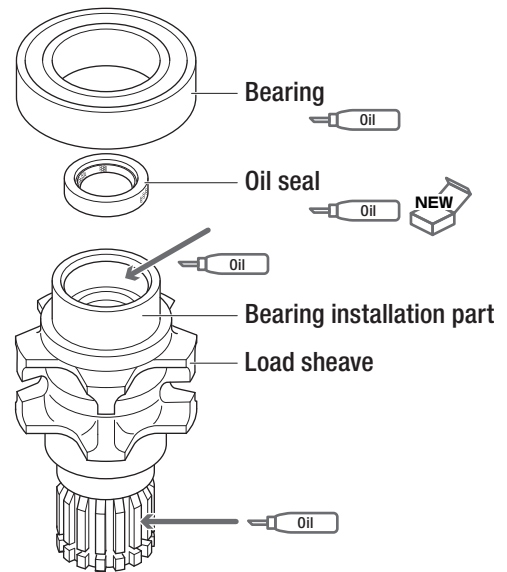

(4) Install the bearing to the load sheave.

(5) Install Chain Guide B to the body securely.

- Use a Pan-head machine screw to install Basic main bodies D, E, and F.
- Basic main bodies B and C are fastened together with Chain Guide A, so no Pan-head machine screw is required.

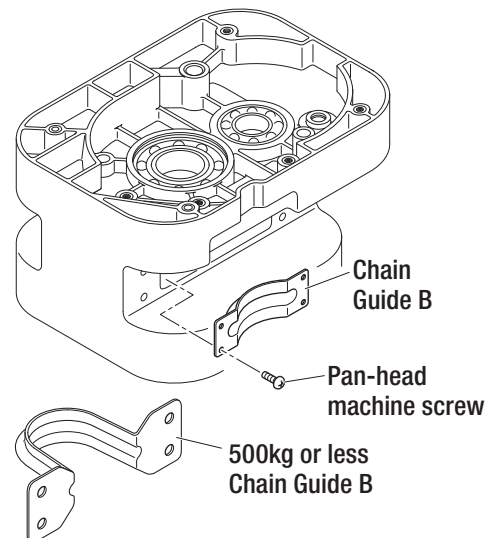

(6) Insert the load sheave to the body.

- Place the body on a wooden block, and insert the load sheave fully by using a proper jig not to hit the bearing. Be careful not to scratch the oil seal during operation.
- If it is difficult to insert the bearing, hammer it gently with a plastic hammer.
- For Basic main bodies B and C, Chain Guide B is not fixed. Be careful not to damage the load sheave and Chain Guide B.

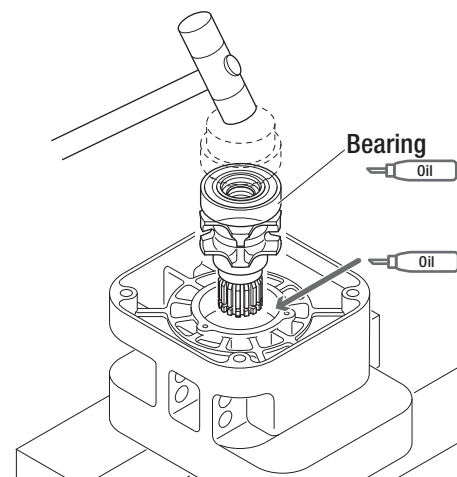

Reassembly procedure (continued)

- (7) Insert the pinion (with the bearing) to the bearing holder.

- If it is difficult to insert the pinion, hammer it gently with a plastic hammer.

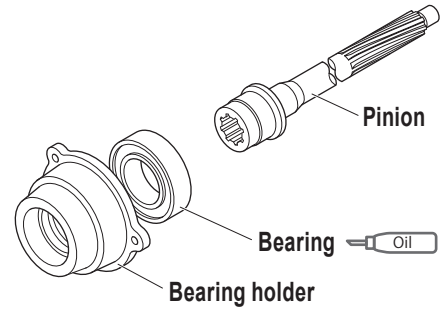

- (8) Insert the bearing bearer (integrated with the pinion) to the body.

- Make sure there is no gap between the junction faces of the bearing holder and body.
- Be careful not to scratch the oil seal with the gear part of the pinion.
- Apply screw lock on the 3 socket bolts and tighten them.
- Apply molybdenum disulfide grease Molytherm No.2 lightly and evenly onto the spline part of the pinion.

Molytherm No.2: 2g
 Tightening torque M5: 8.4 N·m
 M6: 10.8 N·m

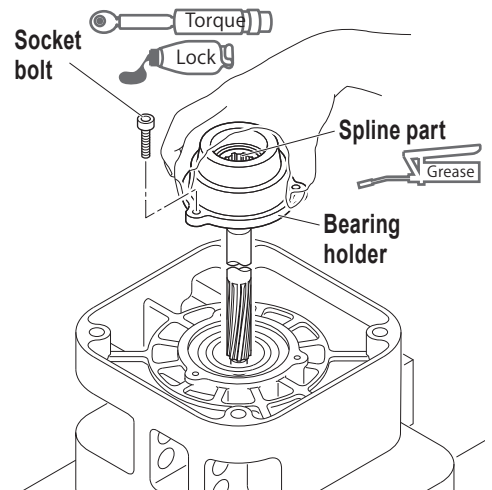

DANGER



Mandatory

- Apply the specified grease on the spline part of the pinion.

Failure to follow this instruction may cause a falling load due to wear or damage of parts and result in death or severe injury.

- (9) Install the guide roller to Chain Guide A with the roller pin.

- Guide roller is provided for Basic main bodies D, E, and F.

- (10) Install Chain Guide A to the body with the 4 socket bolts.

- Tighten the socket bolts at the following torque.
- Chain Guide B is fastened together for Basic main bodies B and C.

Tightening torque M6: 10.8 N·m
 M8: 37.2 N·m

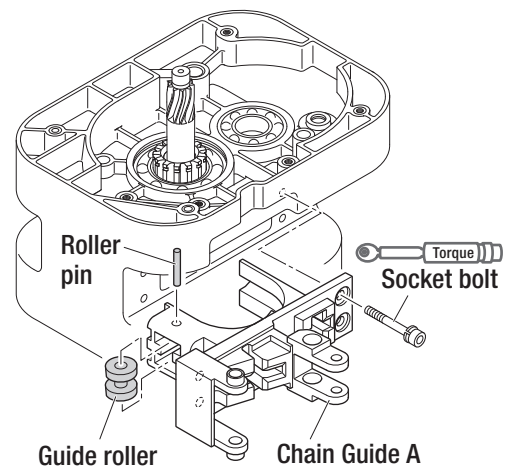

2 Assembling the motor and electromagnetic brake

- (1) Press-fit the bearings at 2 locations on the motor shaft.

- (2) Install a Snap ring between the key groove and Bearing.

- Install it so that the key slot and snap ring opening are in the opposite sides.
- Some models do not require any Snap rings.

- (3) Install the key to the motor shaft.

- Install it fully into the key slot.

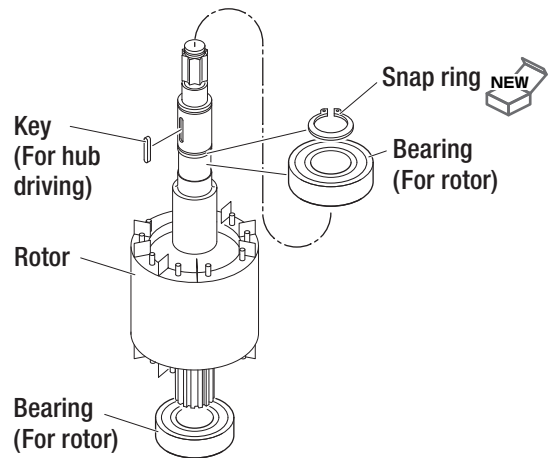

- (4) Insert the rotor (including the motor shaft) to the stator.

- Insert it from the tip of the key installation side of the motor shaft, and insert the bearing to the housing inside the stator.
- When inserting the rotor, be careful not to scratch the stator winding.

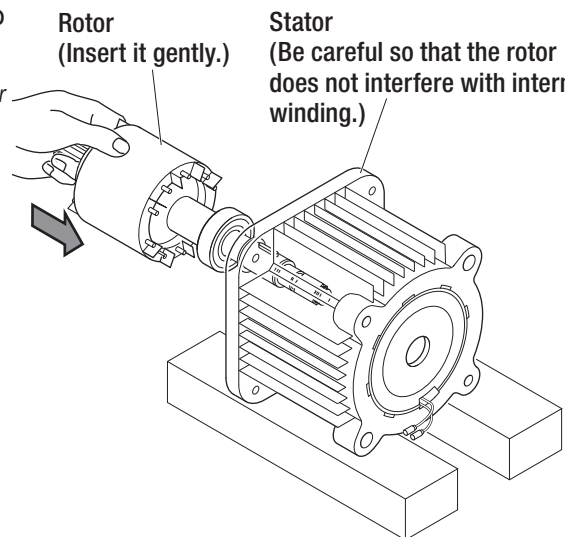

- (5) Mount the backing plate on the bottom of the motor shaft for supporting the rotor, and make the motor frame upright.

- Draw the 2 lead wires for braking out from the stator upper opening.

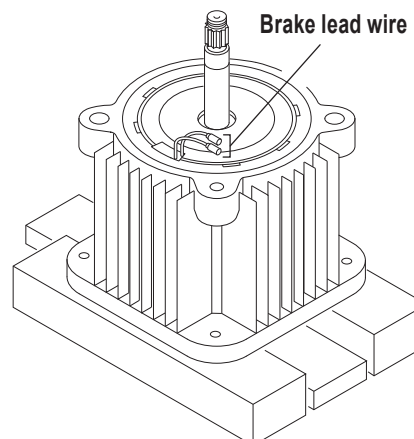

- (6) Install the hub to the motor shaft.
- If it is difficult to insert, hammer it gently with a plastic hammer.
 - Press down until the slot to which a snap ring is mounted is visible.

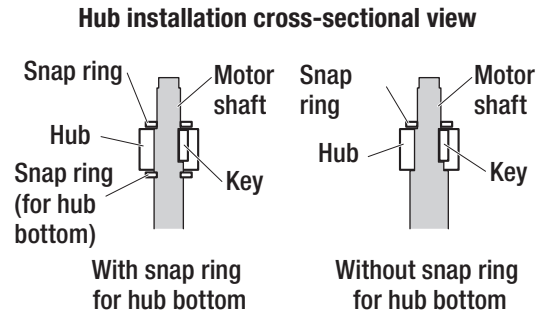

- (7) Install a snap ring to the hub top.
- Make sure that the snap ring rotates smoothly.

! DANGER

! Mandatory

- Install the key and snap ring securely.

Failure to follow this instruction may result in death or severe injury.

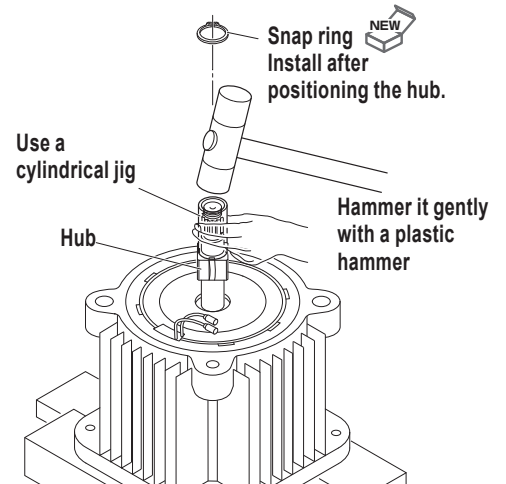

- For Spline hub
 - After installing the spline hub to the motor shaft, install the 3 hub springs to the correct positions as shown to the right.

! CAUTION

! Mandatory

- Make sure that the hub spring is installed to the spline hub correctly.
- Check the shape of the spline hub.

Failure to follow this instruction may cause abnormal sound, vibration or damage of property.

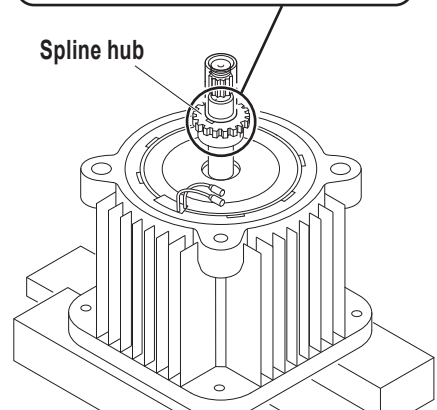
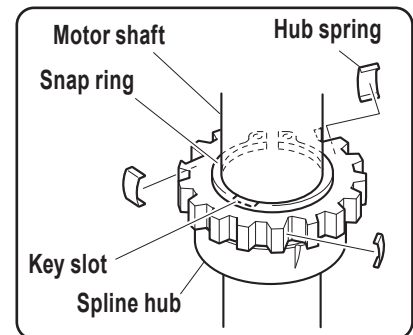

(8) Install the electromagnetic brake with the 3 socket bolts.

- Check the orientation of the electromagnetic brake. Refer to the position data recorded upon disassembly.
- Check that the lead wire is not too long or too short for connection.
- Perform wire connection properly by referring to the figure.

Tightening torque M6: 10.8 N·m

M8: 37.2 N·m

Spring lock washer : Yes

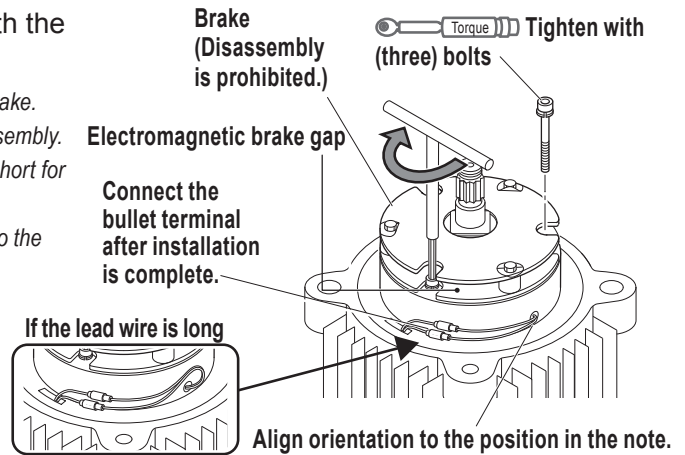

CAUTION



Mandatory

- Make sure the lead wire is along the side of the brake. If the lead wire is long, be sure to fold it as shown in the figure.

There is a risk that the lead wire enters the gap of the brake and touches the inside to cause damage.

(9) Install the V ring.

- Insert the V ring to the motor (pinion) shaft.
- Insert the V ring in the orientation as shown in the figure until it touches the groove of the motor shaft.

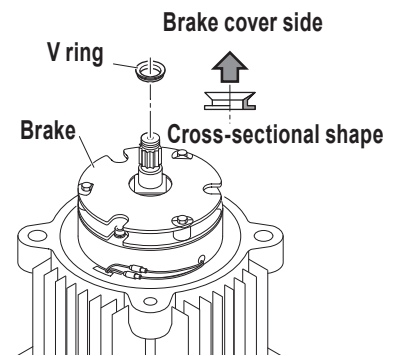

(10) Install the set pin, and then install the brake cover.

- The center hole will slide against the V ring, so make sure to apply Molytherm No.2.

Molytherm No.2 : Several grams

CAUTION



Mandatory

- Check that there is no slack in the lead wire, and attach the cover while holding the lead wire so as not to pinch it.

There is a risk that the lead wire enters the gap of the brake and touches the inside to cause damage.

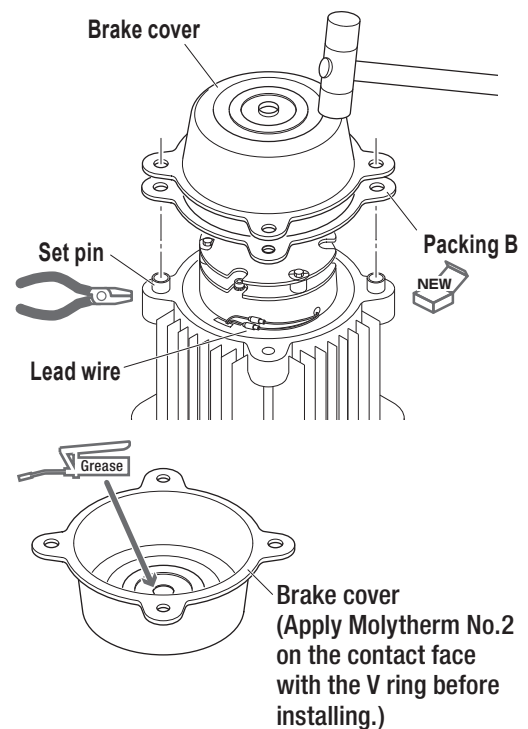

(11) Install the fan.

- If the fit is hard and it is difficult to install, set a proper jig and hammer it gently with a plastic hammer.
- Be careful not to hammer the motor shaft or fan directly.

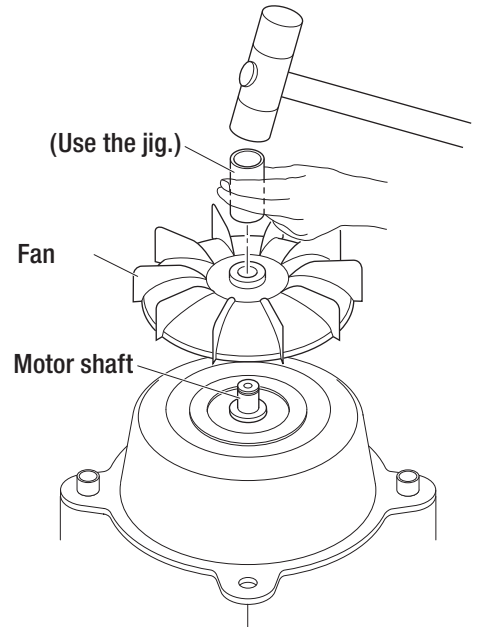

(12) Install a snap ring.

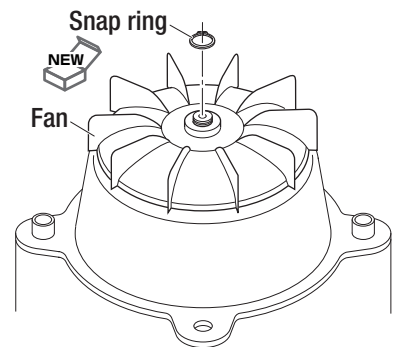

(13) Install the Fan cover to the Stator with the Socket bolt.

- Be careful of the orientation of the fan cover (align it with the set pin).
- Apply screw lock to the screw hole side and tighten the bolt.

Tightening torque M5: 4.7 N·m
M6: 7.9 N·m



CAUTION



Mandatory

- When installing the fan cover, observe the tightening torque value to tighten the socket bolt.

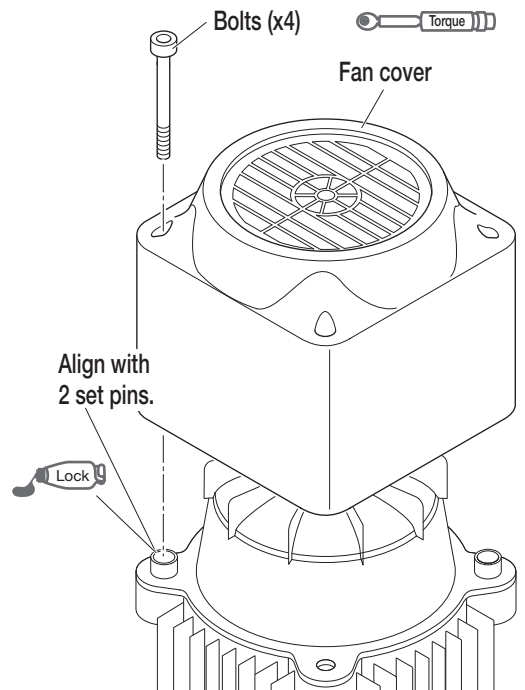
Failure to follow this instruction may cause damage or crack of the fan cover.



3 Connecting the motor and body

- (1) Install the 2 set pins and Packing M to the motor.

- (2) Mount the body on the motor.
- Mount it so that the Chain Guide A side of the body is in the name plate side of the motor.
 - Be careful so that the lead wire won't get caught between the body and stator.
 - Fit the spline hole at the pinion bottom to the spline shaft at the motor shaft tip by rotating the pinion.
 - Hammer the body gently with a plastic hammer to connect the stator without any gap.
 - Apply screw lock on the 4 socket bolts, and install the stator and body.

Tightening torque	M6 : 10.8 N·m
	M8 : 34.3 N·m
	M10 : 39.2 N·m
	M12 : 58.8 N·m

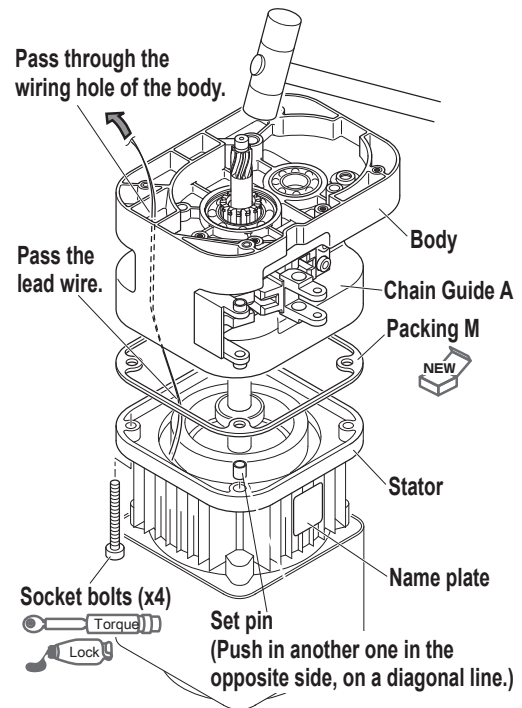

- (3) Install the limit lever to Chain Guide A at the body bottom.

- Fit the limit lever to Chain Guide A, insert the lever pin with the limit lever spring installed, and align it with the hole position of Chain Guide A to install it.

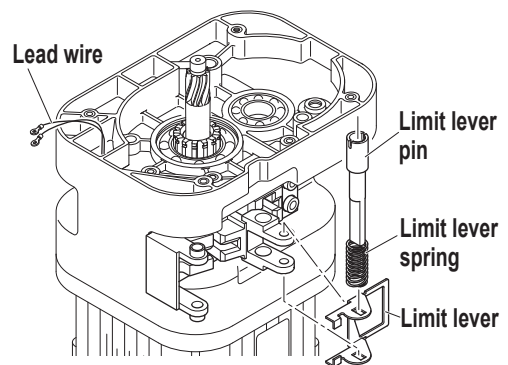

4 Installing the load chain

(1) Install the load chain so that the welded part comes outside of the load sheave.

- Insert it to the main body from the horizontal link (or vertical link for capacity over 3t)

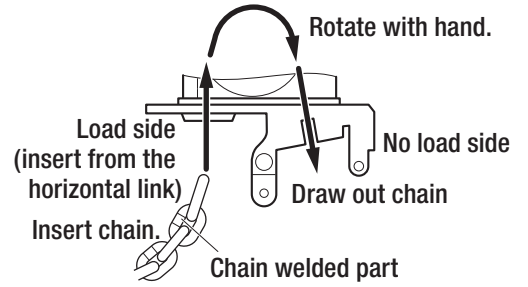

(2) Insert the load chain from the load side (bottom hook side) of Chain Guide A, wind it up by rotating the load sheave manually to guide it out to the load chain outlet (no load side).

- When it engages with the load sheave, tilt the body to the no load side, and rotate the load sheave manually to guide the load chain out without getting it entangled.

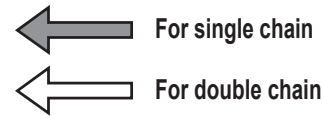
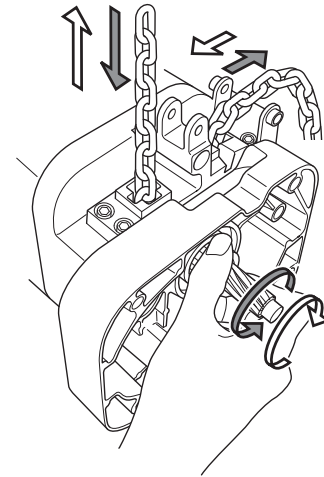

● Installation for the double chain type

- Insert the load chain from the no load side of Chain Guide A, wind it up by rotating the load sheave manually to guide it out to the load chain outlet (load side).

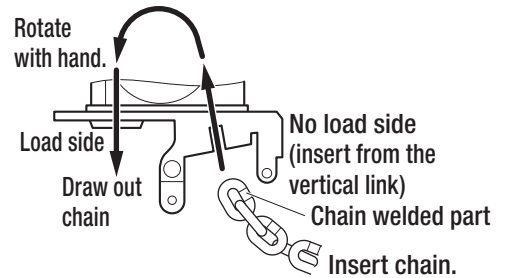

⚠ DANGER



Mandatory

- Insert the load chain so that the welded part comes outside when it is engaged with the load sheave.

Failure to follow this instruction may cause defective operation or abnormal wear and result in severe injury due to a falling load.

- (3) Re-check the orientation of the load chain, and check for any twist.

- (4) Install the stopper and cushion rubber or chain spring to the 3rd link from the end of the no load side load chain as they were before disassembly.

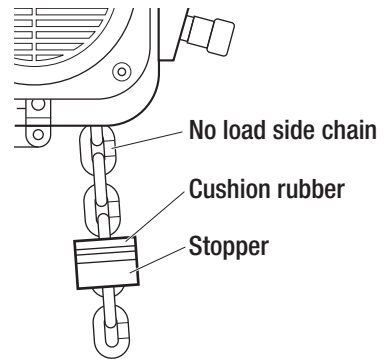

5 Assembling the gear parts

● Double reduction

• Mechanical brake specification (option)

- (1) Insert the pawl spring and pawl to the pawl shaft, and lock them with a snap ring.
 - Check the orientation so that the pawl is in engagement with the ratchet disc.

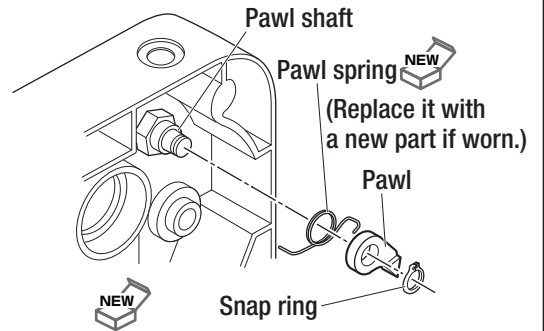

- (1) Insert the load gear to the load sheave, and lock it with a new snap ring.
 - Make sure that the snap ring is inserted fully.
 - For the orientation of the load gear to install it correctly, refer to Figure A.

Fig. A Orientation of the load gear

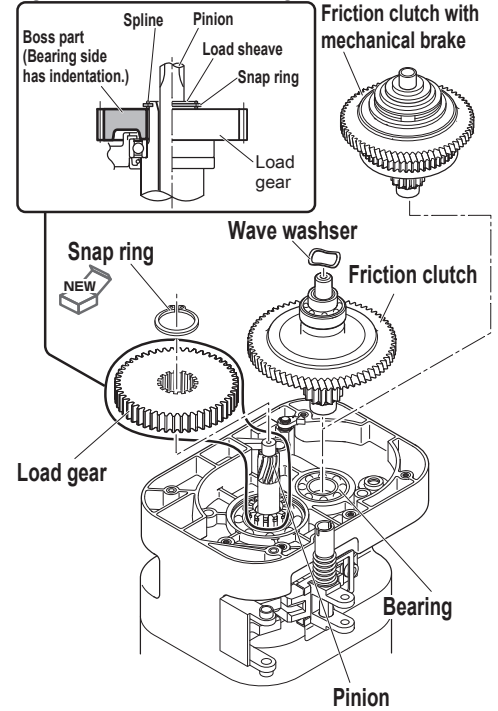

- (2) Install the friction clutch, and mount the wave washer.

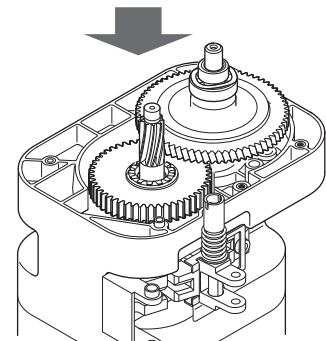

● Friction clutch with mechanical brake specification (option)

- Install the friction clutch with mechanical brake while checking the engagement between the ratchet disc and pawl.
- (No wave washer available.)

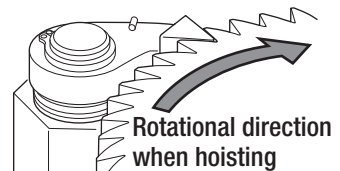

⚠ DANGER



Prohibited

- Do not adjust the friction clutch or friction clutch with mechanical brake.

Failure to follow this instruction may result in death or severe injury.

● Triple reduction

- (1) Insert the load gear to the load sheave, and lock it with a new snap ring.

- For the orientation of the load gear to install it correctly, refer to Figure A.

- (2) Place the set pin to the body, and install the gear holder plate with the 3 socket bolts.

Tightening torque M6: 10.8 N·m

M8: 37.2 N·m

Spring lock washer : Yes

- (3) Install the friction clutch, and mount the wave washer.

- (4) Insert Gear B to the bearing of the gear plate.

- For the friction clutch with mechanical brake specification (option), install additional parts as in the case of the double reduction specification.

(Refer to the previous page.)

Fig. A Orientation of the load gear

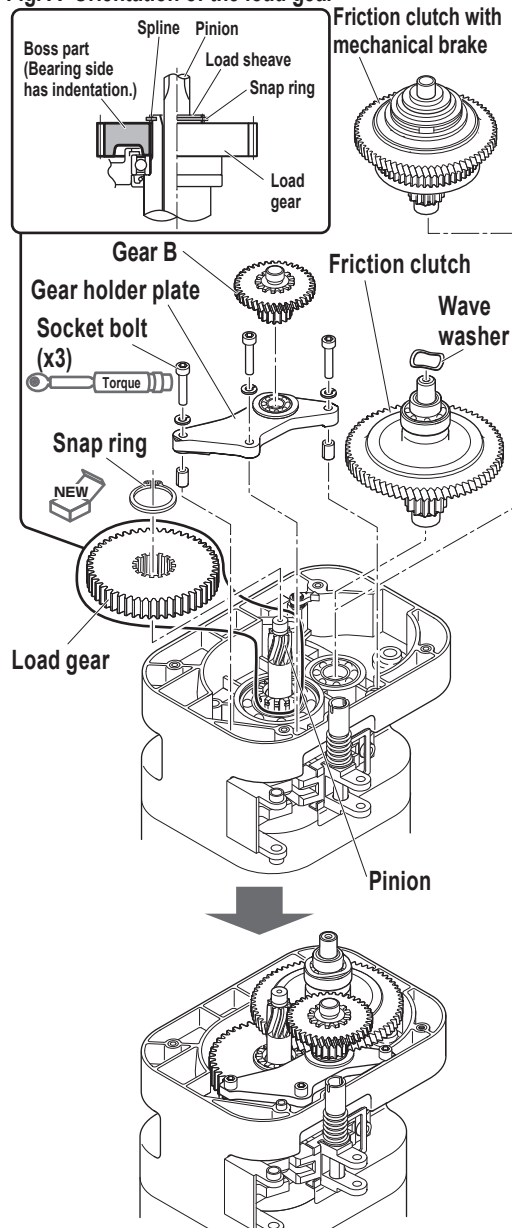

Reassembly procedure (continued)

- (3) Press-fit the bearing for the pinion to the gear case using a proper jig.

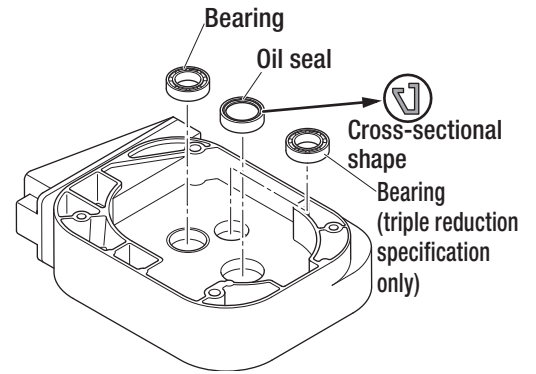

- (4) Install the oil seal to the gear case using a proper jig.

- (5) Install the friction plug by hammering it with a plastic hammer.

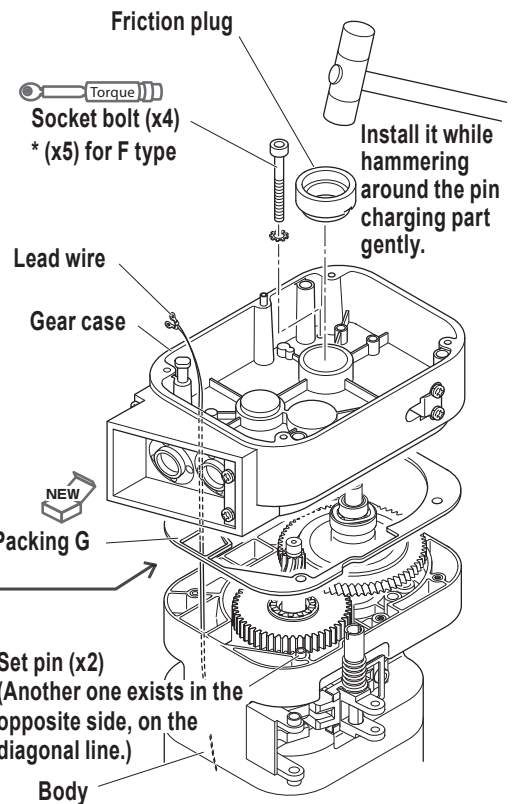

- (6) Mount a new Packing G on the body, and install the gear case by hammering it with a plastic hammer.

- At the same time, install the 2 set pins.
- Be careful so that the lead wire won't get caught.
- Temporarily install the gear case with the 4 socket bolts (5 for F type), and tighten them sequentially, alternating diagonally.
- For Friction clutch with mechanical brake specification, install Spacer M with Packing G between Gear case and the body.

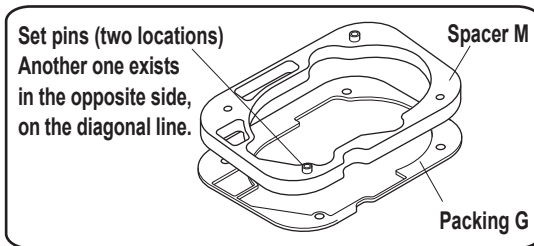

Tightening torque M6: 10.8 N·m
M8: 37.2 N·m
Toothed lock washer : Yes

- (7) Install the limit switch from the gear case side (inside of the panel plate) (if removed).

- Replace O ring attached to the shaft of the limit switch with a new one and apply oil to it.
- Align the shaft salient of the limit switch to the notch of the lever pin when inserting it.
- Insert it gently not to scratch the O ring.
- Perform wiring of the limit switch.

◆ After installation, move the limit lever manually and check if it performs follow-up operation.

Tightening torque M6: 10.8 N·m
Spring lock washer : Yes

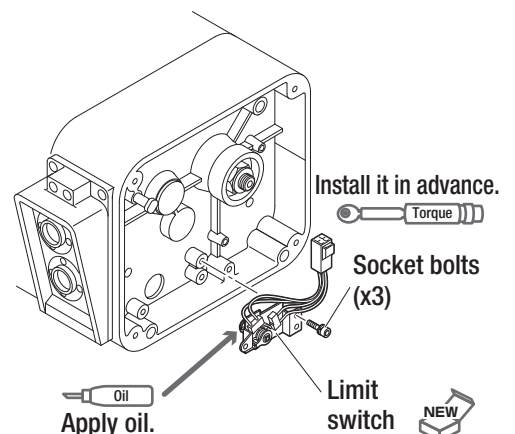

6 Installing the top hook

● Assembling the top hook (Basic main bodies B, C, D, and E)

(1) Install the top hook by inserting the 2 top pins.

(2) Install Plate A (for Top pin) with Socket bolt (1 piece) and Shaft clip on the opposite side.

- Fix and lock the top pin with the plate A (for Top pin) and shaft clip.
- Push the shaft clip fully until it clicks.

Tightening torque M6: 10.8 N·m

Spring lock washer: Yes

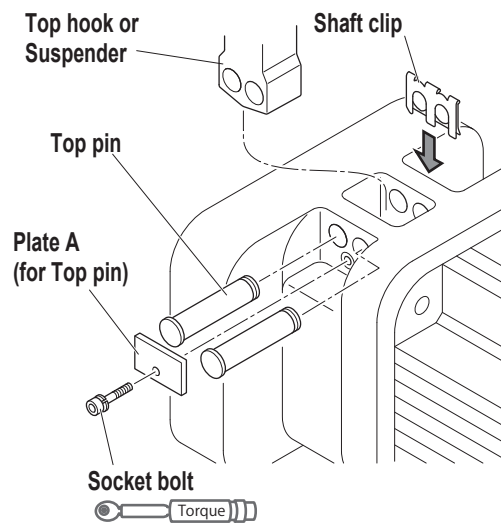

(3) When connecting to Motorized trolley, install Suspender instead of Top hook.

● Assembling the top hook (Basic main body F)

(1) Install the 2 O rings to the top pin and fixing shaft.

- Apply Molytherm No.2 around O ring.
Molytherm No.2: Several grams

(2) Install the top hook or suspender while inserting Top pin.

(3) Install Plate A (for Top pin) with the 2 socket bolts.

Tightening torque M6 : 10.8 N·m

Spring lock washer: Yes

(4) Insert the fixing shaft plug.

(5) Install the Plate A (for fixing shaft) with the 2 pan-head machine screws.

Tightening torque M5 : 8.4 N·m

(6) Insert the shaft plug and O ring, and fixing shaft plug and O ring to the hole of the top pin and fixing shaft of the stator side.

- If they were removed during disassembly, insert them before connecting the motor and body as described on page 26.

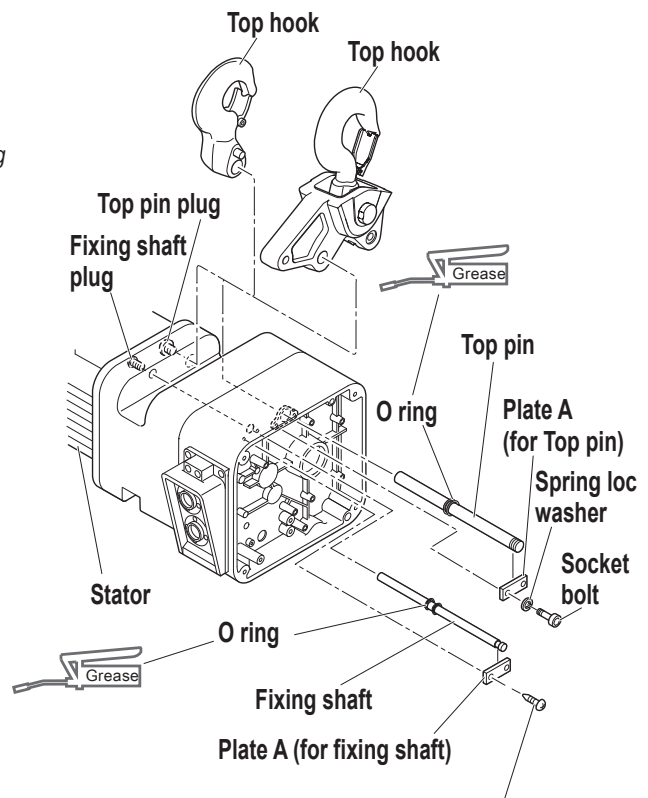

● Double chain

When the reassembly of the top hook of Basic main body E/F is complete, install the load chain.

- (1) Insert Load chain from the load side of Chain Guide A through Limiting plate, Chain spring, Bottom hook, and Chain spring in that order.
 - Make sure Load chain is not twisted
- (2) Install Stopper on the specified number of the link from the Load chain terminal.
 - Link number where Stopper is installed
2.8t and 3t: 8th link
4.8t and 5t: 7th link
- (3) Install the load chain to the connection yoke while inserting the chain pin.
 - Check Load chain for any twist.
- (4) Tighten the slotted nut to the split pin slot of the chain pin, and insert the split pin.
- (5) Bend the split pin to lock.

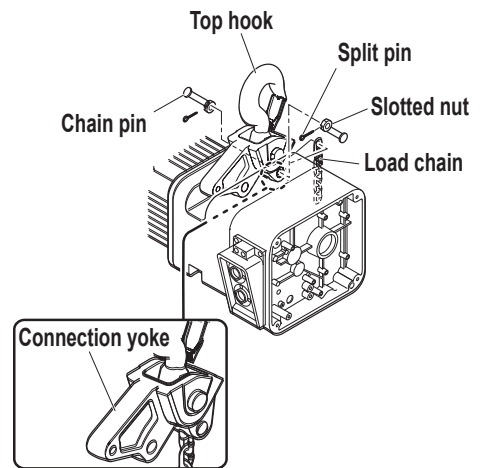
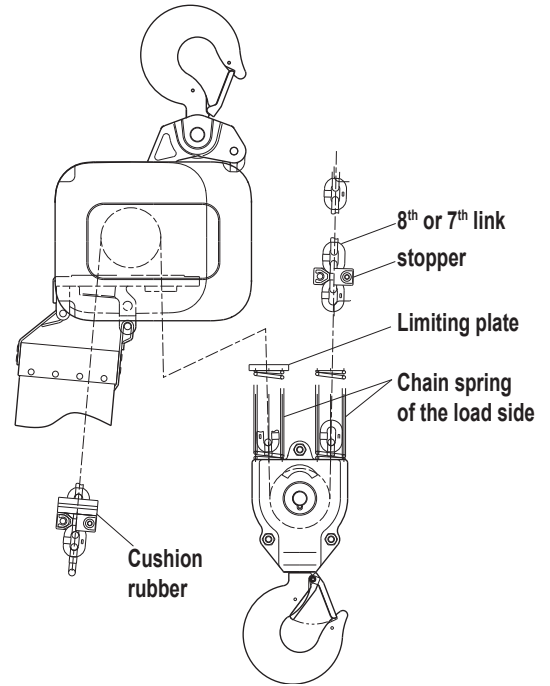

! DANGER



Prohibited

- Make sure Load chain is not installed with a twist.

Failure to follow this instruction may cause a falling load due to broken load chain or damaged parts, resulting in death or severe injury.

7 Assembling the controller cover

Single speed type

CAUTION



Mandatory

- Be careful so that your finger won't get caught by the panel plate.

- (1) Fix the plate securely with the 3 setscrews.
- Align the elongate hole of the plate to the fulcrum pin head of the gear case, and rotate it slightly for position it.

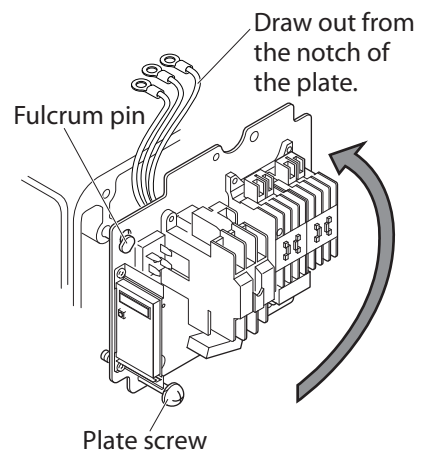

- (2) Reconnect the motor lead wire.
- Check the wire connection by looking at the connecting diagram. The connecting diagram is attached on the inside of the controller cover.

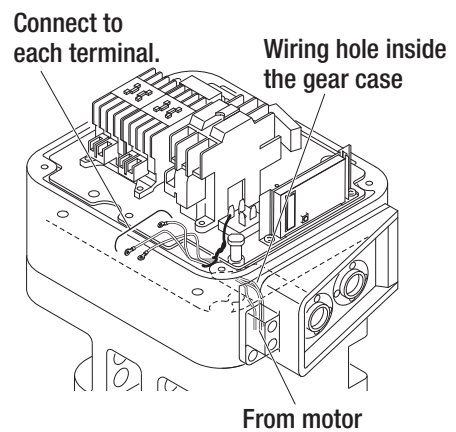

- (3) Install the cover belt to the controller cover (if removed).
- Be careful so that the cover suspender faces the direction as shown in the figure.

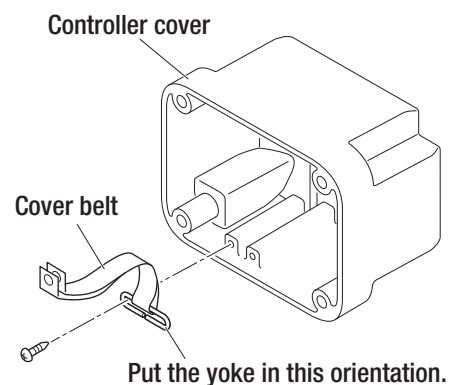

Reassembly procedure (continued)

- (4) Install the cover belt to the gear case.
- Pass the cover belt through Controller Cover Packing C.
 - Tighten the socket bolt while holding the controller cover with hands.

* For B type, install the cover belt before fixing the plate.

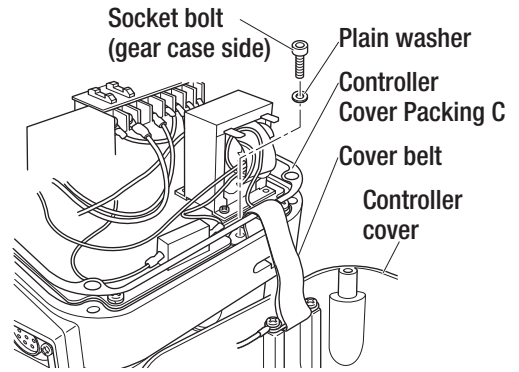

- (5) Install the controller cover with 4 socket bolts (spring lock washer required).

Tightening torque M5: 8.4 N·m
M6: 10.8 N·m
Spring lock washer : Yes

* When making a direct connection, do so after connecting the power supply cable and the push button cord.

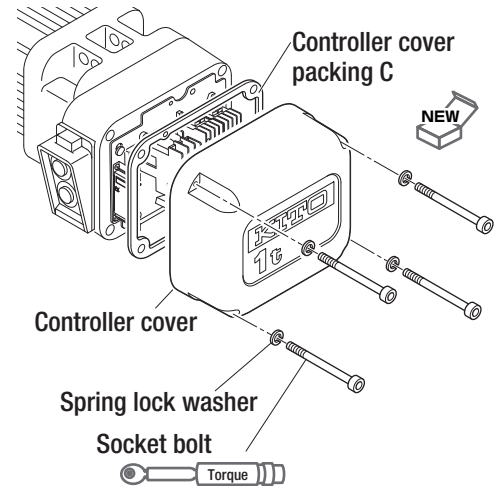

- (6) Insert the push button cord plug to the socket, and install the protection wire to the body.

• Install Cable Support L with the protection wire attached to the body with the 2 pan-head machine screws.

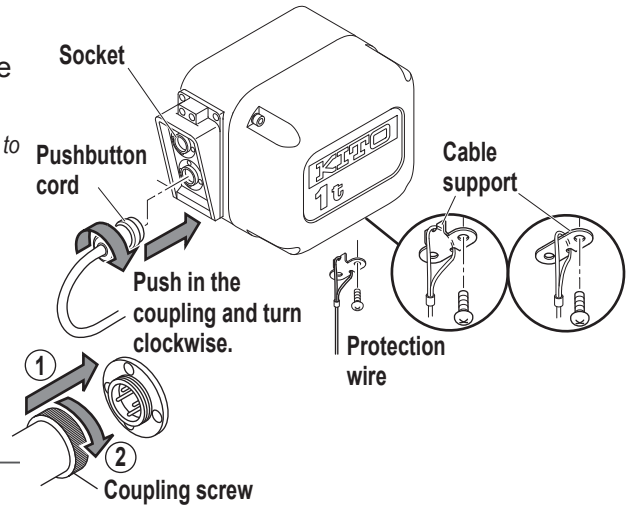

- (7) Insert the power cable plug to the socket.

- (8) Install the cable support arm to the body with the 2 pan-head machine screws.

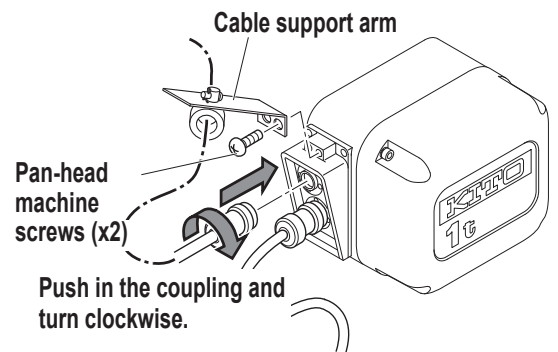

(9) Connect the power supply cable (upper side) and the push button cord (lower side) to Holder C, and then turn Holder A to connect it.

- For details, refer to *ER2 Series Electric Chain Hoist Owner's Manual* (separate document).

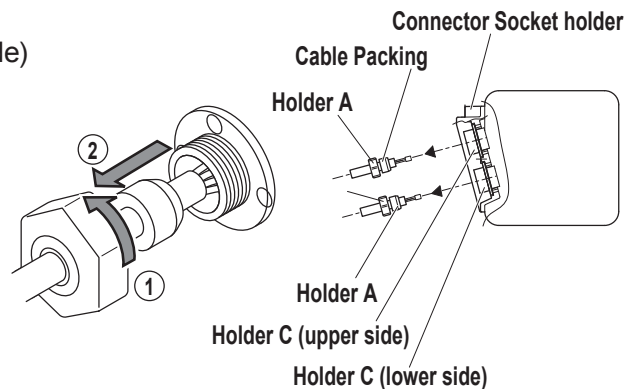

(10) Install the chain bucket to the main body.

- For information on how to install various types of buckets, refer to *ER2 Series Electric Chain Hoist Owner's Manual* (separate document).

Dual speed inverter type (Basic main body B/C type)

CAUTION



Mandatory

- Be careful so that your finger won't get caught by the panel plate.

- (1) Fix the plate securely with the 3 setscrews.
 - Align the elongate hole of the plate to the fulcrum pin head of the gear case, and rotate it slightly for position it.

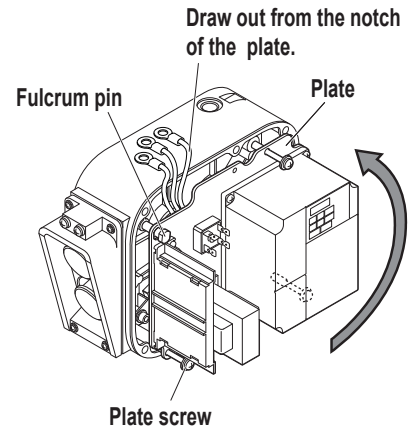

- (2) Reconnect the motor lead wire.
 - Check the wire connection by looking at the connecting diagram. The connecting diagram is attached on the inside of the controller cover.

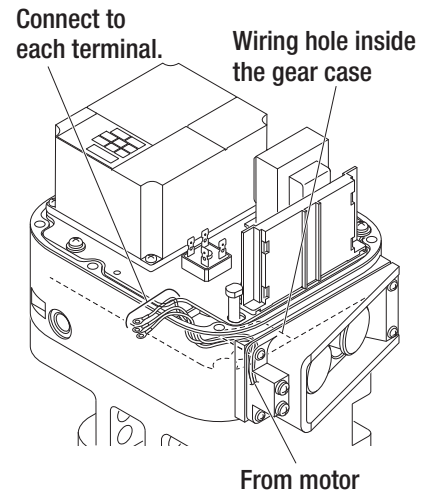

- (3) Install the cover belt to the controller cover (if removed).
 - Be careful so that the cover suspender faces the direction as shown in the figure.

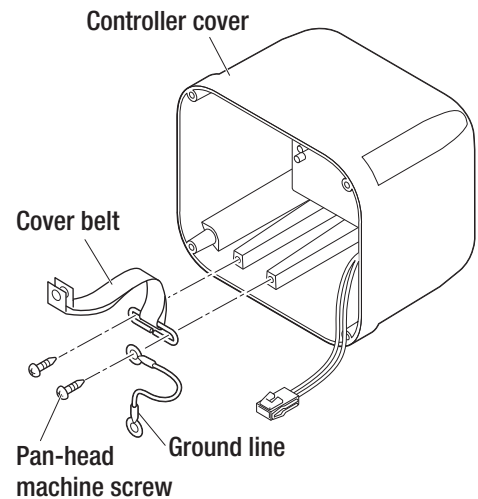

(4) Install the cover belt to the gear case.

- Pass the cover belt through Controller Cover Packing C.
- Tighten the socket bolt while holding the controller cover with hands.

Tightening torque M6: 10.8 N·m

Spring lock washer : Yes

Plain washer : Yes

- * For B type, install the cover belt before fixing the plate.

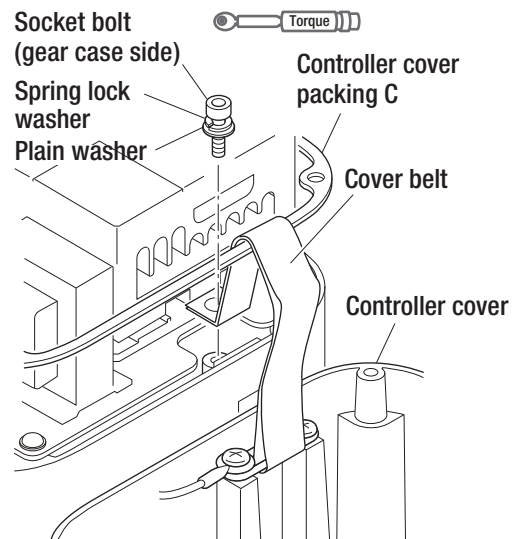

(5) Connect the wiring to Controller cover connector, and connect the ground line to the ground terminal of plate.

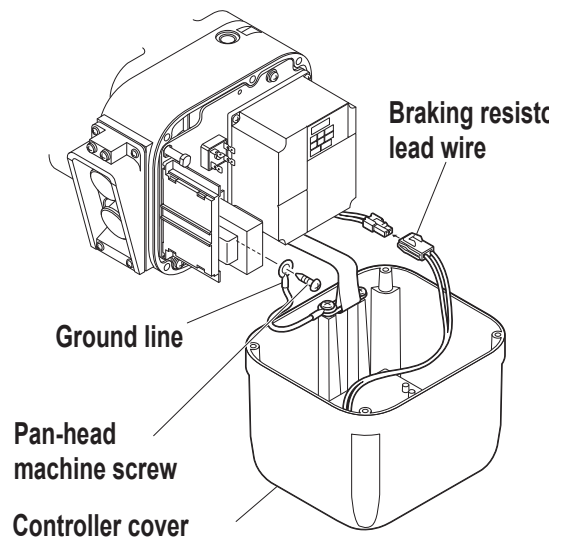

(6) Install the controller cover with 4 socket bolts (toothed lock washer required).

Tightening torque M5: 8.4 N·m

M6: 10.8 N·m

Toothed lock washer : Yes

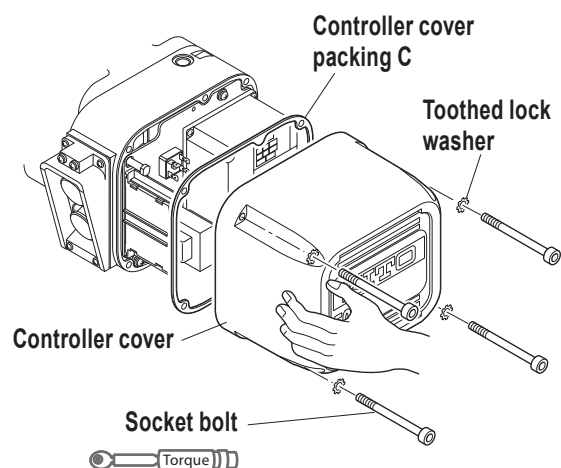

Dual speed inverter type (Basic main body D/E/F type)

CAUTION



Mandatory

- Be careful so that your finger won't get caught by the panel plate.

- (1) Fix the plate securely with the 3 setscrews and the inverter with the 2 pan-head machine screws.

- When installing the inverter, be careful so that the lead wire won't get caught.

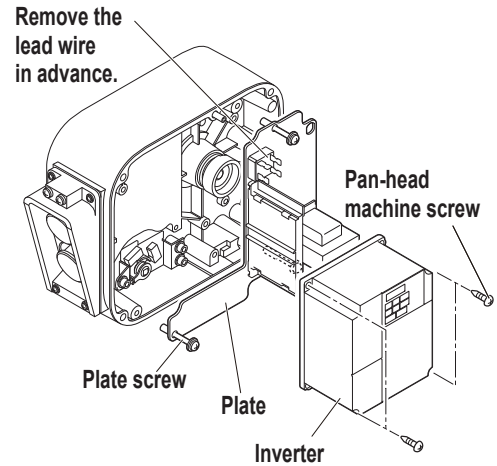

- (2) Reconnect the motor lead wire.

- Check the wire connection by looking at the connecting diagram. The connecting diagram is attached on the inside of the controller cover.

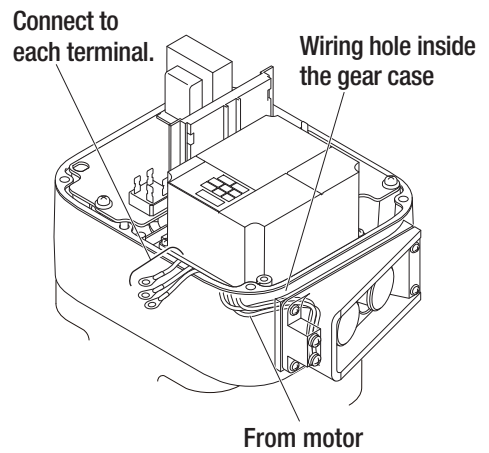

- (3) Install the cover belt to the controller cover (if removed).

- Be careful so that the cover suspender faces the direction as shown in the figure.

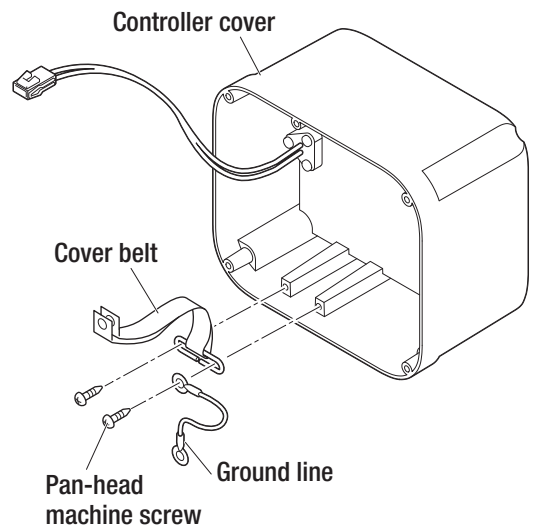

(4) Install the cover belt to the gear case.

- Pass the cover belt through Controller Cover Packing C.
- Tighten the socket bolt while holding the controller cover with hands.

Tightening torque M6: 10.8 N·m

Spring lock washer : Yes

Plain washer : Yes

- * For B type, install the cover belt before fixing the plate.

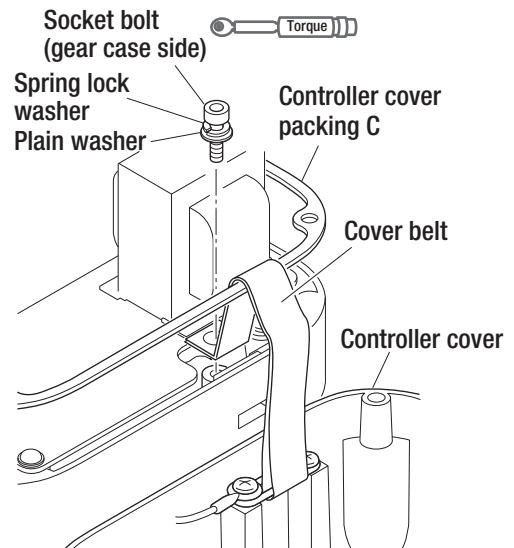

(5) Connect the wiring to Controller cover connector, and connect the ground line to the ground terminal of Plate.

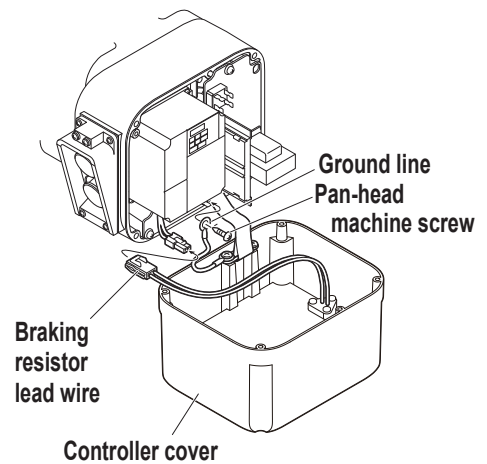

(6) Install the controller cover with 4 socket bolts (toothed lock washer required).

Tightening torque M5: 8.4 N·m

M6: 10.8 N·m

Toothed lock washer : Yes

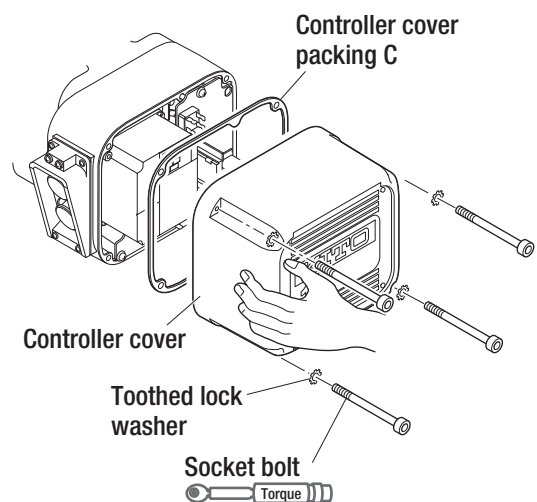

8 Installing the bottom hook (if removed from the chain)

CAUTION

Mandatory

- Check the load side of the load chain to install the bottom hook.

- Installing single type Bottom hook
 - For 2t or more, pass the limiting plate and chain spring through before installing the bottom hook.

- (1) Apply grease on Thrust bearing.

- (2) Face the smaller internal diameter of Thrust bearing to the A side (upper side) of Thrust Stopper to incorporate it into Hook.

- (3) Use 2 Thrust Stoppers to pinch the hook neck and incorporate Thrust collar A as to cover the outer circumference of Thrust Stopper A.

- (4) Assemble the incorporated Hook and the terminal link of Load chain as to nip them with Bottom yoke.

- (5) Put through a bolt, apply Screw lock before tightening.
 - Tightening torque M6: 19.6 N·m
 - M8: 34.3 N·m
 - M10: 63.7 N·m
 - M12: 63.7 N·m
 - Spring lock washer: Yes

- (6) Check if Hook rotates smoothly.

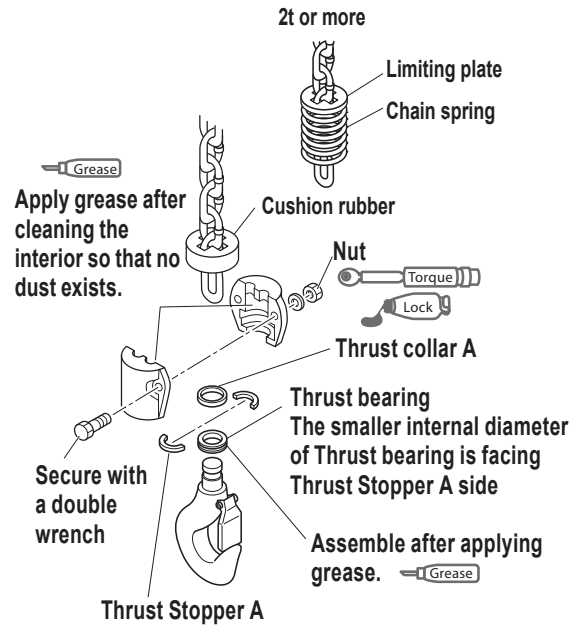

Details of assembling Thrust bearing

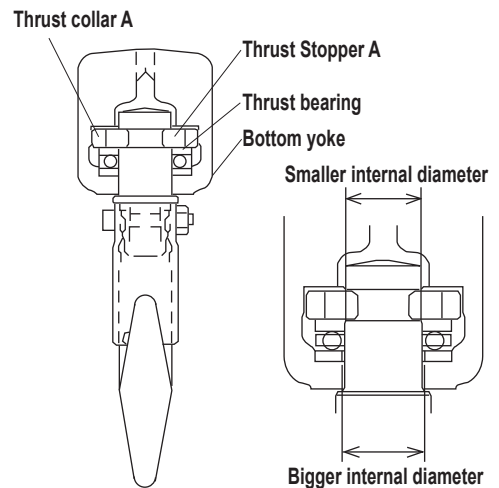

DANGER

Prohibited

- Make sure that Thrust collar A, Thrust Stopper A, and Thrust bearing are incorporated correctly as shown in the figure above.

Failure to follow this instruction may result in death or severe injury due to a falling load.

● Installing double type Bottom hook

- (1) Apply grease to Thrust bearing.

- (2) Face the smaller internal diameter of Thrust bearing to the A side (upper side) of Thrust Stopper to incorporate it into Hook.
(Refer to the details of assembling Thrust bearing)

- (3) Use 2 Thrust Stoppers to pinch the hook neck and incorporate Thrust collar A as to cover the outer circumferential of Thrust Stopper A.
(Refer to the details of assembling Thrust bearing)

- (4) Apply grease to the Bottom shaft assembly and needle bearing of Idle sheave assembly.

- (5) Incorporate the Bottom shaft assembly into the incorporated Hook and Idle sheave assembly as to nip them with Bottom yoke.

- (6) Put through a bolt, apply Screw lock before tightening.
Tightening torque M10: 63.7 N·m
M12: 63.7 N·m
Spring lock washer: Yes

- (7) Check if Hook rotates smoothly.

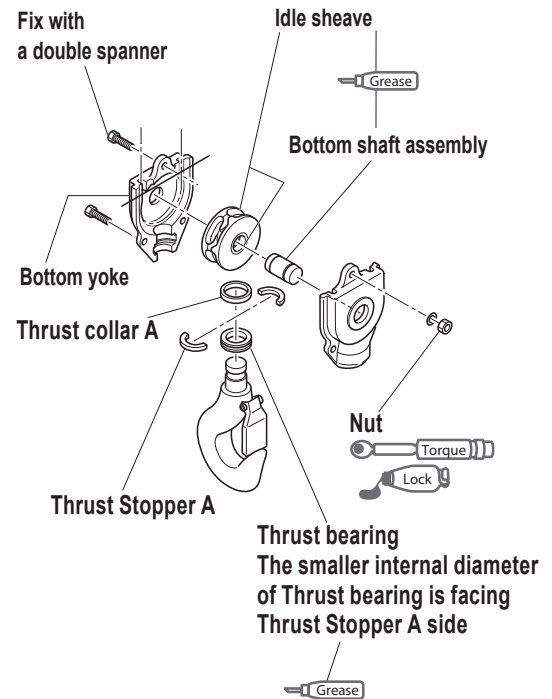

DANGER

Mandatory

- Make sure that Thrust collar A, Thrust Stopper A, and Thrust bearing are incorporated correctly as shown in the figure above.

Failure to follow this instruction may result in death or severe injury due to a falling load.

9 Oil filling

! DANGER



Mandatory

- Use genuine gear oil.

If you inject (or mix) any oil other than genuine oil, a major accident such as death or serious injury may occur due to a dropped load.

- (1) Tighten the oil plug (for waste oil hole) with a new packing securely.

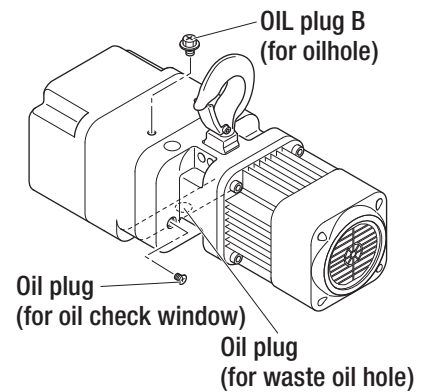

- (2) Inject gear oil from the oil plug B (for oilhole).

- Inject a proper quantity of oil by referring to the table on the next page.
Inject oil up to the proximity of the oil plug (for oil check window).

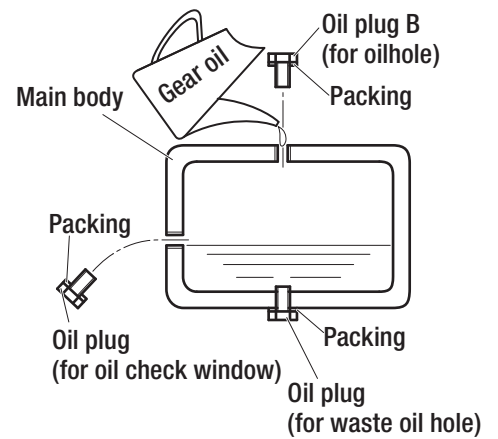

- (3) Place a new packing on the oil plug B (for oilhole) and tighten it.

- Use Kito genuine gear oil. (Refer to the oil quantity on the next page.)

* The friction clutch with mechanical brake specification has a sticker that indicates "With mechanical brake" (orange letters on a black background) to the right side seen from the main body controller cover.

⚠ DANGER



Mandatory

- Use the gear oil that comply with the specifications.

If you use different oil, a major accident such as death or serious injury may occur due to a dropped load.

The types of oil used are different for the friction clutch and friction clutch with mechanical brake.

Oil types and oil quantity for one unit of main body

Specification	Code	Gear oil amount (ml)	Oil manufacturer	Oil type
Friction clutch	ER2-001H, 001IH, 001HD, 003S, 003IS, 003SD	520	KITO genuine oil	KITO genuine oil
	ER2-003H, 003IH, 005L, 005IL, 005S, 005IS	540		
	ER2-005LD, 005SD	470		
	ER2-010L, 010IL, 010LD, 010SD	620		
	ER2-010S, 010IS	680		
	ER2-015S, 015IS, 015SD, 020L, 020IL, 020LD	1300		
	ER2-020S, 020IS, 028S, 028IS, 030S, 030IS	1900		
	ER2-020SD, 030SD	1800		
Friction clutch with mechanical brake	ER2-001H, 001IH, 003S, 003IS, 003SD	680	KITO genuine oil	KITO genuine oil
	ER2-005L, 005IL, 005LD, 005SD	820		
	ER2-003H, 003IH, 005S, 005IS	900		
	ER2-010L, 010IL, 010LD, 010SD	1050		
	ER2-010S, 010IS	1100		
	ER2-015S, 015IS, 015SD, 020L, 020IL, 020LD	2000		
	ER2-020S, 020IS, 028S, 028IS, 030S, 030IS	2500		
	ER2-020SD, 030SD	2300		
ER2-025S, 025IS, 025SD, 050S, 050IS, 050SD	2700			

* Do not top up on old oil. Use entirely new oil.

10 Operation check, etc.

After disassembly and reassembly, check the following items.

- (1) Check for parts that are left unused in reassembly.
 - If any part is left, perform disassembly and reassembly again for correct assembly.
- (2) Perform daily inspection.
 - For details, refer to "Daily inspection" in ER2 Series Electric Chain Hoist Owner's Manual (separate document).
- (3) After checking that no error occurs with no load, perform an operation test with a rated load.
 - For details, refer to "Regular inspection" in ER2 Series Electric Chain Hoist Owner's Manual (separate document).

Memo

A series of horizontal dotted lines for writing.



KITO

URL. <http://www.kito.com>