

ER2 Twin Hook Electric Chain Hoist **(250kg to 5t)**

Operation Manual **(TWER2/TWER2M/TWER2SP/TWER2SG)**

Introduction

KITO Twin Hook Electric Chain Hoist is intended to make accurate and safe parallel operation with the single motor and twin hooks, which is best suited to applications where a long object or even lifting is required by using two lifting points.

Safety Precautions

DANGER



PROHIBITED

- **Disassembly, assembly, repair, and adjustment of the electric chain hoist should be performed only by maintenance personnel.**

Failure to follow this precaution may cause serious accidents leading to serious or even fatal injury.



COMPULSORY

- **This operation manual describes specific information regarding the Twin Hook Electric Chain Hoist. Before use, read and comply with both the ER2 Series Electric Chain Hoist (250kg to 5t) Owner's Manual (separate volume) and this manual.**
- **Sufficiently lubricate the load chain and idle sheave.**

Failure to follow these precautions may cause serious accidents leading to serious or even fatal injury.

Product Specifications

This twin hook electric chain hoist is designed the same as a standard hoist. Please refer to the sections of "Product Specifications" in "ER2 Series Electric Chain Hoist Owner's Manual" (separate volume).

Trolley Configurations & Name

■ TWER2M (Motorized Trolley)

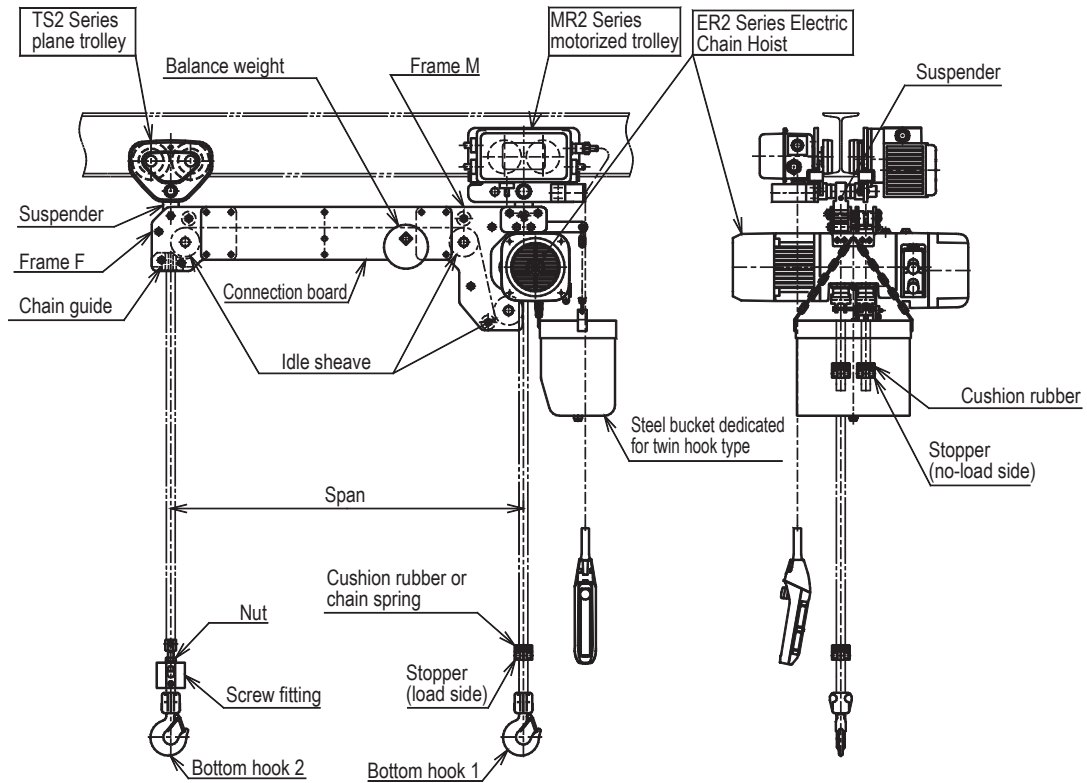

■ TWER2 (Hook suspension)

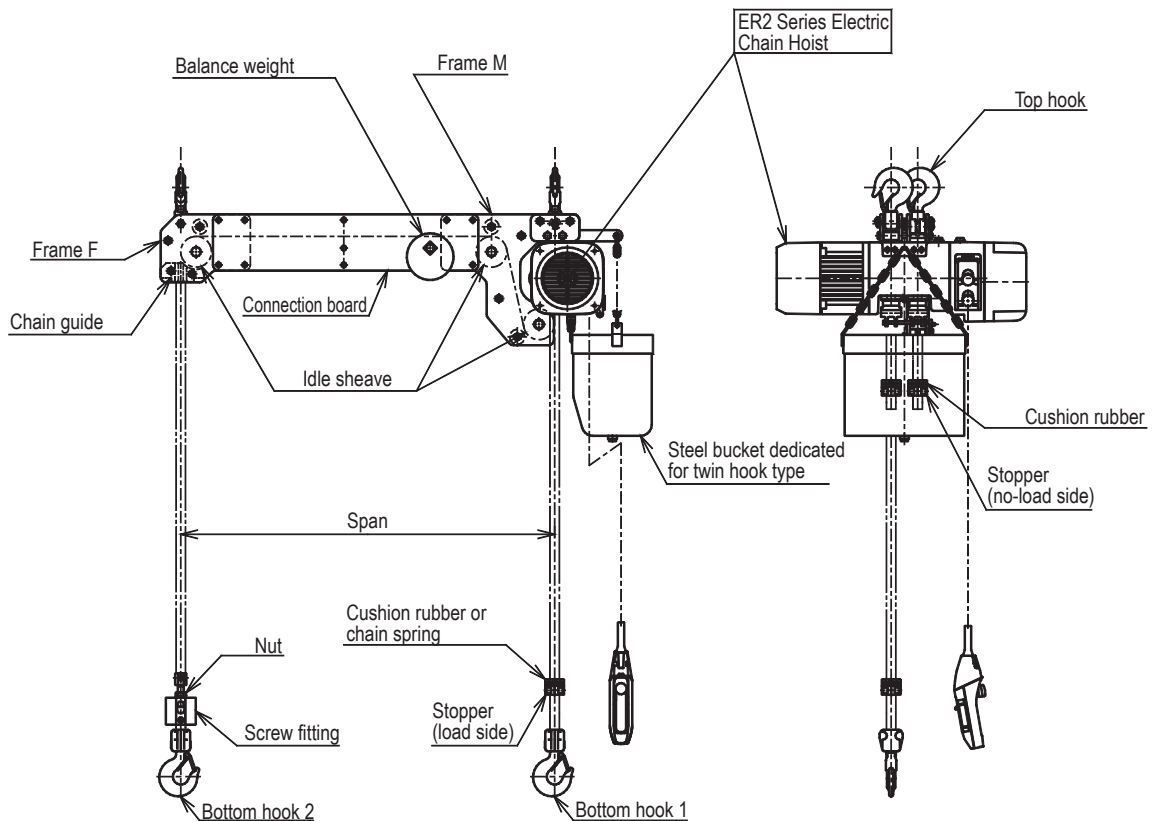

Assembly

■ Trolley Width Adjustment

The Twin Hook Electric Chain Hoist (TWER2M) was pre-adjusted at the time of shipment to the beam width of the customer on site. Depending on installation and space conditions, when it needs to disassemble and assemble the trolley upon rearrangement or maintenance of the trolley frame, please refer to the section of "Combination with the Trolley" in the ER2 Series Electric Chain Hoist (250kg to 5t) Owner's Manual (separate volume).

■ Adjusting the Height of Bottom Hook

⚠ DANGER



PROHIBITED

- Do not adjust the height of the bottom hook beyond the threaded range visible from the check hole.

Failure to follow this precaution may cause serious accidents leading to serious or even fatal injury.



COMPULSORY

- Fasten nuts with the specified torque.
- Replace with a new split pin and be sure to insert and bend it.

Failure to follow these precautions may cause serious accidents leading to serious or even fatal injury.

⚠ CAUTION



COMPULSORY

- After installation, adjust the height of the bottom hook under no load.
- It may not be possible to properly adjust the height of the bottom hook after the load chain has been replaced. In that case, be sure to contact your local sales dealer or KITO to cut and adjust the height of the bottom hook.

Failure to follow this precaution may cause serious injury or property damage.

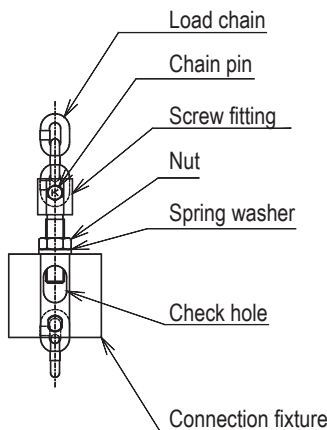

● Single-chain Type

- 1) Measure the difference between heights of bottom hook 1 and bottom hook 2 with the load suspended.
- 2) Remove the load and then loosen the nut.
- 3) Turn the screw fitting to adjust the height of the hook (within the threaded range visible from the check hole).
- 4) Fasten the nut to fix the screw fitting (Torque: M16 - 164Nm, M20 - 329Nm, M24 - 570Nm).

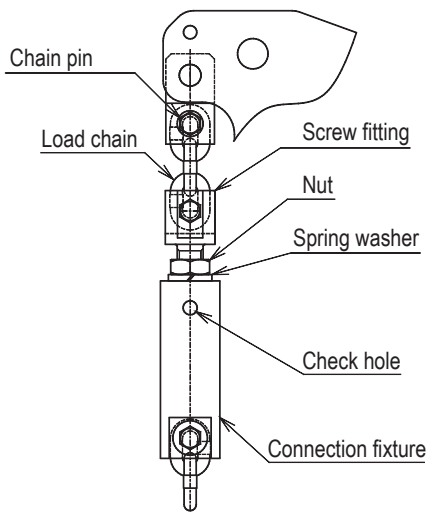

● Double-chain Type

- 1) Measure the difference between heights of bottom hook 1 and bottom hook 2 with the load suspended.
- 2) Remove the load and the chain pin.
- 3) Loosen the nut and then adjust the screw fitting by a length twice the measured within the threaded range visible from the check hole.
- 4) Fasten the nut to fix the screw fitting (Torque: M16 - 164Nm, M20 - 329Nm, M24 - 570Nm).
- 5) Make sure that the load chain is not twisted. Insert the chain pin so that its head is oriented as shown in the left picture, and insert a new split pin to fix it.

■Attaching Load Chain Accessories

The load chain is provided with a chain spring, a cushion rubber, a stopper, and a chain fixing plate in place. The variations and installation of these parts differ from each capacity.

When replacing any of these parts or the load chain, attach properly them as follows.

●Chain Accessories Variations

The accessories are installed at the specific place as shown in the following table with reference to the figures on Page 3 for single chain fall and on this page for double chain fall.

Rated load		250kg(125kg+125kg) 500kg(250kg+250kg)	1t (500kg+500kg)	2t (1t+1t)	3t(1.5t+1.5t)	5t(2.5t+2.5t)
Chain fall		Single-chain type (single chain fall)			Double-chain type (double chain fall)	
Load side	Accessory	Stopper Cushion rubber	Stopper Cushion rubber	Stopper Chain spring Limit stopper	Stopper Chain spring (2 types x 2) Limit stopper (2)	Stopper Chain spring (2 types x 2) Limit stopper (2)
	Attached position	5th link	6th link	5th link	6th link	5th link
No-load side	Accessory	Stopper Cushion rubber	Stopper Cushion rubber	Stopper Cushion rubber	Stopper Cushion rubber	Stopper Cushion rubber
	Attached position	3rd link	3rd link	3rd link	3rd link	3rd link

Double-chain type (double chain fall)

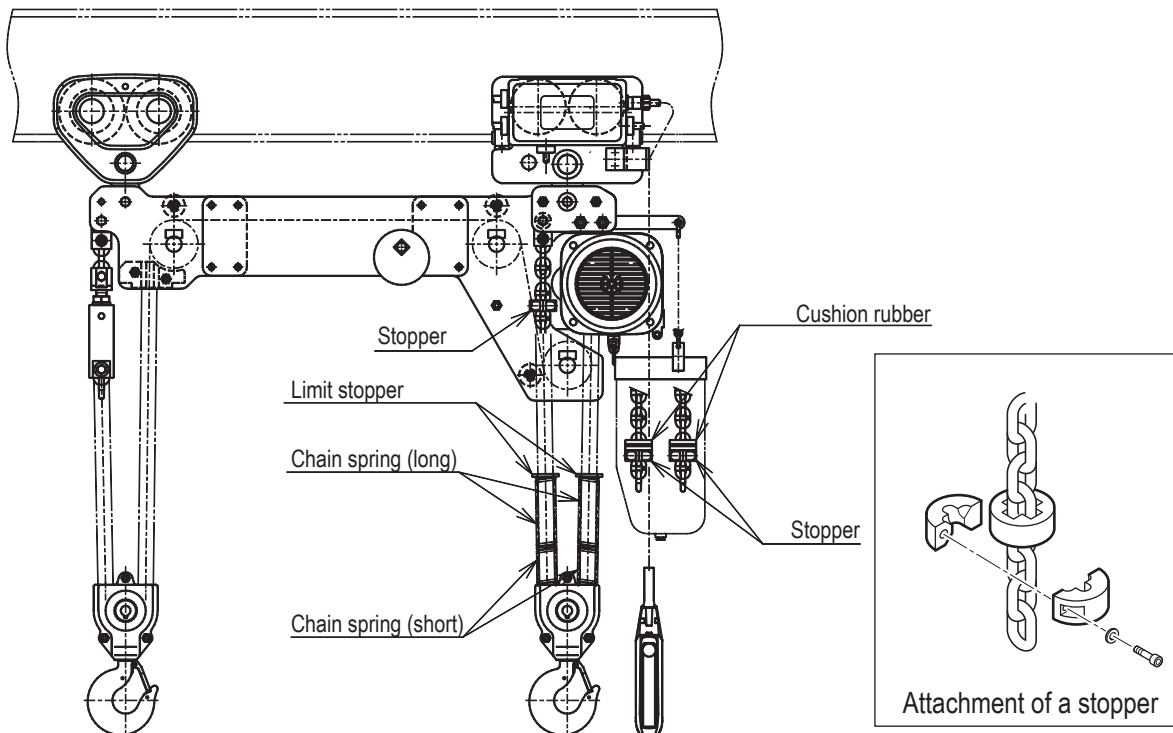

Installation

For installation of the Twin Hook Electric Chain Hoist, refer to "Installation" in the ER2 Series Electric Chain Hoist Owner's Manual (separate volume). With reference to the trolley mount, mounting the trolley at the end of the beam is the best method from the structural point of view.

DANGER



PROHIBITED

- **Installation or uninstallation should be performed only by personnel who are professional or competent.
(Consult your dealer or KITO; otherwise make a request of professional or competent personnel for installation.)**

Failure to follow this precaution may cause serious injury or property damage.

CAUTION



COMPULSORY

- **At the time of installation, make sure that the load chain properly engages with the idle sheave without being twisted or slack. In mounting the trolley onto the beam by extending the trolley width, make sure that the trolley does not derail.**

Failure to follow this precaution may cause serious injury or property damage.

Operations

This twin hook electric chain hoist is operated the same as a standard hoist. Please refer to the sections of "How to Use" in "ER2 Series Electric Chain Hoist Owner's Manual" (separate volume).

DANGER



PROHIBITED

- **Do not obliquely lift a load.**
- **Do not use the twin hooks whose heights are different.**
- **Do not lift a load only via the Bottom hook 2.**

Failure to follow these precautions may cause serious accidents leading to serious or even fatal injury.

CAUTION



COMPULSORY

- **When lifting a load only via the Bottom hook 1, reduce the load to a half of the rated load or less.**
- **Make sure that the twin hooks vertically rises in lifting a load.**
- **Use a hoist whose specifications (span) is suited for a load length.**

Failure to follow these precautions may cause serious injury or property damage.

Maintenance

■ Daily Inspection and Periodic Inspection

⚠ DANGER



COMPULSORY

- Sufficiently lubricate the load chain and idle sheave.
- Before use, make sure that the limit switch properly works in lifting under no load.

Failure to follow these precautions may cause serious accidents leading to serious or even fatal injury.

⚠ CAUTION



COMPULSORY

- Use properly the hoist in accordance with operational instructions as carrying out the daily and periodic inspections.
- Periodically lubricate the needle bearing in the idle sheave by using the grease gun through two grease nipples.

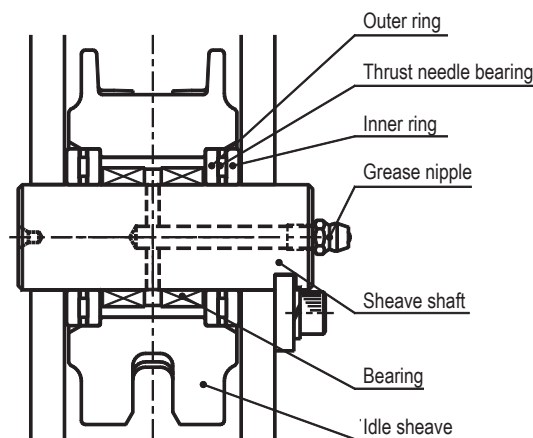

- Fasten the bolts and screws with the proper torque.

Failure to follow these precautions may cause serious injury or property damage.

In addition to the inspection items in the ER2 Series Electric Chain Hoist Owner's Manual (separate volume), please also check the Twin Hook Electric Chain Hoist on the following items for the daily and periodic inspections. With reference to "Criteria" of the inspection items in the ER2 Electric Chain Hoist (250kg to 5t) Owner's Manual, please turn to the points for the same capacity as that (total capacity) of Twin Hook Electric Chain Hoist.

Twin Hook Electric Chain Hoist Inspection Items

Items	Inspection period		Inspection method	Criteria	When failed
	Daily	Periodic			
Appearance	<input type="radio"/>	<input type="radio"/>	- Visual check	- There is no damage, deformation, or remarkable corrosion. - The unit is not tilted (the balance weight is attached).	Replace damaged parts. Attach the balance weight.
Limit switch	<input type="radio"/>	<input type="radio"/>	- Check the operation with no load.	- Make sure that the hook stops at the upper-limit and can be lowered.	Contact your dealer.
Position of bottom hook	<input type="radio"/>	<input type="radio"/>	- Visual check	- Even and accurate in position	Adjust the height.
Bolts and nuts for frame F/M	<input type="radio"/>	<input type="radio"/>	- Visual check	- There is no loose or dropped-out bolt or nut.	Fasten securely.
Each hole of frame F/M		<input type="radio"/>	- Measurement using a slide caliper	- The amount of wear is 5% or less (the difference between vertical and horizontal diameters of each hole is 5% or less).	Replace damaged parts.
Chain guide		<input type="radio"/>	- Visual check	- There is no remarkable damage, deformation, or wear.	Replace damaged parts.
Nut for screw fitting	<input type="radio"/>	<input type="radio"/>	- Visual check	- There is no loose or dropped-out nut. - The screw section can be checked from the check hole.	Fasten securely.
Suspender		<input type="radio"/>	- Measure the hole diameter using a slide caliper.	- The amount of wear is 5% or less (the difference between vertical and horizontal diameters of each hole is 5% or less).	Replace damaged parts.
Idle sheave	<input type="radio"/>	<input type="radio"/>	- Visual check - Daily inspection: Operation with no load - Periodic inspection: Operation with a rated load	- Sufficiently lubricate. - Smoothly rotating without irregular sound.	Lubricate through the grease nipple. Replace damaged parts.

< Memo >

A series of horizontal dotted lines for writing.

< Memo >

A series of horizontal dotted lines for writing.

< Memo >

A series of horizontal dotted lines for writing.

KITO

Global Website: kito.com