

EQ Series Electric Chain Hoist (125kg to 1t)

Owner's Manual

Suspended Type (hoist only) : EQ
Motorized Trolley Type : EQM
Manual Trolley Type : EQSP

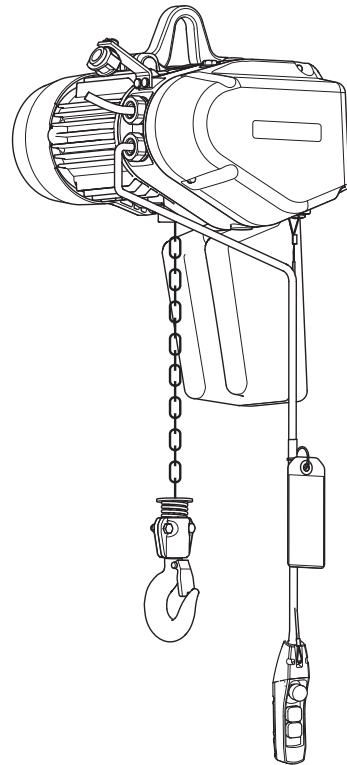

To Customer

- Thank you for purchasing KITO Electric Hoist (EQ).
- Operators and maintenance engineers are requested to read this manual.
After reading, please keep this manual at hand for future use.
- This product is designed considering the environment protection. The product contains none of six hazardous substances specified by European RoHS Directives nor asbestos.

Table of Contents

Introduction	2
Safety Precautions	4
Chapter 1 Handling the Product	7
Chapter 2 Inspection	59
Chapter 3 Troubleshooting	91
Appendix	111
Warranty	124

Introduction

This electric hoist EQ is designed and manufactured for the purpose to lift and lower a load within a normal work environment. The motorized trolley MR2Q and the manual trolley are designed and manufactured for the purpose to move the lifted load laterally with the combination with the electric hoist.

Movement of a load in a 3D direction such as up/down, forward/backward and right/left is also enabled by combining with a crane.

This Owner's Manual is intended for those operating the KITO electric hoist EQ and maintenance engineers (* personnel with expertise).

Other than this manual, Disassembly/Reassembly Manual is also available for the maintenance engineers. Assign the maintenance engineers and use these materials for inspection and repair. Please contact the nearest distributor or KITO for these materials.

* A person who has a thorough knowledge of the structure and rolls concerning Electric chain block and is recognized as an expert by an entity.

■ Disclaimer

- KITO shall not be liable for any damage incurred thereof due to natural disaster such as fire, earth quake and thunderbolt, conduct by third party, accident, willful conduct or negligence by customer, erroneous use and other use exceeding the operational condition.
- KITO shall not be liable for any incidental damage due to the use or non-use of the product such as the loss of business profit, suspension of business and damage of the lifted load.
- KITO shall not be liable for any damage arising from negligence of the contents in the Owner's Manual and the use of the product exceeding the scope of its specification.
- KITO shall not be liable for any damage arising from the malfunction due to the combination of the product with other devices in which KITO is not concerned.
- KITO shall not be liable to supply the spare parts for the product for which it has passed for 15 years since the discontinue of the product.

■ Restriction on Use

- The product described herein is not designed or manufactured for transporting people. Do not use the product for that purpose.
- The product described herein is designed for the materials handling work such as lifting/lowering and traveling the load under ordinary operational condition. Do not use the product for the work other than materials handling work.
- Do not assemble the product into machinery not for materials handling, as a part of it.

■ Operators

- Read carefully this Owner's Manual and the instruction manuals of related products, fully understand their contents, and the use and operate the product.
- Be sure to wear the proper clothing and protective equipment when using and operating the product.

■ Laws and Standards

Carry out installation, inspections, operations, maintenance management in accordance with the laws and standards of the country and region where the product is used.

An application before installation or a test before beginning usage may be required. Furthermore, the tester may be required to have specific qualifications. Be sure to check the laws and standards of the corresponding country and region before using the product.

Safety Precautions

Improper use of electric chain hoist causes danger such as drop of lifted load. Read this Owner's Manual carefully before installation, operation and maintenance. Use the product after understanding the product knowledge, safety information and precautions.

This Owner's Manual classifies the safety information and precautions into three categories of "DANGER" "WARNING" and "CAUTION".

Also read the instruction manual of the device associated with electric chain hoist, and follow the described contents.

Description of Signal Words



DANGER

Indicates an imminently hazardous situation which, if not avoided, will result in death or serious injury.



WARNING

Indicates a potentially hazardous situation which, if not avoided, could result in death or serious injury.



CAUTION

Indicates a potentially hazardous situation which, if not avoided, may result in minor or moderate injury. It may also be used to alert against unsafe practices.

Further, the event described in CAUTION may result in serious accident depending on the situation. All three categories describe important contents. Please follow the instruction.

After reading, please keep this manual at hand for future use by the user.

Description of Safety Symbols



Prohibited

Means "Prohibited" or "You must not do".

Prohibited action is shown in the circle or described near the circle.

This Owner's Manual uses  as the general prohibition.



Mandatory

Means "Mandatory Action" or "You must do".

Required action is shown in the circle or described near the circle.

This Owner's Manual uses  as the general instruction.

General Matters on Handling and Control



DANGER



Prohibited

- **This product shall not be disassembled and repaired by personnel other than maintenance engineers.**

Other than this manual, Disassembly/Assembly Manual and Parts List are provided for the maintenance engineers. Perform the disassembling and repair by the maintenance engineer in accordance with these materials for maintenance.

- **Do not modify the product and its accessories.**

Failure to comply with these instructions may result in death or serious injury.



Mandatory

- **Understand the contents of the Owner's Manual sufficiently. Then operate the Electric chain hoist.**
- **Warning label is affixed to each part of the product. Follow the instruction described in the warning label.**

Failure to comply with these instructions may result in death or serious injury.

CAUTION



Prohibited

- **Do not drag or drop the product when carrying.**

Otherwise it causes damage or flaw of the electric chain hoist, bodily injury or loss of property due to the drop of the lifted load.



Mandatory

- **When discarding the product, disassemble it not to be used and discard in accordance with the ordinances of local government or the rules specified by the business entity.**

Ask the local government or the relevant section for the details.

Refer to "Disassembly/Assembly Manual" for disassembling, or contact KITO.

(This product uses oil. We prepare MSDS (Materials Safety Data Sheet) for the oil. Contact KITO for it.)

- **Carry out daily inspection by user.**
- **Carry out inspection (monthly, annual) by maintenance engineer.**
- **Keep the record of the inspection.**

Failure to comply with these instructions causes bodily injury or loss of property.

■ General Matters on Handling of EQ Series Electric Chain Hoist

The EQ series electric chain hoist is controlled by VFD for important items related to safety such as operation, braking and emergency stop. Be sure to follow the safety precautions below as well as the above safety precautions.

DANGER



Prohibited

- **Do not reassemble the EQ series electric chain hoist to contactor type.**
- **Do not change parameters.**

When parameters need to be changed, ask distributor or KITO.

- **Do not carry out the work such as maintenance and inspection within 5 minutes after power off.**

Wait for the completion of discharging of the capacitor inside the VFD.

- **Do not change the connection of the VFD.**

When the wires were removed for any reason, connect them again correctly checking the wiring diagram inside the controller cover.

- **Do not carry out withstand voltage test and insulation resistance measurement of a circuit by megger while the VFD is connected.**

- **Do not turn off the power while operating.**

- **Never turn off the power when a load is suspended.**

Never, under any circumstances, turn off the power when a load is suspended. Doing so will cause the load to be slightly lowered after the power is turned on again due to control system initial preparation.

Failure to comply with these instructions may result in death or serious injury and the damage of VFD.



Mandatory

- **USE KITO genuine VFD.**

The VFD requires the special specification for KITO. Be sure to use genuine VFD.

Failure to comply with this instruction may result in death or serious injury.

Chapter 1

Handling the Product

This chapter describes mainly how to use, assemble and install, and the check after installation. It also describes the daily inspection items before use.

Type and Names of Each Part	8
Opening the Package	11
Product Specification and Operational Environment	16
How to Use	18
• Daily Inspection of Electric Chain Hoist (EQ)	19
• Daily Inspection of Motorized Trolley (EQM).....	24
• Daily Inspection of Manual Trolley (EQSP)	25
• How to Operate the Push Button Switches.....	26
• Operation.....	29
• Speed Change of Dual Speed for EQ Model	32
• How to Sling the Load Properly	32
• How to Suppress the Swinging of a Load	32
• Precautions After Work	33
Work Flow of Assembling and Installation.....	34
Assembling	35
Assembling Parts to Electric Chain Hoist.....	35
• Combination with the Trolley.....	38
• Checking Power and Power Cable.....	48
• Connecting Cables	50
Installation.....	53
• Connecting Power and Power cable.....	53
• Installing the Suspended Type (hoist only).....	53
• Installing the Trolley Combined Model.....	54
Check after Installation	57

Type and Names of Each Part

■ Suspended Type (EQ)

- Electric chain hoist dedicated for elevation

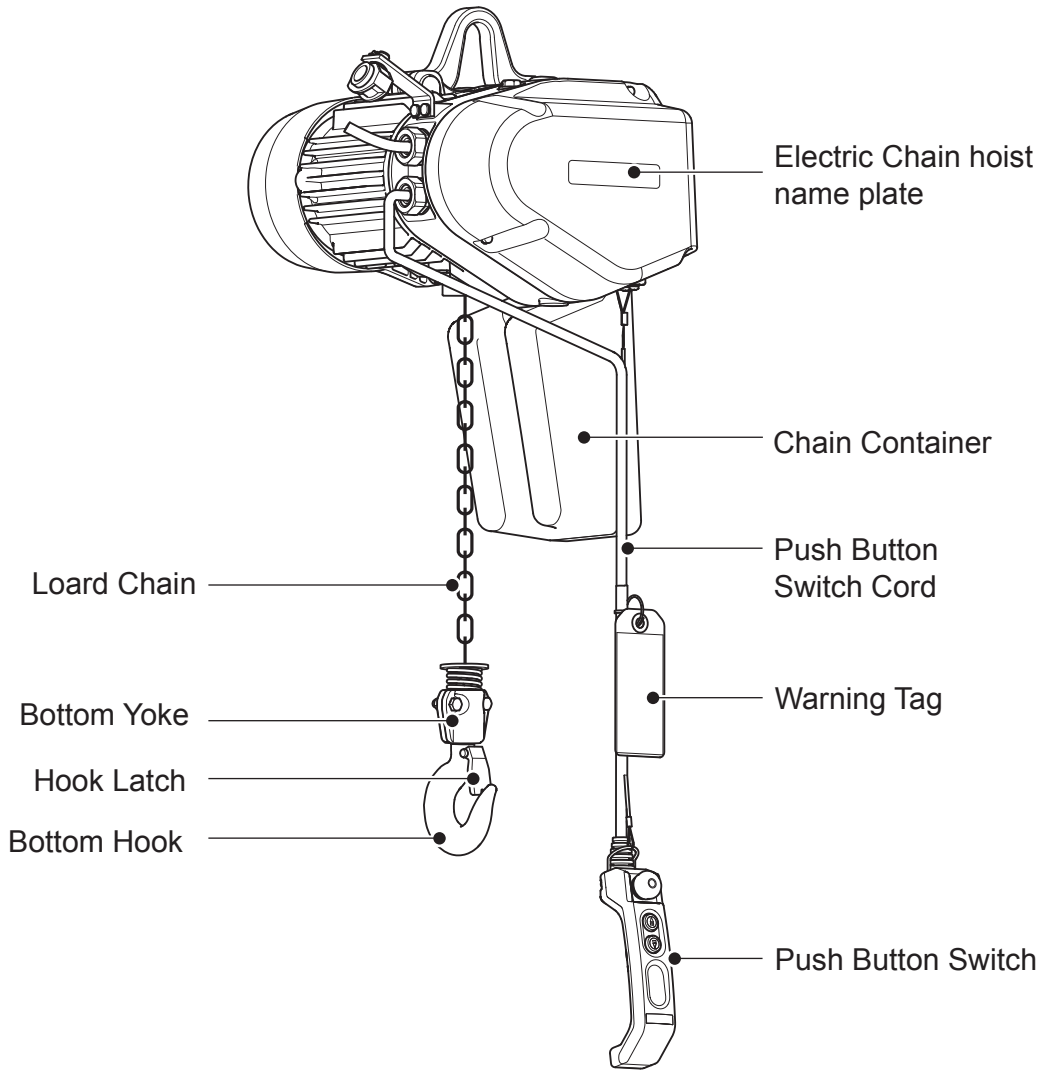

DANGER



Mandatory

- Warning labels are affixed to each part other than above. Be sure to follow the instructions in the label. Failure to comply with the contents of the label may result in death or serious injury.

■ Motorized Trolley Type (EQM)

- Electric Chain Hoist combined with motorized trolley (MR2Q) for elevation and traveling motion

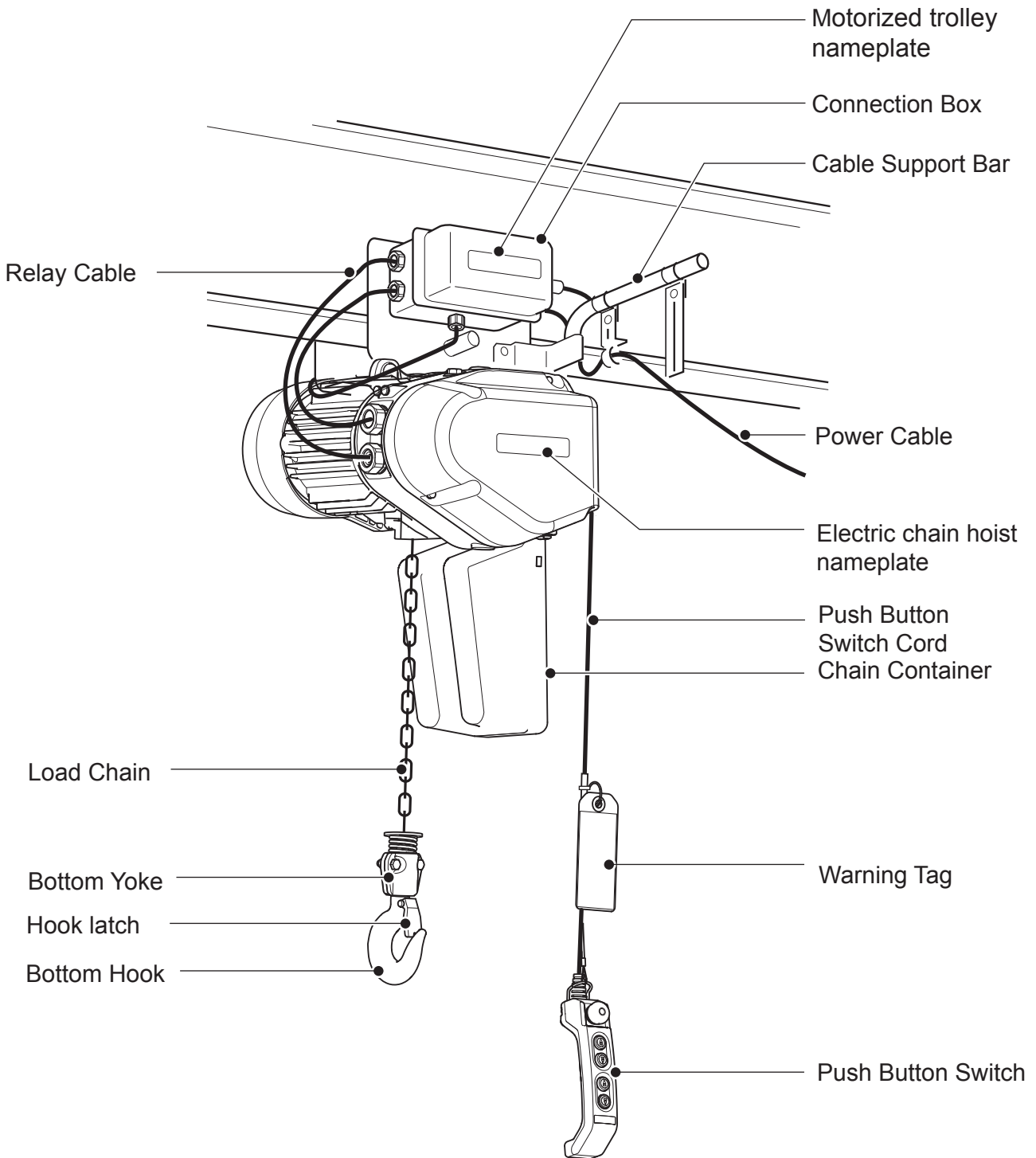

⚠ DANGER



Mandatory

- **Warning labels are affixed to each part other than above. Be sure to follow the instructions in the label.**
Failure to comply with the contents of the label can result in serious bodily injury or death.

(to be continued)

Type and Names of Each Part (continued)

Manual Trolley Type (EQSP)

- The electric chain hoist equipped with the plain trolley (TSP) enabling lateral motion by moving the load manually. For light work.

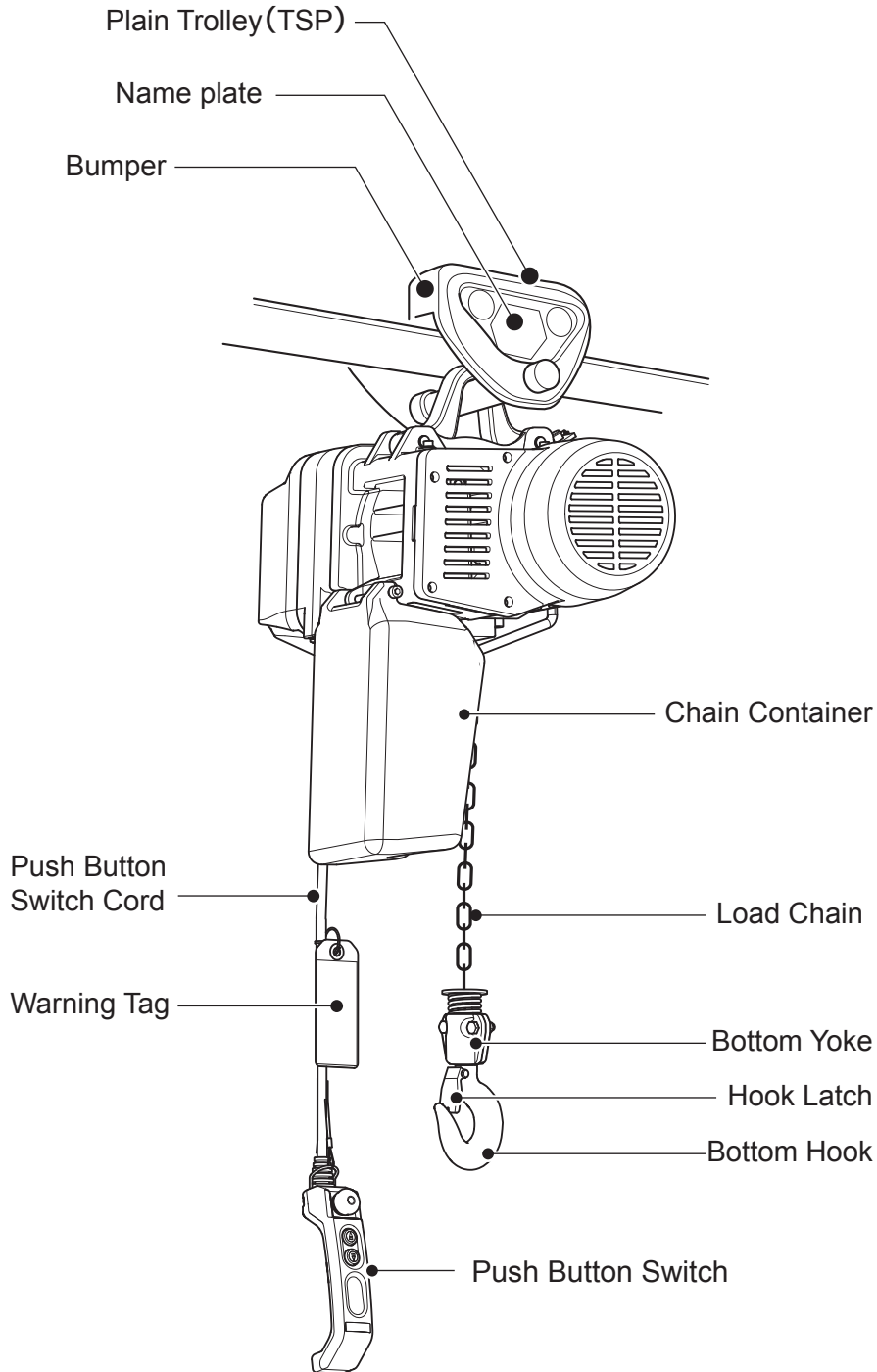

⚠ DANGER



Mandatory

- **Warning labels are affixed to each part other than above. Be sure to follow the instructions in the label.**
Failure to comply with the contents of the label can result in serious bodily injury or death.

Opening the Package

■ Checking the Product

- Make sure that the indication on the package and the product coincide with your order.
- Make sure that the product is not deformed and damaged due to the accident during transportation.

■ Parts packaged with the Electric Chain Hoist

Plastic or canvas Chain Container

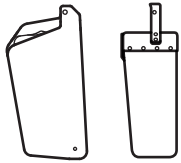

Manual

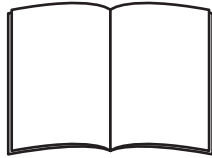

Load Chain Grease Tube



Thick Spacer L (for manual trolley) 2 pieces



Opening the Package (continued)

■ Nameplate and Product Model

■ Nameplate Indication of Electric Chain Hoist

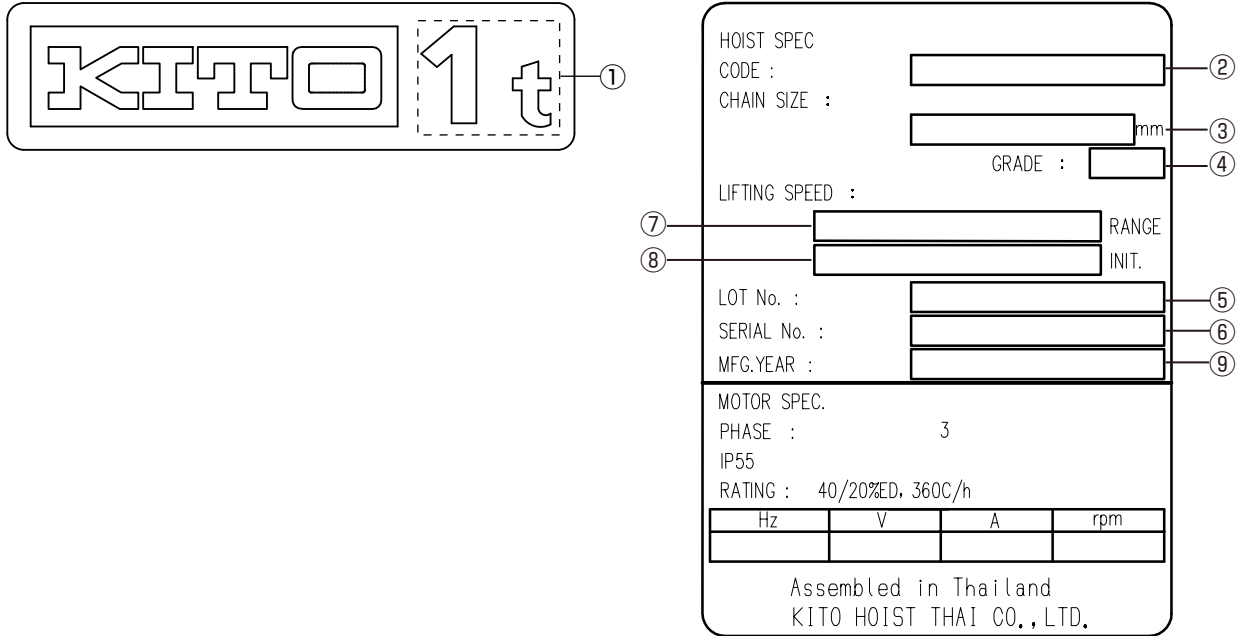

- ① ... Capacity Ex. 1 t
The maximum mass of the load that can be imposed on the product. The mass of the hook is excluded.
- ② CODE...Product model Ex. EQ010IS
A code to indicate the model No. of the product, capacity and lifting speed.
- ③ CHAIN SIZE...Load Chain size
Ex. DAT-7.1×19.9mm
The alphabet and the figures indicate the JIS grade, wire diameter and chain pitch respectively.
- ④ GRADE(FEM)...Ex. M5
The grade of an electric chain hoist specified by ISO standard. A guidepost of durability.
- ⑤ LOT No.
Manufacture No. to identify the time of manufacture and the quantity of a production unit.
Ex. EQ1 -XXXXXXXX
 ↑ A,B...
- ⑥ SERIAL No.
Serial No. to indicate the manufacturing sequence of the product.
- ⑦ Changeable range of the lifting speed
- ⑧ Initial setting value of the lifting speed
- ⑨ MFG. YEAR...Manufacture year

■ Code of EQ

Capacity	Body Size	CODE
125kg	EQ-C	EQ001IS
250kg		EQ003IS
490kg		EQ004IS
500kg		EQ005IS
1t	EQ-D	EQ010IS

■ Nameplate Indication of Motorized Trolley

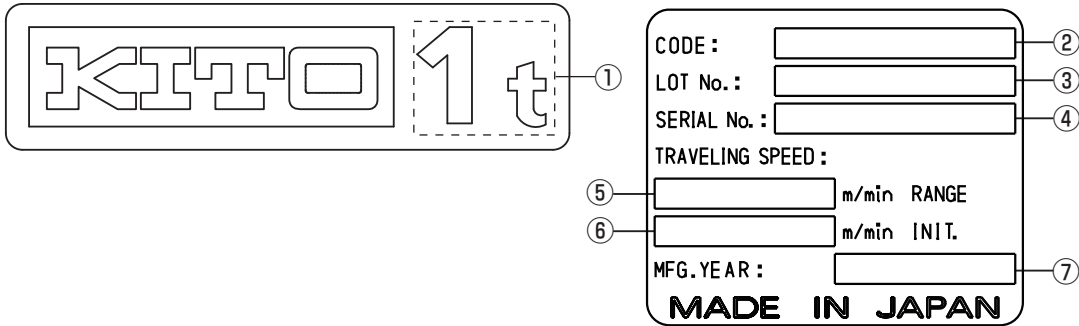

- ① 1 t ··· Capacity Ex. 1 t
The maximum mass of the load that can be imposed on the product. The mass of the hook is excluded.
- ② CODE ··· Product model Ex. MR2Q010IS
Indicates the model No. of the product, capacity and lifting speed of the product.
- ③ LOT No.
Manufacture No. to identify the time of manufacture and the quantity of a production unit.
- ④ SERIAL No.
Serial No. to indicate the manufacturing sequence of the product.
- ⑤ Changeable range the traveling speed.
- ⑥ Initial setting value of the traveling speed.
- ⑦ MFG. YEAR...Manufacture year

■ Code of MR2Q

Capacity	CODE	
	Model MR2Q dual speed VFD model	
	Standard speed	
125kg 250kg 490kg 500kg 1t	MR2Q010IS	

Opening the Package (continued)

■ Nameplate Indication of Manual Trolley

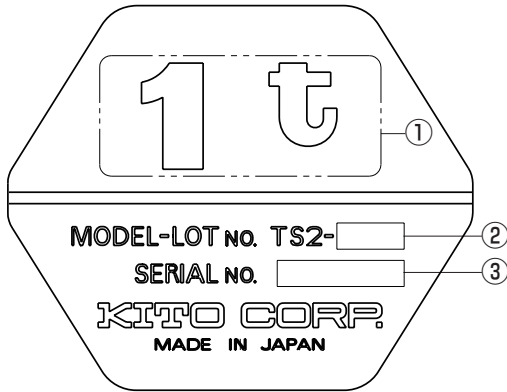

- ① ... Capacity Ex. 1 t
The maximum mass of the load that can be imposed on the product.
The mass of the hook is excluded.
- ② LOT No.
Manufacture No. to identify the time of manufacture and the production lot.
- ③ SERIAL No.
Serial number to indicate the manufacturing sequence of the product.

■ Checking the Marks

⚠ DANGER



Mandatory

- Be sure to check that the Load Chain has "FT-DAT" mark on it and the chain size is appropriate for the EQ model you are using. (See the following table.) The Load Chain of other models (such as model ES or ER) or different rating cannot be used.

Use of the Load Chain of other model or other rating may result in death or serious injury due to the drop of the lifted load.

Code of EQ	Load Chain size : diameter (mm)	Mark pitch
EQ001IS	5.6	20 Links
EQ003IS		
EQ005IS		
EQ010IS	7.1	20 Links

The mark (FT-DAT) to indicate the model of the Load Chain is indicated on it at an equal spacing. Make sure that the Load Chain is of a chain size (wire diameter) appropriate for EQ referring to the table in the left.

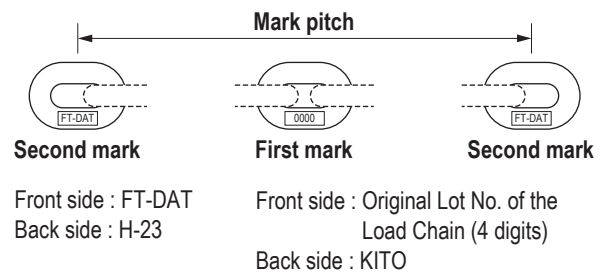

■ Recording the Product No.

- Fill in the table in the right with product's Lot No., Serial No. (described in the product nameplate), date of purchase and the name of the sales shop where you purchased the product.
- * When requesting repair or ordering a chain hoist part, please inform us of these pieces of information together.

Item	Electric chain hoist	Motorized trolley	Manual trolley
Lot No.	EQ-	MR2Q-	TS2-
Serial No.			
Date of purchase			
Name of the sales shop			

■ Recording the Initial Value

- When opening the package, fill in the table in the right with the opening dimension "a" between embossed marks on the Bottom Hook, the width of the hook "b", the thickness of the hook "c", the thickness of the Suspension Eye "d", and the width "e". (These values are used for checking. See P64 for the inspection criteria.)

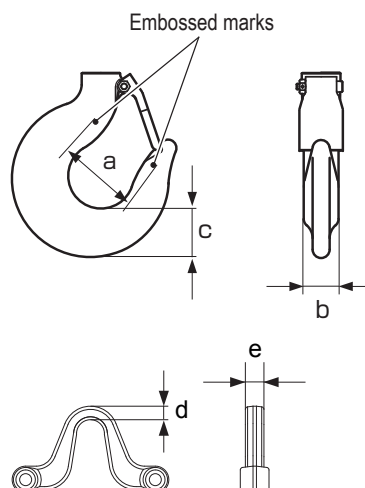

Dimensions when the package was opened

	Dimension	mm
Bottom Hook	Dimension a	mm
	Dimension b	mm
	Dimension c	mm
Suspension Eye	Dimension d	mm
	Dimension e	mm

Product Specification and Operational Environment

The operational environment of the electric chain hoist and motorized trolley is as follows:

■ Standard Specification

- Intermittent ratings :EQ series (100 % of the capacity): Dual speed VFD model (high speed/low speed) — 40/20 % ED (120/240 rev/h)
:MR2Q series (100 % of the capacity): Dual speed VFD model (high speed/low speed) — 27/13 % ED (78/162 rev/h)
- Grade * 1 :ISO-M5 or M4, FEM-2 or ASME-H4
- Protection :Hoist IP55, Push button IP65
- Operation.....Push button switch operation / 3-Push Button Switch set for hoist only and Manual trolley type / 5- or 7-Push Button Switch set for motorized trolley combined model
- Power supply method.....Power supply through cabtyre cable
- Color.....Body: KITO Metallic gray, Controller Cover and Fan Cover: KITO Yellow (Equivalent to Munsell 7.2 YR 6.5/14.5)
- Noise level :EQ, dual speed VFD model 80dB or less (A scale: measured at 1 m away from the Electric chain hoist)
:MR2Q 85dB or less (A scale: measured at 1 m away from the Electric chain hoist)
- Braking capacity :150% of the capacity or more
- Other.....Power Cable length 5 m/10 m (Standard)
- Sound power level :MR2Q 96db or less (A scale)

Product category	Motor Insulation Class	Voltage range		Operating Voltage
		50Hz	60Hz	
230V Class	B	220V	220V	DC24V
		230V	230V	
400V Class		380V	380V	
		400V	440V	
		415V	—	

NOTE

- Operate the electric chain hoist with the rated voltage.
- Do not use the electric chain hoist exceeding the intermittent ratings.

* Grade 1

Capacity	Code	GRADE		
		ISO	ASME	FEM
	Dual speed	Dual speed	Dual speed	Dual speed
125kg	EQ001IS	M6	H4	3m
250kg	EQ003IS			
490kg	EQ004IS			
500kg	EQ005IS			
1t	EQ010IS	M5	H4	2m

ISO

Loading status	Total operating hour h					
	800	1600	3200	6300	12500	25000
Light	—	—	—	—	M5	M6
Medium	—	—	—	M5	M6	—
Heavy	—	—	M5	M6	—	—
Ultra heavy	—	M5	M6	—	—	—

* Rate of loading

- Light : A case where the capacity is rarely applied. Usually the hoist is used with a light load.
- Medium : A case where the capacity is applied considerably frequently. Usually the hoist is used with a medium load.
- Heavy : A case where the capacity is applied considerably frequently. Usually the hoist is used with a heavy load.
- Ultra heavy : A case where the capacity is applied constantly.

• ASME HST

Hoist duty class	Typical areas of application	Operation time ratings at K=0.65			
		Uniformly distributed work periods		Infrequent work periods	
		Max. on time, min / hr	Max. No. starts / hr	Max. on time from cold start, min	Max. No. of starts
H2	Light machine shop fabricating, service, and maintenance; loads and utilization randomly distributed; capacity infrequently handled.	7.6 (12.5%)	75	15	100
H3	General machine shop fabricating, assembly, storage, and warehousing; loads and utilization randomly distributed.	15 (25%)	150	30	200
H4	High volume handling in steel warehouses, machine shops, fabricating plants and mills, and foundries; manual or automatic cycling operations in heat treating and plating; loads at or near capacity frequently handled.	30 (50%)	300	30	300

FEM

Comparison of ISO rating and FEM rating

1 Dm	1 Cm	1 Bm	1 Am	2 m	3 m	4 m	5 m
M1	M2	M3	M4	M5	M6	M7	M8

Condition of the load	Rate of loading	Rating of the operating hours									
		V0.06	V0.02	V0.25	V0.5	V1	V2	V3	V4	V5	
		T0	T1	T2	T3	T4	T5	T6	T7	T8	
		Average operating hours per day (hour)									
		≤0.12	≤0.25	≤0.5	≤1	≤2	≤4	≤8	≤16	>16	
1 L1	K≤0.50	-	-	1Dm	1Cm	1Bm	1Am	2m	3m	4m	
2 L2	0.50<K≤0.50	-	1Dm	1Cm	1Bm	1Am	2m	3m	4m	5m	
3 L3	0.63<K≤0.80	1Dm	1Cm	1Bm	1Am	2m	3m	4m	5m	-	
4 L4	0.80<K≤1.00	1Cm	1Bm	1Am	2m	3m	4m	5m	-	-	

Rating code is FEM9.551
(Design rules of hoisting equipment for every series: classification rating of internal structure)

Rating of the operating hours	Average operating hours per day (hour)	Total operating hours
V0.06 T0	≤0.12	200
V0.12 T1	≤0.25	400
V0.25 T2	≤0.5	800
V0.5 T3	≤1	1,600
V1 T4	≤2	3,200
V2 T5	≤4	6,300
V3 T6	≤8	12,500
V4 T7	≤16	25,000
V5 T8	>16	50,000

Operational Environment

- Ambient temperature : -20°C — +40°C
- Gradient of rail : No gradient in travel rail (for the hoist with trolley)
- Ambient humidity : 85 % or less (no condensation)
- Explosion-proof construction : Not applicable to the work environment with explosive gases or explosive vapor
- Non-conforming environment : A place with organic solvent or volatile powder, and a place with a plenty of powder and dust of general substances
- : A place with considerable amount of acids and salts

NOTE

As a general rule, use the product indoors. When installing the electric chain hoist outdoors or to the place where the hoist is exposed to direct rain, wind and snow, shade the hoist with roof to protect it from rain, wind and snow.

How to Use

KITO Model EQ Electric Chain Hoist is a dual speed VFD model. Other than them, such products are provided that can travel/traverse when combined with a trolley or a crane. Their push button switches for operation differ in the size and the operating method. Check the product model of the hoist and use it properly.

DANGER



Prohibited

- Do not use the Hook without a Hook Latch or damaged Hook.
- Do not use the Load Chain with heavy elongation, abrasion or deformation.
- Do not cut, extend, or weld the Load Chain.
- Do not use the Load Chain with the Bottom Hook without smooth motion.
- Do not use the Load Chain when its brake does not function securely even without load, or when the stopping distance is too long.
- Do not use the product if it moves oppositely to the direction indicated on the push button switch.

Failure to comply with these instructions may result in death or serious injury.



Mandatory

- Carry out daily inspection before operation.
(When any abnormality was found during inspection, turn off the power, indicate "FAILURE" and ask the maintenance engineer for repair.)
- Check the slinging devices for no abnormality.
- The diameter of the Suspension Shaft hooked by Suspension Eye should be thinner than 31mm or less.
Failure to comply with these instructions may result in death or serious injury.

CAUTION



Prohibited

- Do not use the product with an illegible nameplate or warning label affixed to the body size.

Failure to this instruction may result in the injury or the property damage.



Mandatory

- When using the product for the first time, affix the labels indicating East, West, North and South on the push button switches.
- Check the contents of the work and make sure that the electric chain hoist has proper performance for the load and lift.
- Check the contents of the work and operate the electric chain hoist at a place enabling to look out the operating area without hindrance.
- When looking out the operating area is difficult, arrange the monitor near the place for safety.
- Operate the electric chain hoist at a place with firm foothold without danger of falling, stumbling, slipping or over turning.
- Before moving the load, warn all the surrounding people.
- Even if the crane or the electric chain hoist is permanently installed and used for the same purpose repeatedly, check the contents of the work and make sure that the work does not exceed the capacity on each occasion.
- Appoint the maintenance engineer or competent personnel among the qualified personnel for operation of cranes and electric chain hoists. Indicate the name of the personnel on a place with legibility.
- The maintenance engineers shall check the result of daily inspection.
- When informed of abnormality of the electric chain hoist, the maintenance engineers shall take immediately any necessary measures such as prohibition of use and repair.
- When carrying out inspection and repair, secure the environment for safe work without electric shock and falling.

Failure to comply with these instructions may result in bodily injury or property damage.

■ Daily Inspection of Electric Chain Hoist (EQ)

DANGER	
 Mandatory	<ul style="list-style-type: none"> Carry out daily inspection before use. (When any abnormality was found during inspection, turn off the power, indicate "FAILURE" and ask the maintenance engineer for repair.) <p>Neglecting to carry out daily inspection may result in death or serious injury.</p>

■ Appearance



Item	Check method	Criteria	When failed				
Indication of Nameplates and Labels	<ul style="list-style-type: none"> Check visually. 	<ul style="list-style-type: none"> No peel off. Indication can be seen clearly. 	Carry out cleaning, repair or replace with new nameplate or label. When replacing with a new nameplate or label is required, please inform KITO of the description in "Recording of the Product No." (P15) such as Lot No. and Serial No.				
Deformation and damage of main unit and each part	<ul style="list-style-type: none"> Check visually. <div style="text-align: center;"> </div>	<ul style="list-style-type: none"> No apparent deformation, damage, flaw and crack 	Replace the parts with deformation, damage, flaw or crack.				
Loosened or fallen off bolts, nuts and split pins	<ul style="list-style-type: none"> Check visually or using tools. 	<ul style="list-style-type: none"> Bolts, nuts and split pins are fastened securely. <div style="border: 1px solid black; padding: 5px; margin-top: 10px;"> <table style="width: 100%; border-collapse: collapse;"> <tr style="background-color: #cccccc;"> <th colspan="2" style="text-align: center; padding: 2px;"> DANGER </th> </tr> <tr> <td style="width: 15%; text-align: center; vertical-align: middle;"> Mandatory </td> <td style="padding: 2px;"> <ul style="list-style-type: none"> Even fallen off of a bolt causes for the body size to drop. Be sure to check. <p>Fallen off of a bolt may result in death or serious injury.</p> </td> </tr> </table> </div>	DANGER		 Mandatory	<ul style="list-style-type: none"> Even fallen off of a bolt causes for the body size to drop. Be sure to check. <p>Fallen off of a bolt may result in death or serious injury.</p>	Fasten bolts, nuts and split pins securely.
DANGER							
 Mandatory	<ul style="list-style-type: none"> Even fallen off of a bolt causes for the body size to drop. Be sure to check. <p>Fallen off of a bolt may result in death or serious injury.</p>						

How to use (continued)

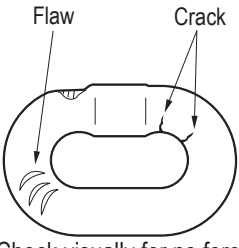
■ Load Chain

Item	Check method	Criteria	When failed
Elongation of Pitch	<ul style="list-style-type: none"> • Check visually 	<ul style="list-style-type: none"> • No apparent elongation 	Refer to Load Chain (P65) of Chapter 2, Frequent inspection.
Abrasion of Wire Diameter	<ul style="list-style-type: none"> • Check visually 	<ul style="list-style-type: none"> • No apparent abrasion 	Refer to Load Chain (P65) of Chapter 2, Frequent inspection.
Deformation, Flaw, Entanglement	<ul style="list-style-type: none"> • Check visually  <ul style="list-style-type: none"> • Check visually for no foreign matter such as attached sputter. 	<ul style="list-style-type: none"> • No deep notch • No deformation such as twist • No attached sputter • No entanglement • No crack 	Replace the Load Chain.
Rust, Corrosion	<ul style="list-style-type: none"> • Check visually 	<ul style="list-style-type: none"> • No apparent rust and corrosion 	Replace the Load Chain.
Lubrication	<ul style="list-style-type: none"> • Check visually 	<ul style="list-style-type: none"> • To be oiled adequately 	Apply oil.
Mark	<ul style="list-style-type: none"> • Check visually 	<ul style="list-style-type: none"> • Check the mark pitch and the indication. (Refer to "Checking the Marks" (P15).) 	Replace the Load Chain.

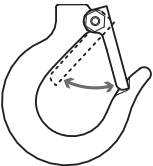
■ Suspension Eye, Bottom Hook

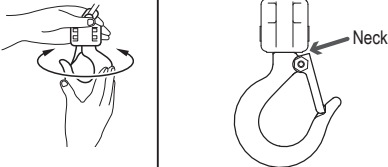
Item	Check method	Criteria	When failed
Opening of the Hook	<ul style="list-style-type: none"> Check visually 	<ul style="list-style-type: none"> No apparent opening of the Hook 	Carry out the inspection item of Suspension Eye and Bottom Hook (P66) of Frequent inspection.
Abrasion	<ul style="list-style-type: none"> Check visually 	<ul style="list-style-type: none"> No apparent abrasion 	Carry out the inspection item of Suspension Eye and Bottom Hook (P66) of Frequent inspection.
Deformation, Flaw, Corrosion	<ul style="list-style-type: none"> Check visually 	<ul style="list-style-type: none"> No apparent deformation, flaw and corrosion 	Carry out the inspection item of Suspension Eye and Bottom Hook (P66) of Frequent inspection.
Hook Latch 	<ul style="list-style-type: none"> Check visually and check the movement of the Hook Latch. 	<ul style="list-style-type: none"> The Hook Latch is mounted securely inside the Hook opening. No deformation. The Hook Latch moves smoothly. <div style="border: 1px solid black; padding: 5px; margin-top: 10px;"> <p style="text-align: center;">⚠ DANGER</p> <div style="display: flex; align-items: center;">  <div style="margin-left: 10px;"> <ul style="list-style-type: none"> Do not use the Hook without the Hook Latch. <p>Use of the Hook without the Hook Latch may result in death or serious injury.</p> </div> </div> </div>	Replace the Hook Latch.
Hook movement (Rotation) 	<ul style="list-style-type: none"> Check visually and rotate the Hook by hand. 	<ul style="list-style-type: none"> No apparent gap between the Bottom Yoke and the shank (at the neck). The Bottom Yoke rotates in both directions equally. The Bottom Yoke rotates smoothly. 	Replace the Hook.
Bottom Yoke	<ul style="list-style-type: none"> Check visually 	<ul style="list-style-type: none"> No loosened bolt or nut 	Attach the Bottom Hook to the Load Chain securely.

How to use (continued)

■ Peripheral parts of the main unit

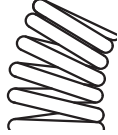
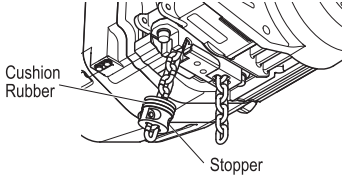
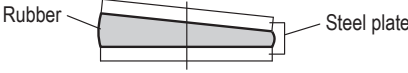
Item	Check method	Criteria	When failed
Chain Spring	<ul style="list-style-type: none"> Check visually 	<ul style="list-style-type: none"> No apparent shrinkage or compression 	Carry out the inspection item of Chain Spring (P73) of Periodic inspection.
Cushion Rubber	<ul style="list-style-type: none"> Check visually  	<ul style="list-style-type: none"> No apparent shrinkage or compression No peel off, crack or deformation of rubber 	Replace the Cushion Rubber.

■ Push Button Switch

Item	Check method	Criteria	When failed
Switch set	<ul style="list-style-type: none"> Check visually 	<ul style="list-style-type: none"> No deformation, damage and no loosened screw Label indication of the push button switch can be seen clearly. 	Clean and repair the label or replace with a new label. Affix the label securely.

■ Function and Performance

- Check the following item with no load.

Item	Check method	Criteria	When failed
Operational Check	<ul style="list-style-type: none"> • Press the push button and check each operation. 	<ul style="list-style-type: none"> • The Load Chain can be wound smoothly. • The Electric chain hoist moves in the same direction as that of the push button operation. • When the operation is stopped, the motor stops immediately. • When the Emergency Stop Button is pressed, all hoist motions stop. • When operating other push button while the Emergency Stop Button is pressed, the hoist does not start operation. • When canceling the Emergency Stop Button, the hoist operates normally. 	Refer to Chapter 3 "Guidance on Troubleshooting" (P92 to 93).
Brake	<ul style="list-style-type: none"> • Press the push button and check the operation of the Brake. 	<ul style="list-style-type: none"> • When stopping the operation, the Brake is applied immediately and the Bottom Hook shall stop immediately. (Guideline: The travel of the Load Chain is within 2 to 3 links.) 	Carry out the inspection in accordance with the items in Chapter 2 "Periodic inspection" Electromagnetic Brake (P75).
Limit Switch	<ul style="list-style-type: none"> • Press the push button and check the operation of the Limit Switch. 	<ul style="list-style-type: none"> • When the hoist is operated to the upper or lower limit, the motor automatically stops. 	Replace the Limit Switch. Disassemble the actuator of the Limit Switch to clean.
Check for no Abnormal Sound	<ul style="list-style-type: none"> • Press the push button and check the operation. <div style="border: 1px solid black; padding: 5px; margin-top: 10px;"> <p style="text-align: center;">NOTE</p> <p>Sound is also an important check point. Always be careful for the noise of the electric chain hoist.</p> </div>	<ul style="list-style-type: none"> • No abnormal sounds and vibrations 	Replace the abnormal part. Apply oil on the Load Chain.
		<ul style="list-style-type: none"> • No popping sound from the Load Chain. 	Check the Load Chain. (Refer to P20.)

How to use (continued)

■ Daily Inspection of Motorized Trolley (EQM)

■ Appearance

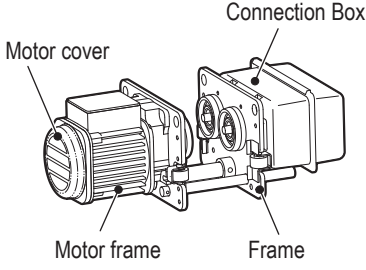
Item	Check method	Criteria	When failed
Indication of Nameplates and Labels	<ul style="list-style-type: none"> Check visually 	<ul style="list-style-type: none"> No peel off. Indication can be seen clearly. 	Clean and repair the label or replace with a new label.
Deformation and damage of each part	<ul style="list-style-type: none"> Check visually 	<ul style="list-style-type: none"> No apparent deformation, damage and corrosion 	Replace the deformed or damaged part.
Loosened or fallen off bolts, nuts and split pins	<ul style="list-style-type: none"> Check visually or using tools. 	<ul style="list-style-type: none"> Bolts, nuts and split pins are fastened securely. <div style="border: 1px solid black; padding: 5px; margin-top: 10px;"> <p style="text-align: center;">⚠ DANGER</p> <p>!</p> <p>Even a drop off of a split pin may cause of drop of the main unit. Be sure to check it.</p> <p>Mandatory</p> <p>Drop off of split pin may result in death or serious injury.</p> </div>	Fasten bolts, nuts and split pins securely.

■ Function and Performance

- Check the following item with no load.

Item	Check method	Criteria	When failed
Operational Check	<ul style="list-style-type: none"> Press the push button to check the operation. 	<ul style="list-style-type: none"> To travel smoothly. No meandering and vibration. The electric chain hoist moves in the same direction as that of the push button operation. When the operation is stopped, the motor stops immediately. When the Emergency Stop Button is pressed, all hoist motions stop. When operating other push button while the Emergency Stop Button is pressed, the hoist does not start operation. When canceling the Emergency Stop Button, the hoist operates normally. 	Refer to Chapter 3 "Guidance on Troubleshooting" (P92 to 93).
Brake	<ul style="list-style-type: none"> Press the push button to check the operation of the Brake. 	<ul style="list-style-type: none"> When the operation is stopped, the Brake is applied and the motor stops immediately. 	Contact KITO.

■ Daily Inspection of Manual Trolley (EQSP)

■ Appearance

Item	Check method	Criteria	When failed
Indication of Nameplates and Labels	<ul style="list-style-type: none"> Check visually 	<ul style="list-style-type: none"> No peel off. Indication can be seen clearly. 	Clean and repair the label or replace with a new label.
Deformation and damage of each part	<ul style="list-style-type: none"> Check visually 	<ul style="list-style-type: none"> No apparent deformation and corrosion No apparent deformation on the Frame 	Replace the deformed or damaged part.
Loosened or fallen off bolts, nuts and split pins	<ul style="list-style-type: none"> Check visually or using tools. 	<ul style="list-style-type: none"> Bolts, nuts and split pins are fastened securely. <div style="border: 1px solid black; padding: 5px; margin-top: 10px;"> <p style="text-align: center;">⚠ DANGER</p> <div style="display: flex; align-items: center;">  <p> <ul style="list-style-type: none"> Even a drop off of a split pin may cause of drop of the main unit. Be sure to check it. </p> </div> <p style="font-size: small;">Drop off of split pin may result in death or serious injury.</p> </div>	Fasten bolts, nuts and split pins securely.

■ Function and Performance

- Check the following item with no load.

Item	Check method	Criteria	When failed
Operational Check	<ul style="list-style-type: none"> Check the traveling motion of the electric chain hoist by moving it manually. 	<ul style="list-style-type: none"> To travel smoothly. No meandering and vibration. 	Carry out Chapter 2 "Periodic inspection".

How to Operate the Push Button Switches

CAUTION



Prohibited

- Do not hang the Push Button Switch Cord on other object, or pull the cord strongly.
- Do not use the Push Button Switch if its button does not operate smoothly.
- Do not bundle or tie the cord for the adjustment of its length.

Failure to comply with this instruction causes bodily injury or loss of property.



Mandatory

- When taking hand off the Push Button Switch after operation, do not throw it. Be careful not to hit other worker with the Push Button Switch.
- When starting operation of the hoist after stopping the hoist by pushing the Emergency Stop Button, be sure to confirm there are no hazards around the workplace before releasing the lock of the Emergency Stop Button and starting operation.

Failure to comply with this instruction causes bodily injury or loss of property.

NOTE

If the Electric chain hoist is tripped due to overheat of the VFD, the VFD cannot be reset soon after the trip. Reset the VFD after a while.

Decompression protection circuit operates when the power is shut down due to power outage, etc.

In this case, Electric Chain Hoist does not operate even when the Push Button Switch is pressed after the power supply is recovered.

To release the halt condition, press the emergency button and reset it.

3-Push Button Switch Set

3-Push Button Switch Set is equipped with a lock type emergency stop button (VFD reset button) and lift/lower push buttons. Two-step push button switch is mounted as Lift/lower push button switches in accordance with the specification of dual speed VFD specification. Refer to the operation method of the corresponding specification.

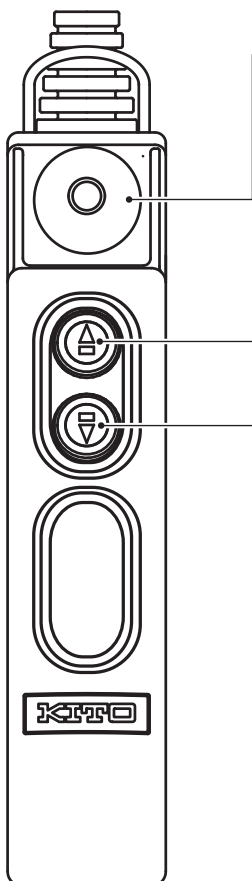

Emergency Stop Button (VFD Reset Button)

- 1) Press the Emergency Stop Button deeply when carrying out an emergency stop or VFD reset.
 - The button is locked at the pressed end.
 - 2) Pull or turn the Emergency Stop Button clockwise to cancel the lock.
 - Press-locked button returns to the original position.
- * Do not pull or turn the Emergency Stop Button hard or excessively.
 * When the electric chain hoist is not used, press the Emergency Stop Button deeply to the end.

Operation Button

Lift/Lower Button

- | | |
|--|--|
| | <ol style="list-style-type: none"> 1) Press button to lift the load. 2) When lifting the load at high speed, press the button further to the end. <ul style="list-style-type: none"> • The electric chain hoist stops when the button is released. |
| | <ol style="list-style-type: none"> 1) Press button to lower the load. 2) When lowering the load at high speed, press the button further to the end. <ul style="list-style-type: none"> • The electric chain hoist stops when the button is released. |

■ 5-Push Button Switch Set

5-Push Button Switch Set is equipped with a lock type emergency stop button (VFD reset button) and lift/lower push buttons. Two-step push button switch is mounted as Lift/lower push button switches in accordance with the specification of dual speed VFD specification. Refer to the operation method of the corresponding specification. Moving direction of the trolley is expressed as East/West for traveling motion in the operational instruction of the Push Button Switch Set.

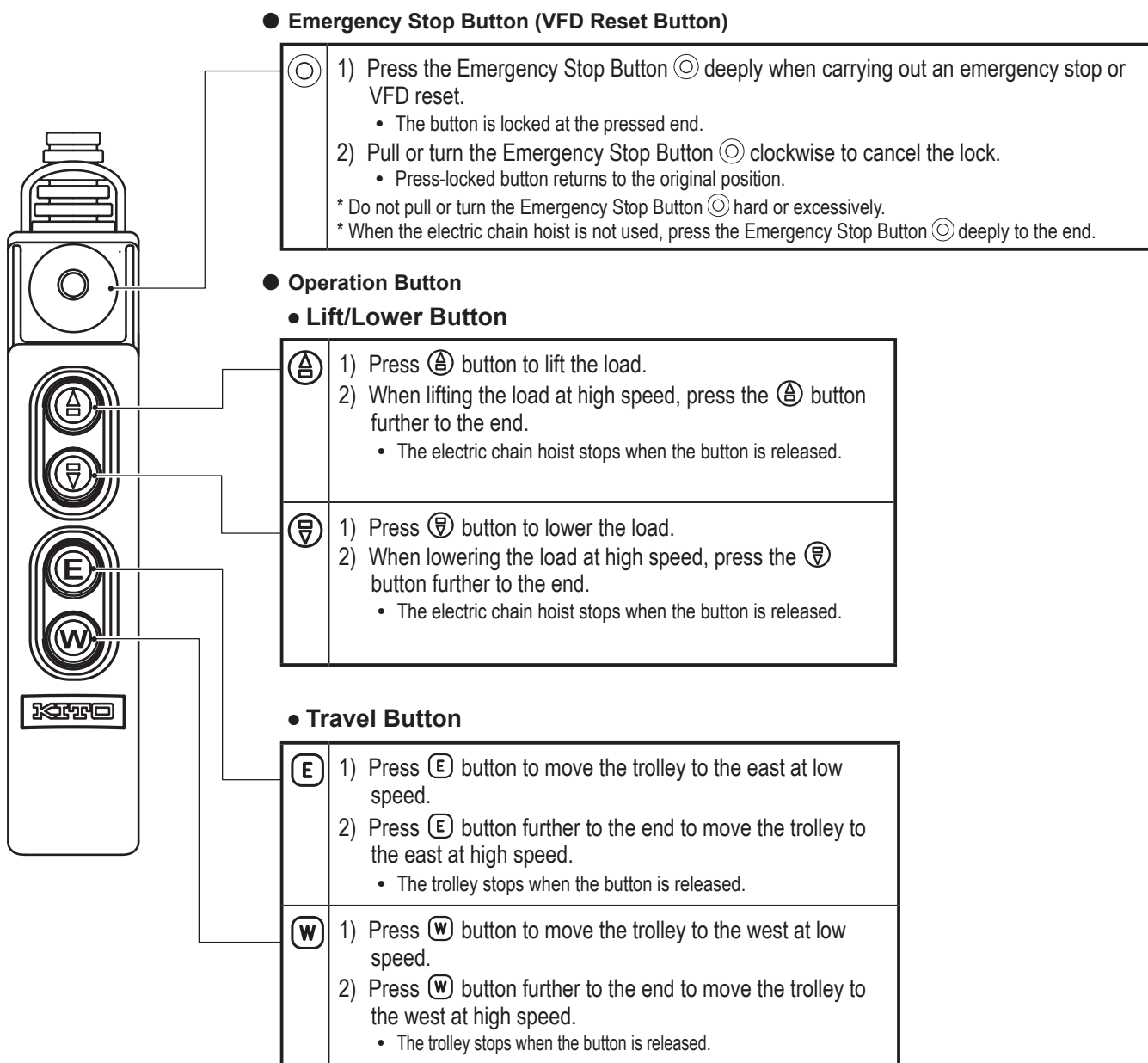

How to use (continued)

How to Use

1

How to Operate the Push Button Switches

■ Operation

■ General

⚠ DANGER



Prohibited

- Do not operate the electric chain hoist in an environment with flammable or explosive gas. The electric chain hoist is not designed as explosion proof specification.
- Do not use the electric chain hoist exceeding the ratings (intermittent rating) of the lifting motor and the maximum start-up frequency.
- Do not use the electric chain hoist by the voltage other than the rated voltage.
- Do not use the Emergency Stop Button for ordinary stop operation.
- Do not expose the Load Chain to sparks from welding.
- Do not contact welding rods or electrodes with the Load Chain.
- Do not use the Load Chain as the earth for welding work. (Fig. A)

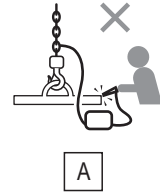

Failure to comply with these instructions may result in death or serious injury.



Mandatory

- Follow the operating environment and conditions for the electric chain hoist.

Failure to comply with this instruction may result in death or serious injury.

■ Slinging

⚠ DANGER



Prohibited

- Do not apply a load to the tip of the Bottom Hook or the Hook Latch. (Fig. B)
- Do not bind a load with the Load Chain directly. (Fig. C)
- Do not operate the Load Chain while it is in contact with any sharp edges. (Fig. D)

Failure to comply with these instructions may result in death or serious injury.

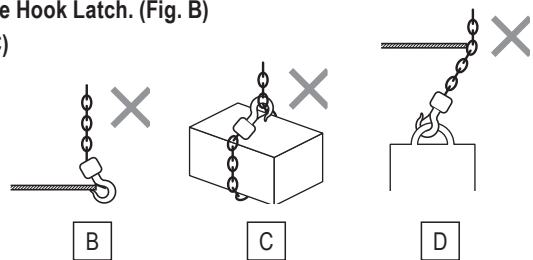

Mandatory

- Use the sling appropriate for the weight and shape of a load. Inappropriate slinging may result in danger such as drop of a lifted load.
- Carry out the slinging with equal load on slinging devices for stable lifting of a load.
- Attach the slinging devices securely to a load.
- Attach the slinging devices to the Bottom Hook correctly.

Failure to comply with these instructions may result in death or serious injury.

How to use (continued)

■ Lifting/Lowering

⚠ DANGER



Prohibited

- **Do not lift more than the capacity. (Fig. E)**
The capacity is indicated in the nameplate.
- **Do not operate the electric chain hoist exceeding the lifting height.**
- **Do not dare to lift the structure or any other object supposed to be difficult to lift.**
- **Do not lift a load at no-load side of the Load Chain.**
- **Do not stop the electric chain hoist with the limit switch (over winding prevention device).**
- **Do not use the electric chain hoist when the Friction Clutch (overload prevention device) is operated to stop winding.**
- **Do not lift or lower excessively.**
 - Do not remove the Chain Spring to operate the limit switch by hitting the body size with the Bottom Hook. If such stop operation is repeated, it may result in breaking of the Load Chain.
 - Do not hit the body size with the End Stopper of the Load Chain to cause the operation of the Friction Clutch. If such operation is repeated, it may result in breaking of the Load Chain.
- **Do not use the main unit as a fulcrum. (Fig. F)**
- **Do not swing the lifted load.**
- **Do not wind the slack Load Chain with a load in one action to avoid exposing the Load Chain to shock.**
Stop lifting when the Load Chain is stretched tight. Then lift slowly.
- **Do not carry out reverse operation while lifting/lowering a load.**
When reversing the motion, stop the electric chain hoist and then reverse the motion.
- **Do not carry out excessively frequent inching.**
- **Do not carry out plugging.**
When reversing the motion, stop the electric chain hoist and then reverse the motion.
- **When lifting off a load from a pallet, lift the load to avoid exposing to shock, such as the load falling. (Fig. G)**
- **Do not cause the load to come into contact with the Load Chain.**
- **Do not rotate a lifted load. Use the device for rotation.**
- **Do not carry out the welding or cutting work on a lifted load.**
- **Do not repair or disassemble a lifted load.**
When repairing or disassembling an electric chain hoist, ensure that the product is placed down on the floor and that only maintenance engineers maintain the electric chain hoist.
- **Do not enter beneath a lifted load.**
- **Do not hit the Chain Container with a load or slinging devices.**
Otherwise the Load Chain in the Chain Container falls out of the bucket to cause injury.
- **Do not leave from the operating position while a load is lifted. Watch the lifted load.**

Failure to comply with these instructions may result in death or serious injury.

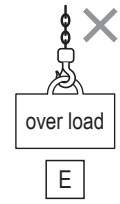

E

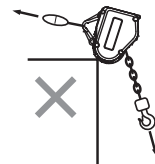

F

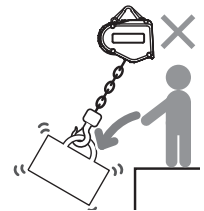

G



Mandatory

- **When the limit switch (over winding prevention device) is operated, stop the lifting work immediately and lower the load.**
- **Move the electric chain hoist right above the load and then lift the load. (Do not lift the load in an inclined direction.) (Fig. H)**

Failure to comply with these instructions may result in death or serious injury.



H

CAUTION

Prohibited

- Do not use the Friction Clutch to measure the weight of a load.

The use of the Friction Clutch other than intended purpose may result in injury or property damage.



Mandatory

- When carrying a lifted load using a lifting magnet or a vacuum chuck, lower the height of the lifted load as low as possible.
- When lifting a load with two electric chain hoists, use the electric chain hoist with the rated lifting capacity of a single hoist exceeding the load.
- When lifting a load with two electric chain hoists, use the electric chain hoists of the same model and capacity and operate the respective electric chain hoist to keep the load lifted or lowered horizontal.

Failure to comply with this instruction causes bodily injury or loss of property.

■ Traverse / Travel**DANGER**

Prohibited

- Do not operate the electric chain hoist underneath the load or transport a load over people. (Fig. I)
- Do not operate the electric chain hoist when any person is in the area where the lifted load moves.
- Do not allow people to enter into the area where a lifted load moves.
- Do not ride on a lifted load and do not use the electric chain hoist to support, lift, or transport people. (Fig. J)
- Do not strike the stopper or the structure by the main unit or the trolley.
- Do not operate or move the electric chain hoist while going backward with a load kept lifted.
Operate the electric chain hoist while looking forward from the back of a load and going ahead.

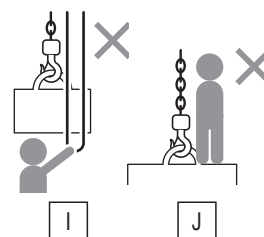

Failure to comply with these instructions may result in death or serious injury.

CAUTION

Prohibited

- Do not impede the lifted load with other structure or wiring.

Failure to comply with this instruction causes bodily injury or loss of property.

■ In Abnormality or Failure**DANGER**

Mandatory

- If the electric chain hoist is damaged or abnormal noise or vibration occurs, stop the operation immediately.
- If the electric chain hoist moves in the direction opposite to the indication on the Push Button Switch, stop the operation immediately.
- When the twist, entanglement, crack, deformation, attachment of foreign matters or abnormal engagement of the Load Chain and the Gear is observed, stop the operation immediately.
- When any abnormality is observed during the operation, indicate "FAILURE" and contact with the maintenance engineers.
- When the power is interrupted, secure safety and contact with the maintenance engineers.

Failure to comply with these instructions may result in death or serious injury.

How to use (continued)

Speed Change of Dual Speed for EQ Model

You can change the high/low speed of the dual speed for EQ model by changing the VFD parameter.

⚠ DANGER



Prohibited

- Do not disassemble the Model EQ Electric Chain Hoist in the same way as the contactor system.
- Only maintenance engineers or the personnel with expertise are allow to set or change the parameters. Wrong parameter settings may result in danger such as defective operation and drop of lifted load. Please contact your nearest service shop or KITO for consultation.

Failure to comply with these instructions may result in death or serious injury.



Mandatory

- When changing the parameter, set it correctly referring to the VFD Manual.
- Parameter change requires energizing. Do not touch the energized part.

Failure to comply with these instructions may result in death or serious injury.

How to Sling the Load Properly

Do not carry out dangerous hooking as shown below.

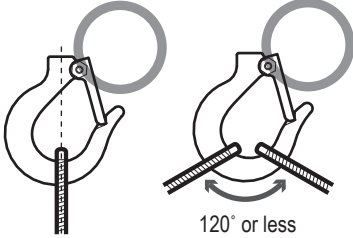

120° or less

Sling the load at the extended line of the hook shaft.



Improper hooking position of the lifted load or the sling



Angle exceeding 120°
Angle too wide



Unable closing of the Hook Latch

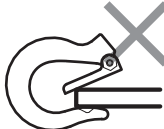

Hooking of the load at the tip of the Hook

How to Suppress the Swinging of a Load

⚠ DANGER



Prohibited

- Do not move the electric chain hoist with a load hung at one side of the Crane Saddle.

Otherwise the load swings and hits a person or object or drops to result in death or serious injury.

Swinging of a load makes it difficult and dangerous to move the trolley. The basics of operation are not to make a load swing. To do that keep the following instructions.

- Do not lift a load in an inclined direction.
- Start slowly when traveling the load.
- Do not lift suddenly.

Even if you keep the above instructions, the lifted load may swing at the start and the stop of the electric chain hoist. Following operation can reduce the swing of the lifted load.

Operation

- Press the Travel Button. (Fig. a)
- When the trolley starts to move, the lifted load delays a bit. (Fig. b)
- Release the button a bit before the time when the lifted load swings to the center position.
- When the lifted load comes to the position just beneath the electric chain hoist, press the button again and continue to travel the load. (Fig. c)

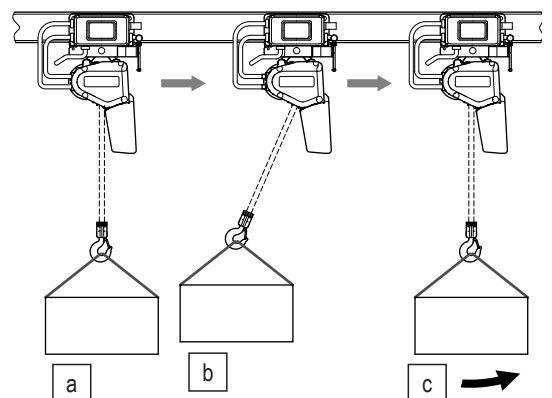

■ Precautions After Work

⚠ CAUTION



Prohibited

- Do not store the electric chain hoist at a state of over lifting or over lowering.

Failure to comply with these instructions causes bodily injury or loss of property.



Mandatory

- Store the electric chain hoist with power off.
- Indicate "FAILURE" on the electric chain hoist that needs repair not to be used.
- Wipe off dust and waterdrop, apply oil at the neck of the Hook and the Load Chain and store the hoist.
- Remove the stain, attached foreign matter and waterdrop from the parts such as the Limit Switch and the Chain Container that is scratched by the Load Chain and stored it.
- When the electric chain hoist is installed outdoor, cover it with rain cover or roof after application of rust proof process.

Failure to comply with these instructions causes bodily injury or loss of property.

NOTE

- Clean the push button switches always not to allow the dust, sands and oil attach.
- When storing the electric chain hoist for a long period, it is effective to prevent rusting to operate it at a certain period without load.
- When putting the electric chain hoist on a floor, remove the Chain Container. Otherwise the Chain Container may deform or be damaged.
- When not using the electric chain hoist, wind up the Bottom Hook to the height not to hinder persons passing by or other work.
- Decide the place to store the electric chain hoist in advance. It is recommended to hang the push button cable on the pillar.

■ Setting Up the No-Load High-Speed Function

The EQ Series Electric Chain Hoist provides the no-load high-speed function. When you enable this function, operation is automatically switched to 1.3 times faster than high-speed during high-speed operation if a load is between no-load and 30% of rated load.

This function is set to enable in the factory-preset mode.

■ Enabling/Disabling the No-Load High-Speed Function

To enable or disable the no-load high-speed function setting, use push button switches.

- | | |
|---|--|
| <ul style="list-style-type: none"> ● To enable the no-load high-speed function <ol style="list-style-type: none"> 1. Perform lowering operation to activate the lower limit switch. 2. Press the emergency stop button. 3. Press and hold the first row of the lowering button (low-speed) for 5 seconds or more. 4. Release the emergency stop button. | <ul style="list-style-type: none"> ● To disable the no-load high-speed function <ol style="list-style-type: none"> 1. Perform lowering operation to activate the lower limit switch. 2. Press the emergency stop button. 3. Press and hold the second row of the lowering button (high-speed) for 5 seconds or more. 4. Release the emergency stop button. |
|---|--|

⚠ DANGER



Prohibited

Do not wind the slack Load Chain with a load in one action to avoid exposing the Load Chain to shock.

Stop lifting when the Load Chain is stretched tight. Then lift slowly.

⚠ CAUTION



Mandatory

When you use the no-load high-speed function for the first time and when you set it to enabled, confirm that operation is automatically switched to 1.3 times speed during high-speed operation.

Failure to comply with these instructions may result in bodily injury or property damage.

(to be continued)

Work Flow of Assembling and Installation

The contents of the work to assemble and install the product by the maintenance engineers and installer are described from this page and after. To eliminate the redo work and for effective assembling and installation, please check the following work flow first and then start assembling and installation work.

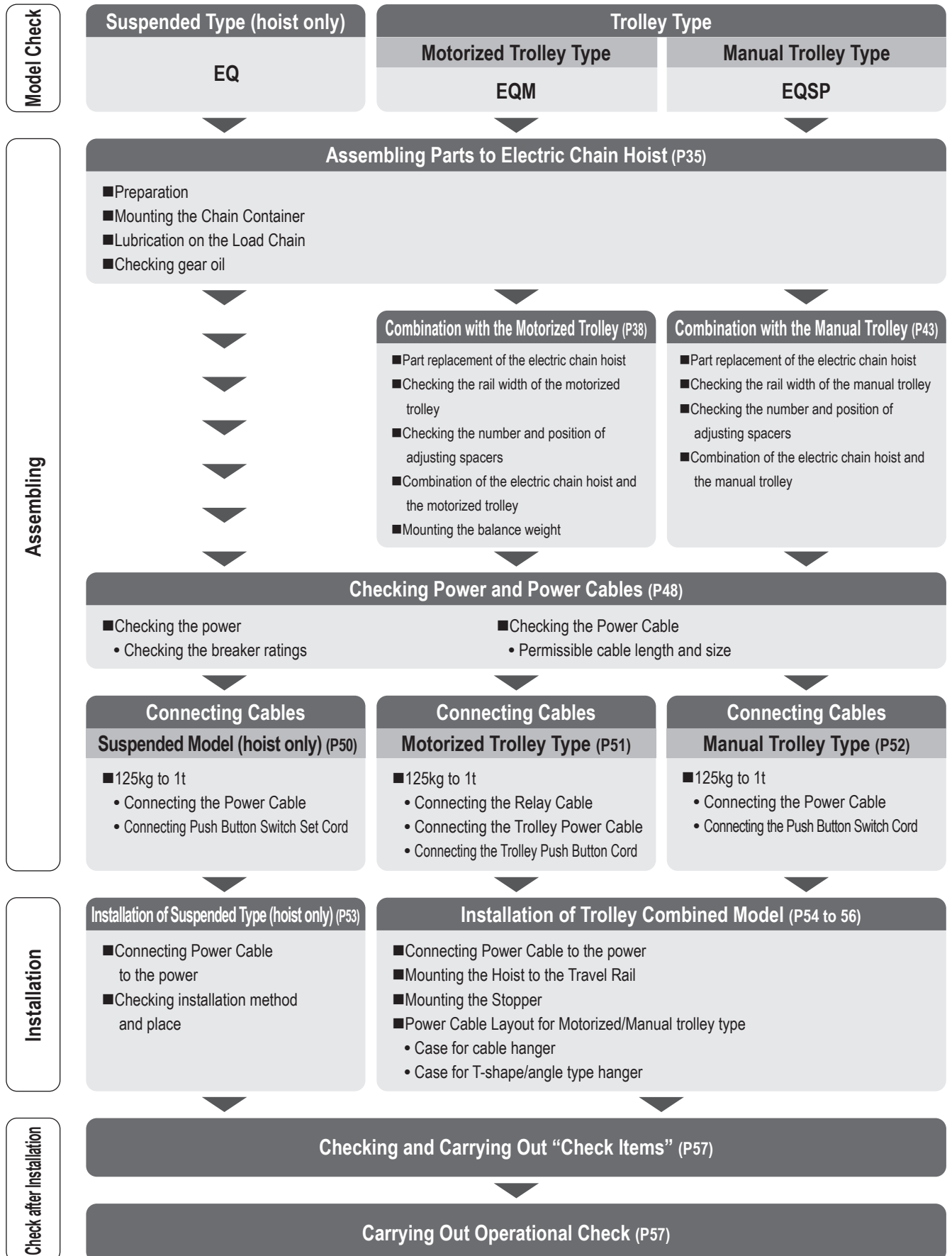

Assembling

DANGER



Prohibited

- Only maintenance engineers or the personnel with expertise are allowed to assemble and disassemble the electric chain hoist.

Assembling or disassembling of the electric chain hoist may result in death or serious injury.

■ Assembling Parts to Electric Chain Hoist

■ Preparation for Assembling

- Hang the electric chain hoist body size to facilitate the mounting of the Chain Container.
- Check that the stopper and the cushion rubber are mounted at the link third from the no load side of the Load Chain (the end without the Bottom Hook).

■ Mounting the Chain Container

The Chain Container is made of plastic. (Canvas container is available as an option.)

DANGER



Mandatory

- The each type of Chain Container has the capacity to store the specific amount of the Load Chain. Use correct capacity of the Chain Container.

When storing the Load Chain of which amount exceeds the capacity of the Chain Container, it may result in death or serious injury due to the flow over of the Load Chain from the Chain Container or defective operation of the electric chain hoist.

Improper combination of the Chain Container and the electric chain hoist is very dangerous because of the possibility of drop of the Chain Container.

The seal to indicate the capacity and lifting height is attached on the Chain Container. Check it before use.

- If the Chain Container is not assembled correctly, it may result in death or serious injury due to a drop of the Chain Container or Load Chain, and malfunction of the Electric Chain Hoist.

Refer to the assembling instruction on the page 38 and assemble the Chain Container correctly.

Failure to comply with these instructions causes bodily injury or loss of property.

CAUTION



Mandatory

- When storing the Load Chain into the Chain Container, put the chain end with no-load side first and then store the rest of the Load Chain.

Failure to comply with these instructions causes bodily injury or loss of property.

Assembling (continued)

● Assembling the Chain Container

- 1) Pass a Socket Bolt through all holes of the Chain Container, the Body and the Chain Container, in this order to mount the Chain Container.

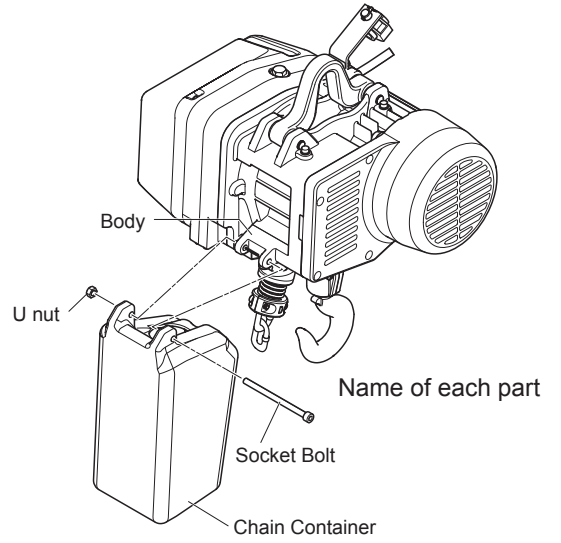
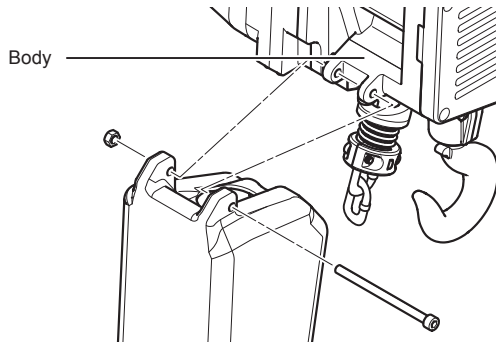

- 2) Screw the U nut into the Socket bolt and tighten it securely.

- The Socket Bolt must protrude from the end face of the nut by three threads or more.

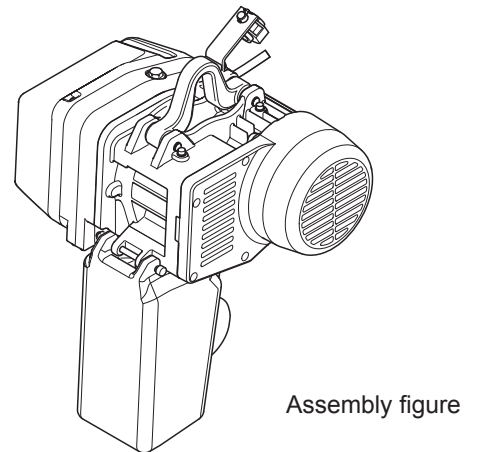
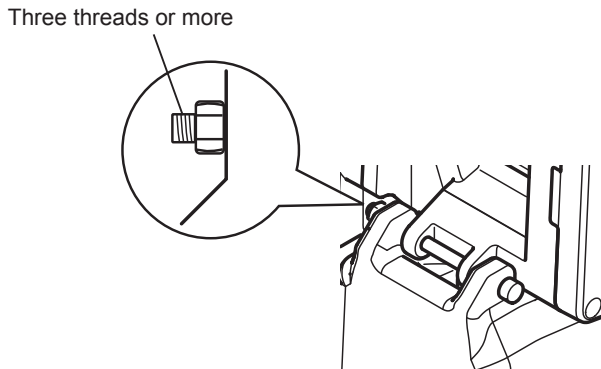

■ Oiling the Load Chain

⚠ DANGER



Mandatory

- Be sure to apply lubricant on the Load Chain. Do not carry out oiling work in the place near the fire or arc. Otherwise it will result in fire.

- Remove dust and waterdrops attached on the Load Chain and then apply lubricant. Application of lubricant influences on the life of the Load Chain considerably. Apply the lubricant sufficiently. Use the following genuine lubricant.
 - Epinoc Grease AP (N)0 (Nippon Oil Corporation)
 - Consistency No.0 (Industrial general lithium grease)

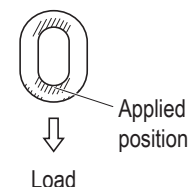
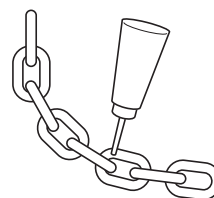

- Release all loads from the Load Chain and apply the lubricant all over the Load Chain. After application of the lubricant lift/lower the electric chain hoist without load to spread the lubricant on the Load Chain.

■ Gear Oil

Inside of the Gear Case is filled with gear oil at the shipping. The level of the oil filled with specified amount comes to the height of the inspection hole. Check the oil level visually.

⚠ DANGER



Mandatory

- Use genuine gear oil. Use of the gear oil other than the genuine oil (including mixed use) will result in death or serious injury due to the drop of the lifted load.

● Cheking the Gear Oil Amount

1) Remove the Oil Plug on the upper Main Body

- 2) Insert the check bar from the Oil check hole to check the oil level. (The normal distance between the hole and the oil level is between 107 to 111 mm for the body size D, and 101 to 105 mm for the body size C.)

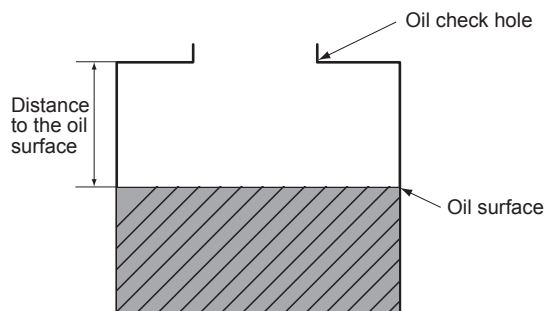
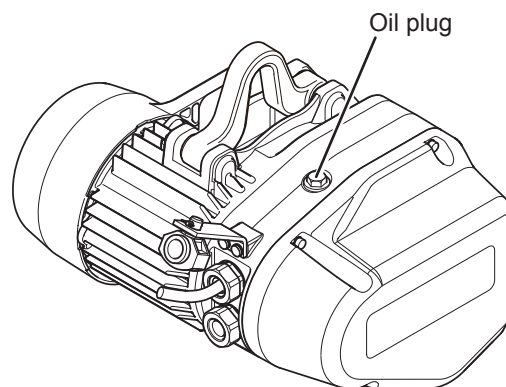

(to be continued)

Assembling (continued)

■ Combination with the Trolley

* You do not have to read the contents below if you use the hoist as Hook Suspension Model. Go to "Checking Power and Power Cable" (P48).

⚠ DANGER

Mandatory

- Adjust the rail width during assembling and install.
- Be careful for the Power Cable and Push Button Switch Set Cord are not pulled off or entangled within the area of traveling area.

Failure to comply with these instructions may result in death or serious injury.

Hoist itself, or combination with KITO EQ trolley or a trolley for some light cranes.

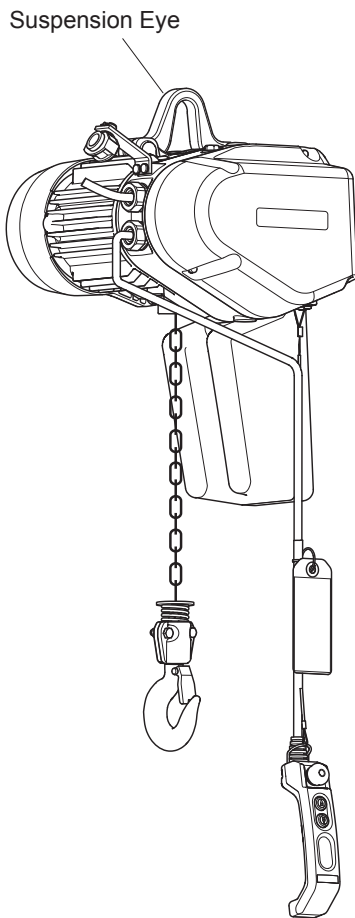

Part name	Usage	Part code 125kg to 500kg	Part code 1t
Suspension Eye	Hoist itself, or combination with KITO EQ trolley or a trolley for some light cranes.	EQ1C19001	EQ1D19001

■ Dimensions of Suspension Eye

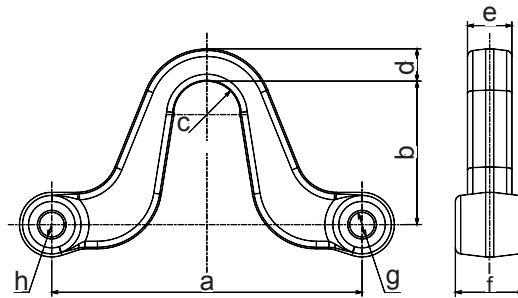

Code	Part code	a	b	c	d	e	f	g	h
001IS, 003IS, 004IS, 005IS	EQ1C19001	139.6	67.5	16.5	8	16	33	Ø12.2	16
010IS	EQ1D19001	153.6	71	16.5	12.3	22	34		

■ Combining with the Motorized Trolley

⚠ CAUTION

Prohibited

- You cannot combine other KITO product (old model) with the Model EQ Electric Chain Hoist.

■ Checking the Number of the Assembled Adjusting Spacers and Their Positions (for Motorized Trolley)

When installing a trolley to the beam, the length of the Suspension Shaft (width between frames) must be adjusted in accordance with the rail width.

Wrong number of wrong position of Spacers may result in the drop of the electric chain hoist.

Insert the correct number of Spacers with correct ratings and for rail width at the correct position, referring to the following table.

(Unit: piece)

Capacity	Parts name	Rail width (in)	25/16	21/2 25/8	27/8 215/16	3	31/4	39/16	37/8	315/16	4	43/16	45/16	47/16	411/16 43/4	415/16	5	
		Rail width (mm)	58	64 66	73 74	75 76	82	90 91	98	100	102	106	110	113	119 120	125	127	
125kg 250kg 490kg 500kg	Thin spacer	Inner	1+2	2+3	4+4	1+0	1+2	2+3	0+0	1+0	1+0	1+2	2+2	2+3	3+4	4+4	1+0	
		Outer	5	3	0	7	5	3	8	7	7	5	4	3	1	0	3	
	Thick spacer	Inner	0+0	0+0	0+0	0+0	0+0	0+0	0+0	1+1	1+1	1+1	1+1	1+1	1+1	1+1	1+1	1+1
		Outer	5	5	5	5	5	5	3	3	3	3	3	3	3	3	3	2
	Fixing spacer (300)	Inner	-	-	-	-	-	-	-	-	-	-	-	-	-	-	-	-
		Outer	-	-	-	-	-	-	-	-	-	-	-	-	-	-	-	-
	Thick spacer L	Inner	0	0	0	1+1	1+1	1+1	1+1	1+1	1+1	1+1	1+1	1+1	1+1	1+1	1+1	1+1
		Outer	2	2	2	0	0	0	0	0	0	0	0	0	0	0	0	0
	Thin spacer L	Inner	1+1	1+1	1+1	1+1	1+1	1+1	1+1	1+1	1+1	1+1	1+1	1+1	1+1	1+1	1+1	1+1
		Outer	1+1	1+1	1+1	1+1	1+1	1+1	1+1	1+1	1+1	1+1	1+1	1+1	1+1	1+1	1+1	1+1
	1t	Thin spacer	Inner	0+1	1+2	3+3	4+3	5+4	6+5	3+3	4+3	4+3	5+4	5+5	6+5	7+6	7+7	7+4
			Outer	13	11	8	7	5	3	8	7	7	5	4	3	1	0	3
Thick spacer		Inner	0+0	0+0	0+0	0+0	0+0	0+0	0+0	1+1	1+1	1+1	1+1	1+1	1+1	1+1	1+1	1+2
		Outer	5	5	5	5	5	5	3	3	3	3	3	3	3	3	3	2
Fixing spacer (300)		Inner	-	-	-	-	-	-	-	-	-	-	-	-	-	-	-	-
		Outer	-	-	-	-	-	-	-	-	-	-	-	-	-	-	-	-
Thin spacer L		Inner	1+1	1+1	1+1	1+1	1+1	1+1	1+1	1+1	1+1	1+1	1+1	1+1	1+1	1+1	1+1	1+1
		Outer	1+1	1+1	1+1	1+1	1+1	1+1	1+1	1+1	1+1	1+1	1+1	1+1	1+1	1+1	1+1	1+1

(Unit: piece)

Capacity	Parts name	Rail width (in)	53/16	55/16	53/8	55/8	57/8 515/16	6	61/8	65/16	67/16	611/16	67/8	7	71/16 71/8	71/4 75/16	77/8	
		Rail width (mm)	131	135	137	143	149 150	153	155	160	163	170	175	178	180 181	184 185	200	
125kg 250kg 490kg 500kg	Thin spacer	Inner	5+1	2+2	2+2	3+3	4+4	4+1	1+1	2+2	2+3	3+0	4+4	4+1	1+1	1+2	4+4	
		Outer	2	4	4	2	0	3	6	4	3	5	0	3	6	5	0	
	Thick spacer	Inner	1+2	2+2	2+2	2+2	2+2	2+3	3+3	3+3	3+3	3+4	3+3	3+4	0+0	0+0	0+0	
		Outer	2	1	1	1	1	0	3	3	3	2	3	2	9	9	9	
	Fixing spacer (300)	Inner	-	-	-	-	-	-	0+0	0+0	0+0	0+0	0+0	0+0	1+1	1+1	1+1	
		Outer	-	-	-	-	-	-	2	2	2	2	2	2	0	0	0	
	Thick spacer L	Inner	1+1	1+1	1+1	1+1	1+1	1+1	1+1	1+1	1+1	1+1	1+1	1+1	1+1	1+1	1+1	
		Outer	0	0	0	0	0	0	0	0	0	0	0	0	0	0	0	
	Thin spacer L	Inner	1+1	1+1	1+1	1+1	1+1	1+1	1+1	1+1	1+1	1+1	1+1	1+1	1+1	1+1	1+1	
		Outer	1+1	1+1	1+1	1+1	1+1	1+1	1+1	1+1	1+1	1+1	1+1	1+1	1+1	1+1	1+1	
	1t	Thin spacer	Inner	8+4	5+5	5+5	6+6	7+7	7+4	4+4	5+5	6+5	6+3	7+7	7+4	4+4	5+4	7+7
			Outer	2	4	4	2	0	3	6	4	3	5	0	3	6	5	0
Thick spacer		Inner	1+2	2+2	2+2	2+2	2+2	2+3	3+3	3+3	3+3	3+4	3+3	3+4	0+0	0+0	0+0	
		Outer	2	1	1	1	1	0	3	3	3	2	3	2	9	9	9	
Fixing spacer (300)		Inner	-	-	-	-	-	-	0+0	0+0	0+0	0+0	0+0	0+0	1+1	1+1	1+1	
		Outer	-	-	-	-	-	-	2	2	2	2	2	2	0	0	0	
Thin spacer L		Inner	1+1	1+1	1+1	1+1	1+1	1+1	1+1	1+1	1+1	1+1	1+1	1+1	1+1	1+1	1+1	
		Outer	1+1	1+1	1+1	1+1	1+1	1+1	1+1	1+1	1+1	1+1	1+1	1+1	1+1	1+1	1+1	

(to be continued)

Assembling (continued)

(Unit: piece)

Capacity	Parts name	Rail width (in)	8	87/16	811/16	9	91/8	97/8	10	101/8	101/4	103/8	101/2	11	111/8	111/4	113/8
		Rail width (mm)	203	215	220	229	232	250	254	257	260	264	267	279	283	286	289
125kg 250kg 490kg 500kg	Thin spacer	Inner	5+0	2+3	3+4	1+1	1+2	4+0	1+1	1+2	2+2	2+3	3+3	1+1	1+2	2+2	2+3
		Outer	3	3	1	6	5	4	6	5	4	3	2	6	5	4	3
	Thick spacer	Inner	0+1	1+1	1+1	2+2	2+2	2+3	3+3	3+3	3+3	3+3	3+3	4+4	4+4	4+4	4+4
		Outer	8	7	7	5	5	4	3	3	3	3	3	1	1	1	1
	Fixing spacer (300)	Inner	1+1	1+1	1+1	1+1	1+1	1+1	1+1	1+1	1+1	1+1	1+1	1+1	1+1	1+1	1+1
		Outer	0	0	0	0	0	0	0	0	0	0	0	0	0	0	0
Thin spacer L	Inner	1+1	1+1	1+1	1+1	1+1	1+1	1+1	1+1	1+1	1+1	1+1	1+1	1+1	1+1	1+1	
	Outer	0	0	0	0	0	0	0	0	0	0	0	0	0	0	0	

(Unit: piece)

Capacity	Parts name	Rail width (in)	115/8	113/4	1113/16	117/8	12
		Rail width (mm)	295	298	300	302	305
125kg 250kg 490kg 500kg	Thin spacer	Inner	3+0	4+0	4+1	4+1	4+2
		Outer	5	4	3	3	2
	Thick spacer	Inner	4+5	4+5	4+5	4+5	4+5
		Outer	0	0	0	0	0
	Fixing spacer (300)	Inner	1+1	1+1	1+1	1+1	1+1
		Outer	0	0	0	0	0
Thin spacer L	Inner	1+1	1+1	1+1	1+1	1+1	
	Outer	0	0	0	0	0	

Rail width of 58 – 153 (mm): Normal suspension shaft;
 Rail width of 155 – 305 (mm): Wide-frange suspension shaft

0+1
 0: the number of spacers on the Frame G side of the shaft
 1: the number of spacers on the Frame S side of the shaft

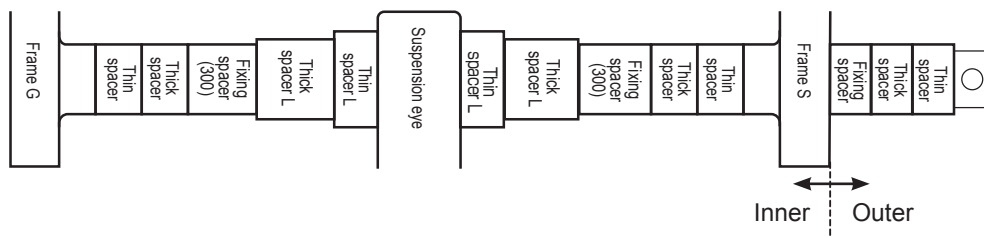

Length of Adjusting Spacer

(Unit: mm)

		125kg, 250kg, 490kg, 500kg, 1t*
Thick spacer	A	12.5
	B	38.4
	C	32
Fixing spacer (300)	A	50
	B	38.4
	C	32
Thick spacer L*	A	12.5
	B	45
	C	32
Thin spacer L	A	5.5
	B	50.8
	C	32.8
Thin spacer	A	3.2
	B	43
	C	32.5
Suspension shaft diameter		31

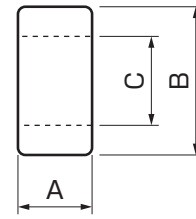

Thick spacer/Fixing spacer (300)/Thick spacer L/Thin spacer L/Thin spacer

* Thick spacer L is not necessary for 1t type. Please remove it if it is in.

Assembling (continued)

■ Combination of the Electric Chain Hoist and the Motorized Trolley

⚠ DANGER



Mandatory

- Use new split pins. After insertion, bend the pin securely at its both ends.
Use of old split pins may result in death or serious injury due to drop.

● 125kg to 1t

1) Fix the Suspension Shaft to the Frame G with a Suspension Shaft Bolt, a slotted nut and a split pin.

- When fixing the Frame S and the Suspension Shaft, use the hole A. If the gap between the rail end and the wall of the housing is scarce to install the electric chain hoist to the travel rail, use the hole B. (Refer to "Mounting the Hoist to the Travel Rail" (P54).)

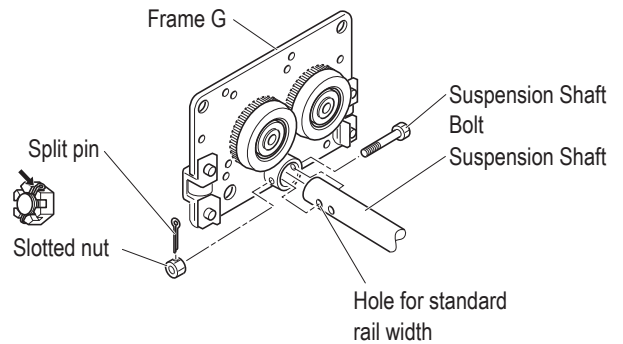

<Suspension Shaft>

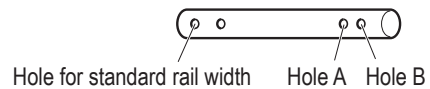

⚠ DANGER



Prohibited

- The hole B on the Suspension Shaft is the hole for mounting work (temporary assembly). Do not use the hole for the adjustment of rail width.

Failure to comply with this instruction may result in death or serious injury.

2) Set the Suspension Shaft with a Thin Spacer, Thick Spacer, Fixing Spacers, Thick Spacer L and a Thin Spacer L.

3) Hook the Suspension eye on the Suspension Shaft.

4) Set the Suspension Shaft with another Thin Spacer, Thick Spacer, Fixing Spacers, Thick Spacer L and Thin Spacer L. Then insert the Suspension Shaft into the Frame S.

- Adjust the Spacers in accordance with the rail width. (Refer to "Checking the Number of the Assembled Adjusting Spacers and Their Positions" (P39, 40) for the number of Spacers.)

5) Set the Suspension Shaft with a Thick Spacer. Insert the Shaft Stopper Pin into the Hole A and fix it with a split pin.

- Insert the Shaft Stopper Pin in the direction that the split pin comes to the left when viewed from the front side of the MR2Q Connection Box.

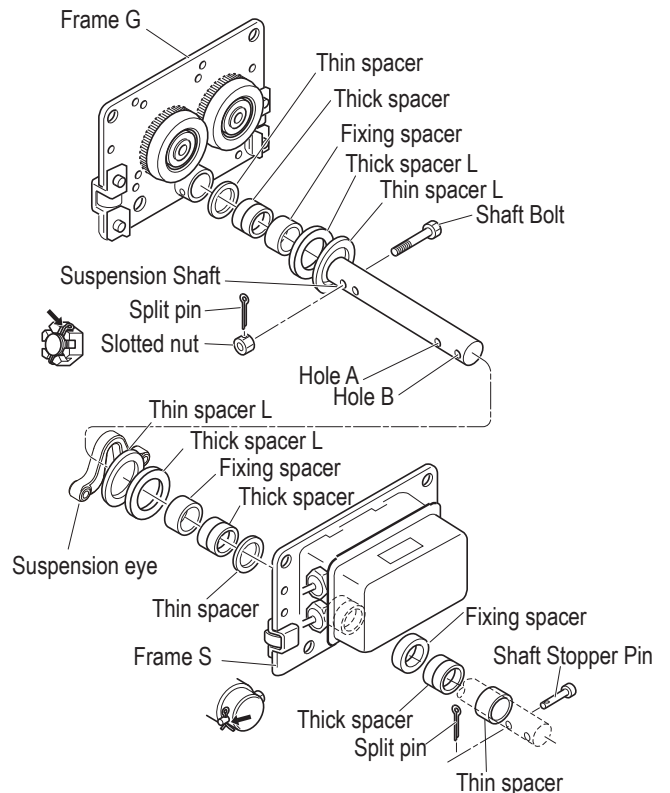

■ Combination with the Manual Trolley

■ Checking the Number of the Assembled Adjusting Spacers and Their Positions (for Manual Trolley)

When installing a trolley to the beam, the length of the Suspension Shaft (width between frames) must be adjusted in accordance with the rail width. Wrong number of wrong position of Spacers may result in the drop of the electric chain hoist. Insert the correct number of Spacers with correct ratings and for rail width at the correct position, referring to the following table.

125kg - 500kg

(Unit: piece)

Capacity (Plain trolley)	Parts name	Rail width (in)	2	25/16	21/2 25/8	27/8 215/16	3	31/4	39/16	37/8	315/16	4	43/16	45/16	47/16	411/16 43/4	415/16	5
		Rail width (mm)	50	58	64 66	73 74	75 76	82	90 91	98	100	102	106	110	113	119 120	125	127
125kg 250kg 490kg 500kg	Thin spacer	Inner	2+3	3+4	0+1	1+2	2+2	3+3	0+1	1+2	2+2	2+3	1+1	1+2	2+2	3+3	0+0	0+1
		Outer	4	2	8	6	5	3	8	6	5	4	7	6	5	3	9	8
	Thick spacer	Inner	0+0	0+0	1+1	1+1	1+1	1+1	2+2	2+2	2+2	2+2	0+0	0+0	0+0	0+0	1+1	1+1
		Outer	4	4	2	2	2	2	0	0	0	0	7	7	7	7	5	5
	Thick spacer L	Inner	1+1	1+1	1+1	1+1	1+1	1+1	1+1	1+1	1+1	1+1	1+1	1+1	1+1	1+1	1+1	1+1
		Outer	0	0	0	0	0	0	0	0	0	0	0	0	0	0	0	0
	Fixing spacer	Inner	-	-	-	-	-	-	-	-	-	-	-	1+1	1+1	1+1	1+1	1+1
			-	-	-	-	-	-	-	-	-	-	-	-	-	-	-	-

1t

(Unit: piece)

Capacity (Plain trolley)	Parts name	Rail width (in)	2	25/16	21/2 25/8	27/8 215/16	3	31/4	39/16	37/8	315/16	4	43/16	45/16	47/16	411/16 43/4	415/16	5
		Rail width (mm)	50	58	64 66	73 74	75 76	82	90 91	98	100	102	106	110	113	119 120	125	127
1t	Thin spacer	Inner	-	3+3	0+0	1+1	1+2	2+3	0+0	1+1	1+2	2+2	2+3	3+3	3+4	0+1	1+2	2+2
		Outer	-	2	8	6	5	3	8	6	5	4	3	2	1	7	5	4
	Thick spacer	Inner	-	0+0	1+1	1+1	1+1	1+1	2+2	2+2	2+2	2+2	2+2	2+2	2+2	3+3	3+3	3+3
		Outer	-	6	4	4	4	4	2	2	2	2	2	2	2	0	0	0
	Thick spacer L	Inner	-	1+1	1+1	1+1	1+1	1+1	1+1	1+1	1+1	1+1	1+1	1+1	1+1	1+1	1+1	1+1
		Outer	-	0	0	0	0	0	0	0	0	0	0	0	0	0	0	0
	Fixing spacer	Inner	-	-	-	-	-	-	-	-	-	-	-	-	-	-	-	-
			-	-	-	-	-	-	-	-	-	-	-	-	-	-	-	-

Assembling (continued)

125kg - 500kg

(Unit: piece)

Capacity (Plain trolley)	Parts name	Rail width (in)	53/16	55/16	53/8	55/8	57/8 515/16	6	61/8	65/16	67/16	611/16	67/8	7	71/16 71/8	71/4 75/16	77/8	8	
		Rail width (mm)	131	135	137	143	149 150	153	155	160	163	170	175	178	180 181	184 185	200	203	
125kg 250kg 490kg 500kg	Thin spacer	Inner	1+1	1+2	2+2	3+3	0+0	0+1	1+1	1+2	2+2	3+3	0+0	0+1	1+1	1+2	4+4	4+5	
		Outer	7	6	5	3	9	8	7	6	5	3	9	8	7	6	1	0	
	Thick spacer	Inner	1+1	1+1	1+1	1+1	2+2	2+2	2+2	2+2	2+2	2+2	3+3	3+3	3+3	3+3	3+3	3+3	3+3
		Outer	5	5	5	5	3	3	3	3	3	3	1	1	1	1	1	1	
	Thick spacer L	Inner	1+1	1+1	1+1	1+1	1+1	1+1	1+1	1+1	1+1	1+1	1+1	1+1	1+1	1+1	1+1	1+1	1+1
		Outer	0	0	0	0	0	0	0	0	0	0	0	0	0	0	0	0	0
	Fixing spacer	Inner	1+1	1+1	1+1	1+1	1+1	1+1	1+1	1+1	1+1	1+1	1+1	1+1	1+1	1+1	1+1	1+1	1+1

1t

(Unit: piece)

Capacity (Plain trolley)	Parts name	Rail width (in)	53/16	55/16	53/8	55/8	57/8 515/16	6	61/8	65/16	67/16	611/16	67/8	7	71/16 71/8	71/4 75/16	77/8	8
		Rail width (mm)	131	135	137	143	149 150	153	155	160	163	170	175	178	180 181	184 185	200	203
1t	Thin spacer	Inner	1+1	1+2	2+2	3+3	0+0	0+1	1+1	1+2	2+2	3+3	0+0	0+1	1+1	1+2	4+4	4+5
		Outer	7	6	5	3	9	8	7	6	5	3	9	8	7	6	1	0
	Thick spacer	Inner	0+0	0+0	0+0	0+0	1+1	1+1	1+1	1+1	1+1	1+1	2+2	2+2	2+2	2+2	2+2	2+2
		Outer	5	5	5	5	3	3	3	3	3	3	1	1	1	1	1	1
	Thick spacer L	Inner	1+1	1+1	1+1	1+1	1+1	1+1	1+1	1+1	1+1	1+1	1+1	1+1	1+1	1+1	1+1	1+1
		Outer	0	0	0	0	0	0	0	0	0	0	0	0	0	0	0	0
	Fixing spacer	Inner	1+1	1+1	1+1	1+1	1+1	1+1	1+1	1+1	1+1	1+1	1+1	1+1	1+1	1+1	1+1	1+1

125kg - 500kg

(Unit: piece)

Capacity (Plain trolley)	Parts name	Rail width (in)	87/16	811/16	9	91/8	97/8	10	101/8	101/4	103/8	101/2	11	111/8	111/4	113/8	115/8	113/4
		Rail width (mm)	215	220	229	232	250	254	257	260	264	267	279	283	286	289	295	298
125kg 250kg 490kg 500kg	Thin spacer	Inner	2+3	3+3	4+5	1+1	0+0	0+1	1+1	1+2	2+2	2+3	4+5	1+1	1+2	2+2	3+3	3+4
		Outer	4	3	0	7	9	8	7	6	5	4	0	7	6	5	3	2
	Thick spacer	Inner	0+0	0+0	0+0	1+1	2+2	2+2	2+2	2+2	2+2	2+2	2+2	3+3	3+3	3+3	3+3	3+3
		Outer	7	7	7	5	3	3	3	3	3	3	3	1	1	1	1	1
	Thick spacer L	Inner	1+1	1+1	1+1	1+1	1+1	1+1	1+1	1+1	1+1	1+1	1+1	1+1	1+1	1+1	1+1	1+1
		Outer	0	0	0	0	0	0	0	0	0	0	0	0	0	0	0	0
	Fixing spacer	Inner	1+1	1+1	1+1	1+1	1+1	1+1	1+1	1+1	1+1	1+1	1+1	1+1	1+1	1+1	1+1	1+1

1t

(Unit: piece)

Capacity (Plain trolley)	Parts name	Rail width (in)	87/16	811/16	9	91/8	97/8	10	101/8	101/4	103/8	101/2	11	111/8	111/4	113/8	115/8	113/4
		Rail width (mm)	215	220	229	232	250	254	257	260	264	267	279	283	286	289	295	298
1t	Thin spacer	Inner	2+3	3+3	4+5	1+1	0+0	0+1	1+1	1+2	2+2	2+3	4+5	1+1	1+2	2+2	3+3	3+4
		Outer	4	3	0	7	9	8	7	6	5	4	0	7	6	5	3	2
	Thick spacer	Inner	0+0	0+0	0+0	1+1	2+2	2+2	2+2	2+2	2+2	2+2	2+2	3+3	3+3	3+3	3+3	3+3
		Outer	7	7	7	5	3	3	3	3	3	3	3	1	1	1	1	1
	Thick spacer L	Inner	1+1	1+1	1+1	1+1	1+1	1+1	1+1	1+1	1+1	1+1	1+1	1+1	1+1	1+1	1+1	1+1
		Outer	0	0	0	0	0	0	0	0	0	0	0	0	0	0	0	0
	Fixing spacer	Inner	1+1	1+1	1+1	1+1	1+1	1+1	1+1	1+1	1+1	1+1	1+1	1+1	1+1	1+1	1+1	1+1

125kg - 500kg

(Unit: piece)

Capacity (Plain trolley)	Parts name	Rail width (in)	1113/16	117/8	12
		Rail width (mm)	300	302	305
125kg 250kg 490kg 500kg	Thin spacer	Inner	4+4	4+5	1+5
		Outer	1	0	3
	Thick spacer	Inner	3+3	3+3	4+3
		Outer	1	1	0
	Thick spacer L	Inner	1+1	1+1	1+1
		Outer	0	0	0
	Fixing spacer	Inner	1+1	1+1	1+1

1t

(Unit: piece)

Capacity (Plain trolley)	Parts name	Rail width (in)	1113/16	117/8	12
		Rail width (mm)	300	302	305
1t	Thin spacer	Inner	4+4	4+5	1+5
		Outer	1	0	3
	Thick spacer	Inner	3+3	3+3	4+3
		Outer	1	1	0
	Thick spacer L	Inner	1+1	1+1	1+1
		Outer	0	0	0
	Fixing spacer	Inner	1+1	1+1	1+1

* Description for spacers;

For example, "0+1"

0: the number of spacers on the frame G side.

1: the number of spacers on the frame S side.

Rail width of 50 – 102 (mm) [125kg – 500kg]: Normal suspension shaft
58 – 127 (mm) [1t]Rail width of 103 – 305 (mm) [125kg – 500kg]: Wide-frange suspension
shaft (optional)

Ⓐ indicates standard range.

Ⓑ indicates W20 range, as option.

Ⓒ indicates W30 range, as option.

(t)	(in)	4	5	6	7	8
0.5						
1		Ⓐ		Ⓑ		Ⓒ

Assembling (continued)

For I beam

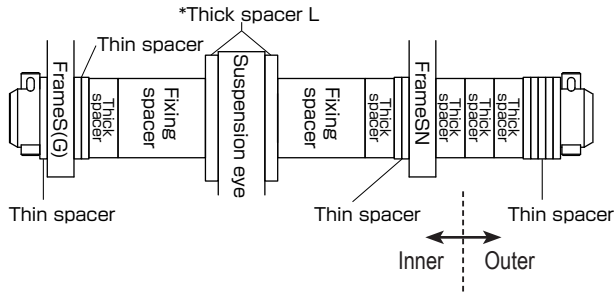

* When connecting with manual trolley, use the Thick spacer L provided in the package.

Length of Adjusting Spacer

(Unit: mm)

PT		125kg, 250kg, 490kg, 500kg	1t
Thin spacer	A	3.2	3.2
	B	31	35
	C	22.5	25.5
Thick spacer	A	12.5	12.5
	B	29.4	34
	C	23	27.6
Thick spacer L	A	5.5	3.2
	B	42.7	54
	C	22.7	26
Fixing spacer (200)	A	31.5	43
	B	29.4	34
	C	23	27.6
Fixing spacer (300)	A	81.5	80.5
	B	29.4	34
	C	23	27.6
Suspension shaft diameter		22	25

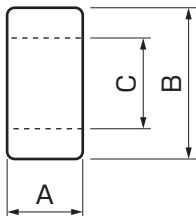

Thin spacer/Thick spacer/Thick spacer L/

Fixing spacer

■ Combination of the Electric Chain Hoist and the Manual Trolley

⚠ DANGER



Mandatory

- Use new split pins. After insertion, bend the pin securely at its both ends.
- Use of old split pins may result in death or serious injury due to drop.

● 125kg to 1t

1) After setting the Suspension Shaft with Spacers, insert it into Frame G or Frame S and fix it with a Shaft Stopper Pin and a Split Pin.

- Insert the Shaft Stopper Pin in the direction that the split pin comes to the right when viewed from the side of the Frame G or Frame S.
- Open the both ends of the Split Pin by 70° or more.

2) Set the Suspension Shaft with a Thick Spacer, Fixing Spacer, etc.

3) Passes it through the string the Suspension Eye.

4) Set the Suspension Shaft with another Thick Spacer and Fixing Spacer. Then insert the Suspension Shaft into the Frame SN.

- Adjust the Spacers in accordance with the rail width. (Refer to "Checking the Number of the Assembled Adjusting Spacers and Their Positions" (P43 to 45) for the number of Spacers.)

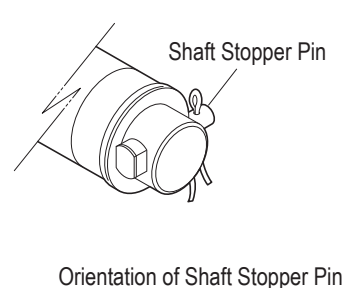
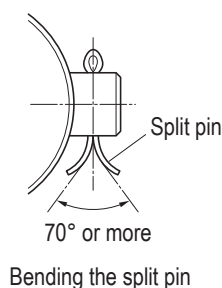
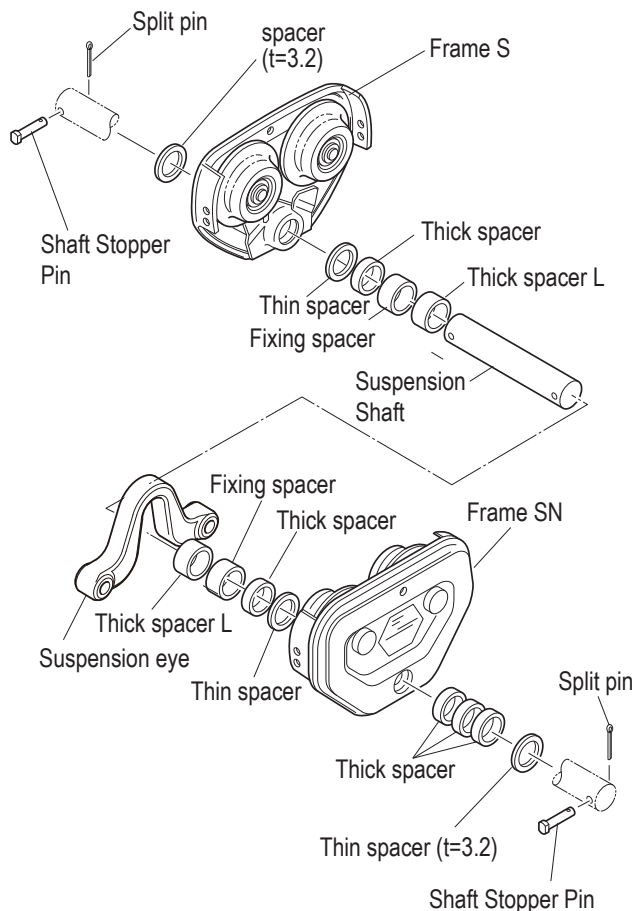

5) Set the Suspension Shaft with a Thick Spacer. Fix it with a Shaft Stopper Pin and a split pin.

- Insert the Shaft Stopper Pin in the direction that the split pin comes to the right when viewed from the front side of the Frame SN.
- Open the both ends of the Split Pin by 70° or more.



■ Checking Power and Power Cable

■ Checking the Power

 DANGER	
 Mandatory	<ul style="list-style-type: none"> • Check that the rating of the breaker satisfies the specification required by the electric chain hoist. • Check that the source voltage satisfies the rated voltage of the electric chain hoist. <p>Failure to comply with this instruction may result in death or serious injury.</p>

Hook Suspended Type: EQ



Manual trolley type: EQSP

Code	Minimum Wire size (mm ²)	Capacity of fuse and circuit breaker (A)	
		230V Class	400V Class
		Dual speed	Dual speed
EQ001IS	1.25	10	5
EQ003IS			
EQ005IS		15	10
EQ010IS			

Motorized trolley type: EQM

Code	Minimum Wire size (mm ²)	Capacity of fuse and circuit breaker (A)	
		230V Class	400V Class
		EQ Dual MR Dual	EQ Dual MR Dual
EQ001IS	2	15	10
EQ003IS			
EQ005IS		20	
EQ010IS			

■ Checking the Power Cable

 CAUTION	
 Prohibited	<ul style="list-style-type: none"> • Do not use the cable other than the cable attached to the main unit or optional Power Cable. <p>Failure to comply with this instruction causes bodily injury or loss of property.</p>
 Mandatory	<ul style="list-style-type: none"> • Satisfy the maximum permissible length and core cross section of the Power Cable. <p>Failure to comply with this instruction causes bodily injury or loss of property.</p>

Refer to the following table for the permissible length and the size of the standard Power Cable.

When using the cable of the size other than those described in the table, decide the cable length using the following formula.

$$\text{Permissible length (m)} = \frac{1000}{30.8} \times \frac{\text{Cross section of one core (mm}^2\text{)} \times \text{Rated voltage (V)} \times 0.02}{\text{Rated current (A)}}$$

Suspended Type: EQ

Manual Trolley Type: EQSP

EQ	Minimum wire size (mm ²)	Permissible length (m)			
		230V Class		400V Class	
		Dual speed		Dual speed	
		50Hz	60Hz	50Hz	60Hz
		220-230V		380-415V	380-440V
EQ001IS	1.25 (2)	35		110	
EQ003IS		(56)		(176)	
EQ005IS		28		93	
EQ010IS		(45)		(149)	
		17		56	
		(27)		(89)	

Motorized trolley type: EQM

EQ	Minimum wire size (mm ²)	Permissible length (m)			
		230V Class		400V Class	
		EQ Dual MR Dual		EQ Dual MR Dual	
		50Hz	60Hz	50Hz	60Hz
		220-230V		380-415V	380-440V
EQ001IS	2 (3.5)	33		93	
EQ003IS		(58)		(162)	
EQ005IS		29		85	
EQ010IS		(51)		(148)	
		20		61	
		(35)		(107)	

Note: Values in parenthesis shows the one size longer cable than normal.

■ Connecting Cables

NOTE

- When clamping a connector, do not use tools. Be sure to clamp it by hand.
Excessive tightening of a connector may result in the damage or breakage of plastic thread part.
- To prevent wire breakage and unintentional removal of a connector, tie the protection wire attached to the Push Button Switch Cord to the main unit of the electric chain hoist or the trolley.
Be sure to tie the cord with the body size or the trolley to prevent the wire breakage and removal of connector when the cord is pulled strongly.
- Be sure to turn off the power when carrying out the repair work of wire breakage or removal of the connector.

■ Suspended model (hoist only)

■ 125kg to 1t

● Connecting the Power Cable

- 1) Insert the Power Cable Holder A to the Holder B and tighten it securely.
- 2) Fix the Power Cable using cable holder with a slack.
- 3) Connect the Power Cable to the VFD terminals.
 - Refer to the connection diagram on the Controller cover and connect wires correctly

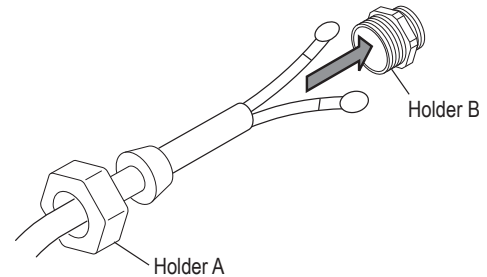

● Connecting the Push Button Switch Cord

- 1) Insert the Push Button Cord Holder A to the Holder B and tighten it securely

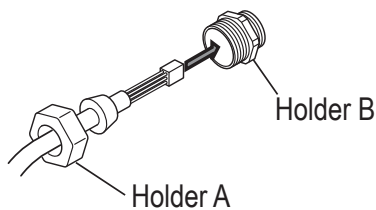

- 2) Pass the Cable Support L into the ring at the end of the Protection Wire. Put the Protection Wire in the notch of the Cable Support L.
Then fix the Cable Support L to the body size (at the bottom face of the Gear Case).

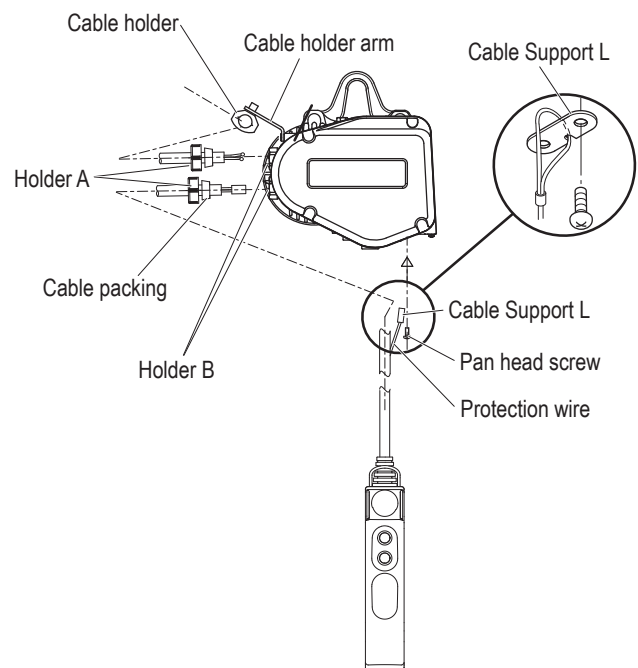

- 3) Insert the Push Button Connector (white) to the connector (white) on the right of HBB board inside the VFD.
 - Refer to the connection diagram on the Controller cover and connect wires correctly

■ Motorized Trolley Type

■ 125kg to 1t

● Connecting the Relay Cable for Power

- 1) Insert the Power Cable Holder A to the Holder B and tighten it securely.
- 2) Connect the Power Cable to the VFD terminals.
 - Refer to the connection diagram on the Controller cover and connect wires correctly

● Connecting the relay cable for operation

- 1) Insert the Push Button Cord Holder A to the Holder B and tighten it securely
- 2) Insert the Push Button Connector (white) to the connector (white) on the right of HBB board inside the VFD.
 - Refer to the connection diagram on the Controller cover and connect wires correctly

● Connecting the Trolley Power Cable

- 1) Remove the Holder A mounted to the Connection Box.
- 2) Pass the Power Cable through the Holder A supported by the cable holder and the cable packing.
- 3) Insert the Power Cable to the Holder B of the Connection Box and tighten the Holder A securely.
 - Trolley Type
 - Mount the cable holder, which the Power Cable is passed, to the cable holder arm using a chain hanging pin B, a slotted nut and a split pin.
- 4) Connect the Power Cable to the terminal panel of the Connection Box.
 - Connect wires correctly according to the wiring diagram affixed on the Connection Box.

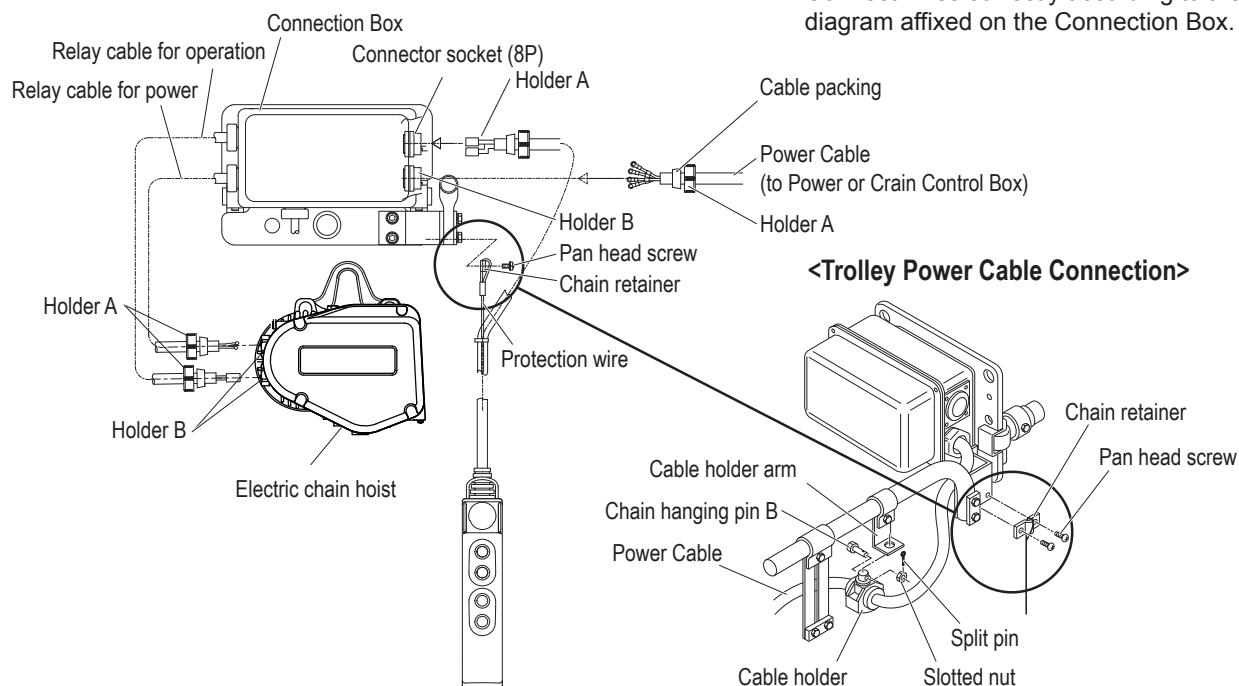

● Connecting the Trolley Push Button Cord

- 1) Insert the Holder A of the Relay cable for power to the Holder B and tighten it securely.
- 2) Refer to the connection diagram and connect wires correctly.

Assembling (continued)

Manual Trolley Type

125kg to 1t

● **Connecting the Power Cable**

1) **Insert the Power Cable Holder A to the Holder B and tighten it securely.**

2) **Fix the Power Cable using cable holder with a slack.**

3) **Connect the Power Cable to the VFD terminals.**
 • Refer to the connection diagram on the Controller cover and connect wires correctly

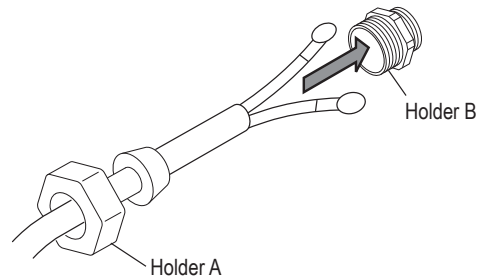

● **Connecting the Push Button Switch Cord**

1) **Insert the Push Button Cord Holder A to the Holder B and tighten it securely**

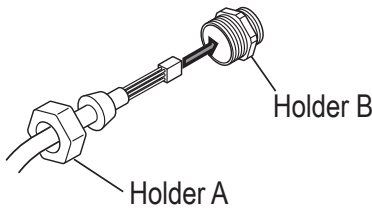

2) **Pass the Cable Support L into the ring at the end of the Protection Wire. Put the Protection Wire in the notch of the Cable Support L. Then fix the Cable Support L to the body size (at the bottom face of the Gear Case).**

3) **Insert the Push Button Connector (white) to the connector (white) on the right of HBB board inside the VFD.**

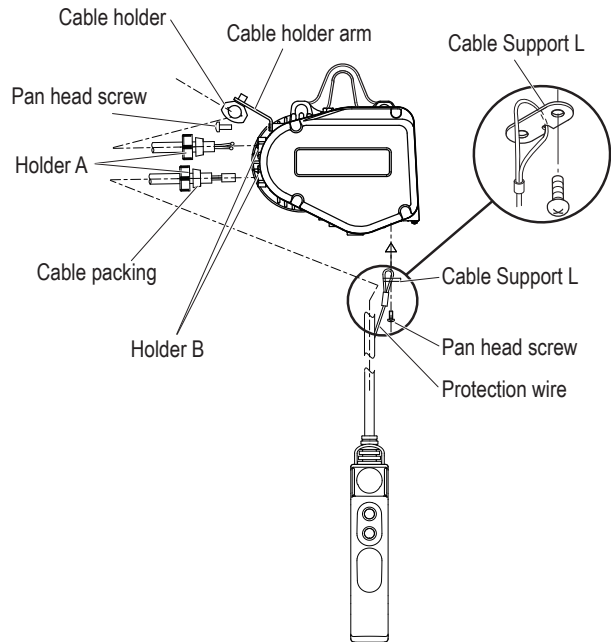

Installation

⚠ DANGER



Prohibited

- Do not install the electric chain hoist at a place exposed to rain or water always or the place different from the Operational Environment (P17).
- Do not install the electric chain hoist in the motion space of other trolley or any other moving equipment (facility).
- Do not use the electric chain hoist contacting with other object, or being fixed.

Failure to comply with these instructions may result in death or serious injury.



Mandatory

- **Installation (removal) of the electric chain hoist must be carried out by special installer or by personnel with expertise.**
Consult with the sales shop or KITO for installation, or consign the installation work to special installer or personnel with expertise.
- **When installing or removing the electric chain hoist, follow the instructions in Owner's Manual.**
- **Carry out the work for grounding (earthing) and installation of earth leakage breaker with higher harmonic countermeasures.**
These work must be carried out by an electric work specialist.
- **When the installation is completed, carry out "Check after Installation". (See P54)**
- **Connect the power after all installation works have been completed and just before the operation check.**
- **Mount the stopper at the both ends of the travel rail for trolley. <Fig. A>**
- **Make sure that the strength of the structure is sufficient to install the electric chain hoist.**
- **Carry out the installation work after securing the stable hoothold.**
- **Before building the electric chain host into part of your own travel device without using the standard trolley, contact us for information on precautions.**

Failure to comply with these instructions may result in death or serious injury.

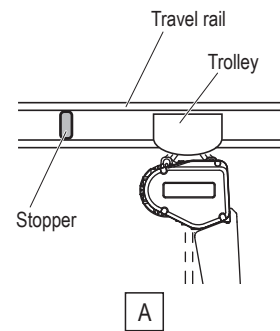

⚠ CAUTION



Mandatory

- **Connect the Power Cable to the power of rated voltage.**
Failure to comply with this instruction causes bodily injury or loss of property.

■ Connecting Power and Power Cable

When connecting the Power Cable to the power, connect the cable in accordance with the following instructions.

- Connect the electric chain hoist to the power through a breaker.
- Connect the electric chain hoist in the correct phase.
- Earth wire is a green colored covered cable with yellow line. Carry out Class D earthing work.
- Use correct breaker and Power Cable referring to Checking Power and Power Cable (P48, 49) for the breaker capacity, Power Cable length and its size.

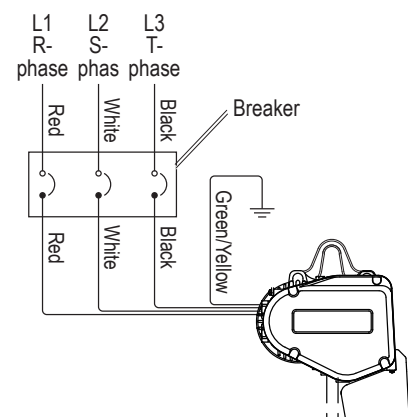

■ Installing the Suspended Type (hoist only)

■ Checking Installation Method and Place

⚠ DANGER



Mandatory

- **When using an electric chain hoist suspended (as a single unit), make sure that the Suspension Eye is installed and hooked securely.**
- **Install the electric chain hoist so that the Suspension Eye itself can swing freely. (Make sure not to restrain the Suspension Eye when in use.)**
- **Do not install and use the electric chain hoist upside down.**
- **The diameter of the Suspension Shaft hooked by Suspension Eye should be thinner than 31mm or less. Refer to the Suspension dimension (P38).**

Failure to comply with these instructions may result in death or serious injury.

■ Installing the Trolley Combined Model

■ Mounting the Hoist to the Travel Rail

- 1) Make sure that the dimensions of the Trolley Frame satisfy the size of the rail to which the trolley is installed.
- 2) Make sure that the rail is set to a level.
- 3) Install the electric chain hoist combined with the trolley to the rail from its one end

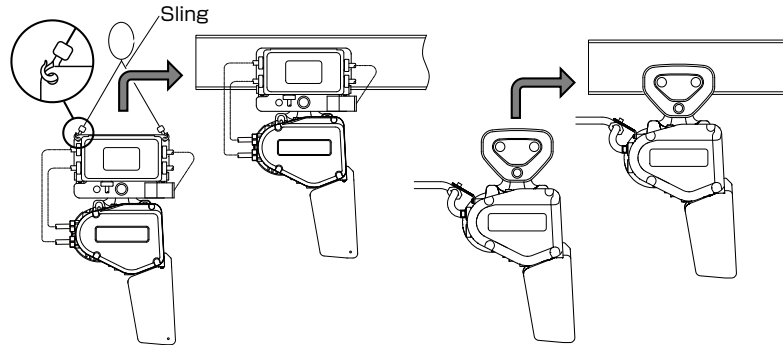

- When the gap between the rail end and the wall of the housing is scarce

⚠ CAUTION



Mandatory

- Securely support the electric chain hoist Mode EQ not to tilt.
Failure to comply with this instruction causes bodily injury or loss of property.

- 1) Assemble the Trolley temporarily using the hole B of the Lifting Shaft and install the electric chain hoist from the bottom side of the Travel Rail.
- 2) Set the wheel at Frame G side of the Trolley Frame on the running face of the Travel Rail. Then push the Frame S into the Frame G.
- 3) Insert the Shaft Stopper Pin into the Hole A of the Suspension Shaft. Then mount a split pin securely.

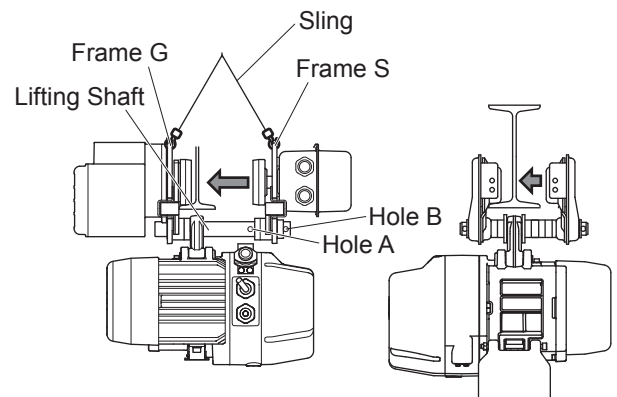

■ Mounting the Stopper

Be sure to mount the stoppers at the both ends of the rail to prevent drop.

Decide the mounting position in accordance to the size of the wheel.

When the customer wants to make the stopper by oneself, refer to the following figures.

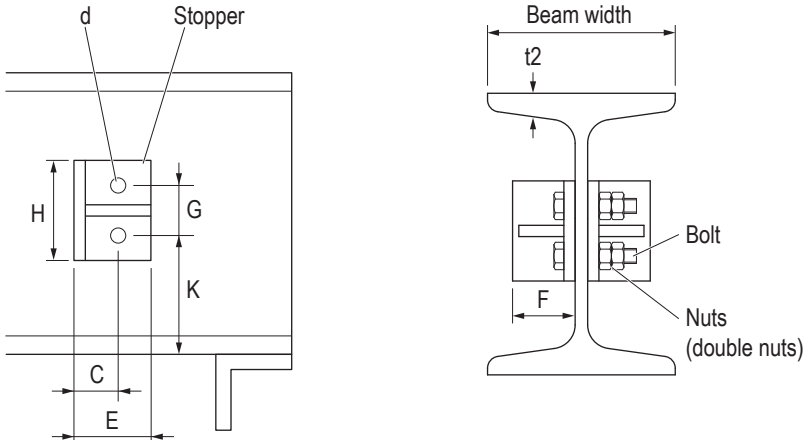

(Unit: mm)

Capacity	~1t			
Beam width	100	125	150	175
Material dimensions	L-50x50x6	L-50x50x6	L-65x65x8	L-75x75x9
H	80	80	80	80
E	50	50	65	75
F	40	50	65	75
G	50	50	50	50
C	30	30	35	40
K	65	t2+50	t2+50	t2+50
d	φ14	φ14	φ14	φ14
Bolt size	M12x50x50	M12x55x55	M12x55x55	M12x60x60

NOTE) Dimension K is for the case to use combining the hoist with the motorized trolley. When using the hoist combined with a manual trolley, mount the stopper in accordance with the bumper position.

● When using T-shape Suspender

Install the additional stopper for T-shape Suspender at the end of one rail.

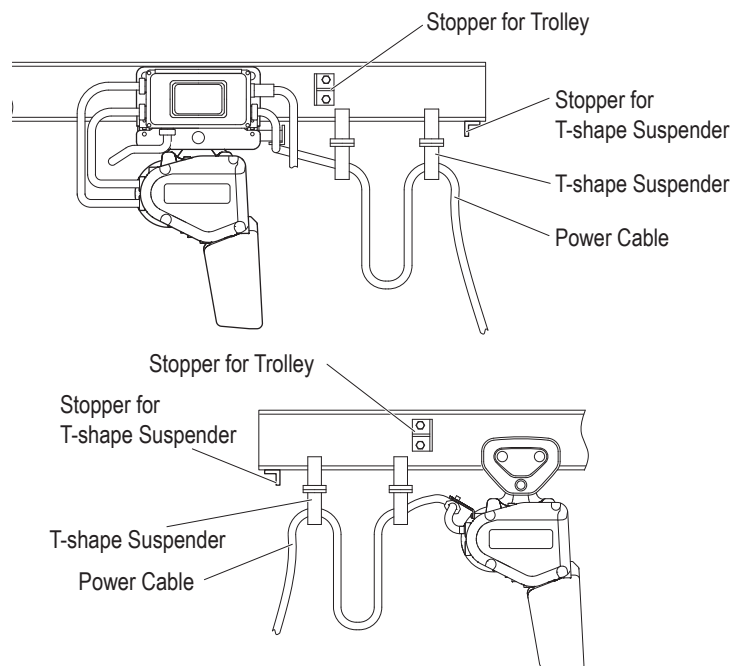

(to be continued)

Assembling (continued)

■ Power Cable Layout for Motorized/Manual trolley type

- In the standard specification the Suspenders are provided. T-shape Suspenders and angle type Suspenders are also available as optional parts. T-shape Suspenders can be applicable to curved rail, however, the application method differs depending on the condition such as radius of curvature. In such case, contact KITO.

1) Mount the wire support bar at the both ends of the rail.

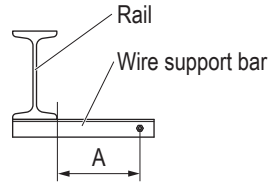

2) Tie the Messenger Wire passed through the Cable Hanger to the Wire Support Bar with two Wire Bolts.

- The recommended mounting interval of the Cable Hangers is 1.5 m to 2 m.
- Use steel wire of 3 to 6 mm in diameter for the Messenger Wire.

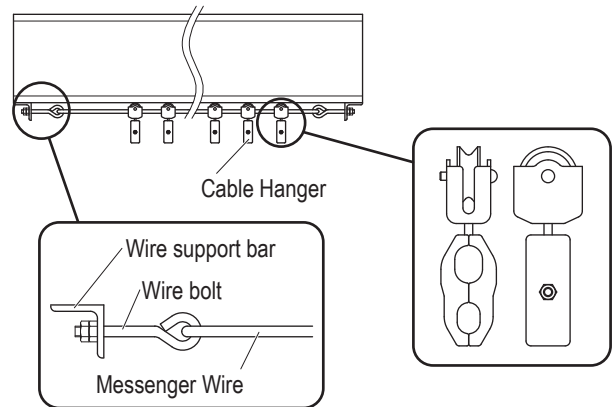

3) Loosen two pan head screws and remove the end clip of the wire guide.

4) Pass the Messenger Wire through the groove of the messenger guide. Mount the end clip with two pan head screws.

- The dimension A between the side face of the rail and the groove of the wire guide must be the same as that of the mounting hole of the Wire support bar for the Messenger Wire and the side face of the rail.

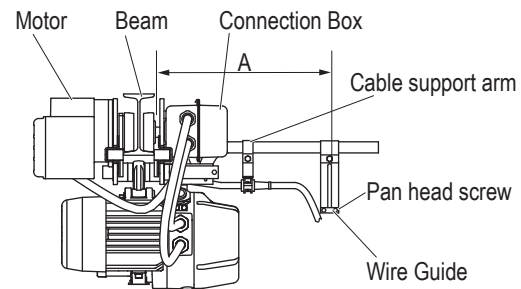

5) Fix the Power Cable to the Cable Hanger.

6) Mount the Cable Support to the Cable Support Arm.

7) Insert the Power Cable into the Connection Box of MR2Q and connect it to the terminal panel.

- Connect wires correctly according to the wiring diagram affixed on the Connection Box.

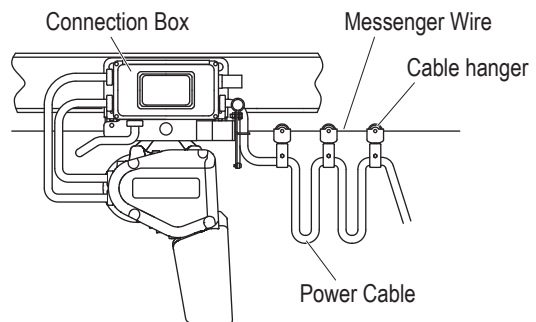

Check after Installation

Wrong assembling or installation causes death or serious injury. To prevent such danger check the following.

■ Check items

Make sure that the following are satisfied:

- No bolt, nut nor split pin is lost. Tightening and assembling are completed.
- Protection Wire for Push Button Switch Cord is securely tied to accept and endure the force instead of Push Button Switch Cord when the Push Button Switch Set is drawn.
- The Power Cable is fixed to the Cable Support.
- Source voltage is the rated voltage
- Grounding Wire (earth wire) is connected securely.

● When using with a Trolley

Check the following:

- The electric chain hoist and the trolley are combined correctly.
- The stoppers for trolley are securely mounted to Travel Rail where the Trolley travels.
- The surface of Travel Rail is not attached with paint or oil. (The surface of the Travel Rail must be basis metal. Do not paint.) There is no obstacle for the trolley to travel. The Travel Rail is set to a level.

■ Operational Check

Carry out the operational check in accordance with Daily inspection (P19).

Chapter 2

Inspection

This chapter describes frequent inspection items and periodic inspection items. Refer to Chapter 1 for the “Handling the Product”. Inspection is the first step of safety. Carry out daily inspection, frequent inspection and periodic check.

Table of Contents	60
--------------------------------	-----------

Table of Contents

■ Safety Precautions	62	■ Periodic Inspection	
■ Frequent Inspection		(Carry out the periodic inspection after check of no abnormality in daily inspection and frequent inspection items.)	
(Carry out the frequent inspection after check of no abnormality in daily inspection items.)		■ Electric Chain Hoist (EQ) Periodic Inspection	
■ Electric Chain Hoist (EQ) Frequent Inspection		Suspension Eye, Bottom Hook	
Load Chain		Number of start	72
Elongation of Pitch	65	Peripheral parts of the Body size	
Abrasion of wire diameter	65	Chain Guide	72
Suspension Eye, Bottom Hook		Chain Spring	73
Opening and Abrasion of the Hook, Abrasion of the Suspension eye	66	Stopper	73
Deformation, Flaw, Corrosion	66	Limit Switch Cover	73
Peripheral parts of the Body size		Oil	
Chain Container	67	Oil Leakage	74
Electromagnetic Brake		Oil amount and stain	74
Number of start	67	Electromagnetic Brake	
Push Button Switch		Brake	75
Push Button Switch Body size	68	Driving Mechanism	
Push Button Switch Cord	68	Bearing	76
Power Supply		Load Gear, Gear 2, Gear 3, Motor Shaft	76
Power Cable	69	Friction Clutch	76
Cable Hanger	69	Abrasion and flaw of the Load Sheave	77
Messenger Wire	69	Electrical Equipment	
Function and Performance		Electrical Parts	78
Abnormal Noise	69	Wiring	78
Motorized Trolley (MR2Q) Frequent Inspection		Contamination and attachment of foreign matter ...	78
Appearance		VFD	78
Travel Rail	70	Electric Characteristics Measurement	
Oiling (to the gears of wheel)	70	Source Voltage	78
Push Button Switch, Power Supply	70	Insulation Resistance	78
(Refer to Electric Chain Hoist (EQ) Frequent Inspection)		Grounding Resistance	79
Manual Trolley (TS2) Frequent Inspection		Function and Performance	
Appearance		Operational Check	79
Combination	70	Brake	79
Travel Rail	70		
Oiling (to the gears of wheel)	70		

■ Motorized Trolley (MR2Q) Periodic Inspection

Brake

Appearance	80
Abrasion of Brake Pad.....	80

Body size Components

Wheel	80
Side Roller	80
Lifting Shaft	81
Gear Frame Packing	81
Gears and Motor Shaft	81
Suspension Eye	81

Travel Rail

Rail Surface	82
Deformation and Abrasion	82
Rail Mounting Bolt	82
Stopper	82

Relay Cable

Appearance	82
------------------	----

Electrical Equipment and Electric Characteristics ... 82

Function and Performance

Operational Check	83
Brake	83
Abnormal Noise	83

■ Manual Trolley (TSP) Periodic Inspection

Body size Components

Wheel	84
Lifting Shaft	84
Suspension Eye	84

Travel Rail

Rail Surface	84
Deformation and Abrasion	85
Rail Mounting Bolt	85
Stopper	85

Function and Performance

Operational Check	85
Abnormal Noise	85

■ Guidelines for Parts Replacement based on Indication of CH Meter

Guidelines and Precautions on Gear Oil Change Cycle ...	86
Guidelines for Checking Brake	86
Guidelines on Gear Parts Replacement (Load Gear, Friction clutch with Gear 2, Gear 3) ...	87
Guidelines on Motor Shaft (with Rotor) Replacement ...	87
Guidelines on Bearing Replacement	87
Guidelines on Hook, Yoke and Suspension Eye Replacement.....	87

■ Check of Operating Hours and Number of Start (CH Meter)

Start Times/Operating Hour Display Device.....	88
The display contents of the number of start and operating hours.....	88
Displaying of the numbers of start and operating hours	88
Calculating the number of start.....	89
Converting the operating hours	89

● Reference

Daily inspection is described in Chapter 1 “How to Use the Product”. Refer to the following daily inspection items and their relevant pages.

■ Daily Inspection of Electric Chain Hoist (EQ Type)

Appearance

Indication of Nameplates and Labels	19
Deformation and damage of main unit and each part ...	19
Loosened or fallen off bolts, nuts and split pins ...	19

Load Chain

Elongation of Pitch	20
Abrasion of Wire Diameter	20
Deformation, Flaw, Entanglement	20
Rust, Corrosion	20
Lubrication	20
Mark	20

Suspension Eye / Bottom Hook

Opening of the Hook	21
Abrasion	21
Deformation, Flaw, Corrosion	21
Hook Latch	21
Hook movement (Rotation)	21
Bottom Yoke.....	22

Peripheral parts of the body size

Bottom Yoke.....	22
------------------	----

Push Button Switch

Switch body size	22
------------------------	----

Function and Performance

Operational Check	23
Brake	23
Limit Switch	23
Check for no Abnormal Sound	23

Daily Inspection of Motorized Trolley (EQM)

Appearance

Indication of Nameplates and Labels	24
Deformation and damage of each part	24
Loosened or fallen off bolts, nuts and split pins ...	24

Function and Performance

Operational Check	24
Brake	24

■ Daily Inspection of Manual Trolley (EQSP)

Appearance

Indication of Nameplates and Labels	25
Deformation and damage of each part	25
Loosened or fallen off bolts, nuts and split pins ...	25

Function and Performance

Operational Check	25
-------------------------	----

Safety Precautions

General Matters related to Inspection

DANGER



Prohibited

- **Do not use the part exceeding the service limit or criteria and the parts other than genuine part for KITO electric chain hoist.**
Even if the part is genuine KITO part, it cannot be used for other model. Refer to Disassembly/Assembly Manual (Annex) for the correct use of the part.
- **Do not adjust or disassemble the Brake or Friction Clutch.**
- **Do not adjust the set nut.**
- **Do not carry out the inspection of electric chain hoist with a lifted load.**
- **Do not use the electric chain hoist removing the chain spring and the stopper.**
- **Turn off the main power when carrying out the inspection.**

Failure to comply with these instructions may result in death or serious injury.



Mandatory

- **Be sure to carry out the frequent and periodic inspection.**
- **Periodic inspection of the electric chain block must be performed by maintenance engineer.**
- **When oiling the Friction Clutch, use KITO genuine oil (manufacturer specified oil).**
- **When using oils such as gear oil and grease, avoid places with fire or sparks.**
- **Put the electric chain hoist on the floor or work bench when performing the repair and disassembling of the electric chain hoist.**
- **Even if each component of the electric chain hoist does not exceed the service limit, replace the part exceeding the total operating hours derived from the grade indicated on the electric chain hoist and the load factor.**
- **Do not use the electric chain hoist when any abnormality was observed during the inspection. Indicate "FAILURE" on the hoist and contact with maintenance engineer or KITO for repair.**
- **After completion of the inspection (frequent, periodic), perform the functional check and make sure that the electric chain hoist operates correctly.**
- **When performing the functional check, be sure to perform the capacity test after no load test.**

Failure to comply with these instructions may result in death or serious injury.

CAUTION



Mandatory

- **Indicate "CHECKING" when performing the inspection.**
When a crane is operated erroneously during the inspection, it may result in the accident such as fall-off of parts and tools and downfall.
- **Wear protection equipment such as protection goggles and gloves depending on the work contents.**
Otherwise it may result in the injury due to scattered oil or sharp edge of a part.
- **Pay attention to work method, work procedure and work posture.**
If the product or the part is heavy, your hand is caught or your waist is hurt.
Especially be careful for the work on an unstable scaffold such as the work at high lifted place using stepladder.
- **Wear helmet and safety belt when carrying the high lift work.**
Otherwise it may result in injury or downfall accident.
- **Remove the oil attached to the product or spilt on the floor.**
Otherwise it may result in injury due to drop of the product or overturning.
- **Keep the work area clean when disassembling the product.**
Assembling or mixing the part other than genuine part may result in the damage of the product or the accident due to defective operation.

NOTE

- When performing the frequent inspection, carry out the daily inspection at the same time.
- When performing the periodic inspection, carry out the frequent inspection and the daily inspection at the same time.
- When detecting any abnormality during inspection due to erroneous use, instruct the operator and user for correct use of the electric chain hoist.

Ex. (1) The flaw on the Chain Guide hit with the Chain (Cause: lifting incline)

(2) The deformation of the Chain Spring (Cause: excessive use of the limit switch)

Frequent Inspection

General Matters on Frequent Inspection

DANGER



Mandatory

- After completion of the frequent inspection, perform the functional check and make sure that the electric chain hoist operates correctly.

Neglecting to perform the functional check may result in death or serious injury.

General Matters on Handling the Model EQ Electric Chain Hoist

The Model EQ Electric Chain Hoist is controlled by the VFD for important items related to safety such as operation, braking and emergency stop. Be sure to follow the safety precautions below as well as the above safety precautions.

DANGER



Prohibited

- **Do not disassemble the Model EQ Electric Chain Hoist in the same way as the contactor system.**
- **Do not change the VFD parameter.**
When parameters need to be changed, ask our distributors nearest to the customer or KITO.
- **Do not carry out the work such as maintenance and inspection within 5 minutes after power off.**
Wait for the completion of discharging of the capacitor inside the VFD.
- **USE KITO genuine VFD.**
The VFD requires the special specification for KITO. Be sure to use genuine VFD.
- **Do not change the connection of the VFD.**
When the wires were removed for any reason, connect them again correctly checking the wiring diagram inside the controller cover.
- **Do not carry out withstand voltage test of a circuit while the VFD is connected.**
- **Do not turn off the power while operating.**

Failure to comply with these instructions may result in death or serious injury and the damage of VFD.



Mandatory

- **USE KITO genuine VFD.**
The VFD requires the special specification for KITO. Be sure to use genuine VFD.

Failure to comply with this instruction may result in death or serious injury.

NOTE

When performing the frequent inspection, carry out the daily inspection at the same time.

- Check the electric chain hoist as installed, standing on the floor.

■ Electric Chain Hoist (EQ) Frequent Inspection

■ Load Chain

- Check the Load Chain after removing the stain on the chain.
- Use the needle head caliper (point caliper) to measure the sum of pitches and wire diameter.
- Apply oil on the Load Chain after inspection.
- Application of lubricant influences on the life of the Load Chain considerably. Use the KITO genuine lubricant or equivalent (industrial lithium grease: consistency No.0)
- Release all loads from the Load Chain. Apply the lubricant to the linking portion of the Load Chain that engages the Load Sheave and the linking portion of the Load Chain.
- After application of the lubricant, lift/lower the electric chain hoist without load to spread the lubricant on the Load Chain.

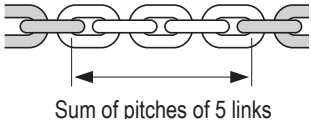
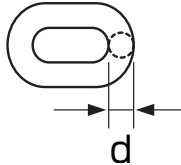
Item	Check method	Criteria	When failed
Elongation of Pitch	<ul style="list-style-type: none"> • Measure the elongation of pitch with point caliper. (Measure the sum of pitches of 5 links) 	<p style="text-align: center;">NOTE</p> <p>Check the engaging point of the Load Sheave especially carefully.</p> <ul style="list-style-type: none"> • The limit value of the following “Sum of pitches of five links” must not be exceeded. 	Replace the Load Chain.
Abrasion of wire diameter	<ul style="list-style-type: none"> • Measure the wire diameter (d) with point caliper. 	<ul style="list-style-type: none"> • The limit value of the following “Wire diameter of the Load Chain” must not be exceeded. <p style="text-align: center;">NOTE</p> <p>When the abrasion of the Load Chain is observed, be sure to check the abrasion of the Load Sheave also. (Refer to “Periodic Inspection”, “Load Sheave” (P77).)</p>	Replace the Load Chain.

Load Chain Pitch and Wire Diameter for Each Capacity

Code	Capacity	Load Chain diameter (mm)	Sum of 5 Links (mm)		Load Chain diameter (mm)
			Do not exceed the limit		Do not fall under the limit
			Standard	Limit	Limit
EQ001IS	125kg	φ5.6	79	81.5	5.1
EQ003IS	250kg				
EQ004IS	490kg				
EQ005IS	500kg				
EQ010IS	1t	φ7.1	100	103	6.4



Frequent Inspection (continued)

■ Suspension Eye, Bottom Hook

Item	Check method	Criteria	When failed																																																																									
Opening and Abrasion of the Hook Abrasion of the Suspension eye	<ul style="list-style-type: none"> Check visually and measure with vernier caliper. 	<div style="border: 1px solid black; padding: 5px;"> <p>⚠ CAUTION</p> <p>! Mandatory</p> <ul style="list-style-type: none"> Compare the dimensions of a, b and c with those at purchasing. Check that they are within the criteria. <p>The use of the Hooks with these dimensions exceeding the criteria may result in bodily injury or property damage.</p> </div> <table border="1" style="margin-top: 10px;"> <thead> <tr> <th colspan="2">Measured value (mm)</th> <th>Limit value</th> </tr> </thead> <tbody> <tr> <td rowspan="3">Bottom Hook</td> <td>Dimension a</td> <td>Not to exceed the dimension at purchasing</td> </tr> <tr> <td>Dimension b</td> <td rowspan="3">Abrasion not to exceed 5%</td> </tr> <tr> <td>Dimension c</td> </tr> <tr> <td>Suspension Eye</td> <td>Dimension d</td> </tr> <tr> <td></td> <td>Dimension e</td> <td></td> </tr> </tbody> </table> <ul style="list-style-type: none"> Following tables shows the nominal standard values. Please be aware that these values include tolerance because of forging. <p>Guidelines on the Hook and Suspension Eye (refer to P87) or its criteria</p> <table border="1" style="margin-top: 10px;"> <thead> <tr> <th rowspan="3">Code</th> <th rowspan="3">Capacity</th> <th colspan="5">Bottom Hook</th> <th colspan="4">Suspension Eye</th> </tr> <tr> <th colspan="2">Dimension a (mm)</th> <th colspan="2">Dimension b (mm)</th> <th colspan="2">Dimension c (mm)</th> <th colspan="2">Dimension d (mm)</th> <th colspan="2">Dimension e (mm)</th> </tr> <tr> <th>Standard</th> <th>Limit value</th> <th>Standard</th> <th>Limit value</th> <th>Standard</th> <th>Limit value</th> <th>Standard</th> <th>Limit value</th> <th>Standard</th> <th>Limit value</th> </tr> </thead> <tbody> <tr> <td>EQ001IS</td> <td>125kg</td> <td rowspan="4">45.0</td> <td rowspan="4">17.5</td> <td rowspan="4">16.6</td> <td rowspan="4">23.5</td> <td rowspan="4">22.3</td> <td rowspan="4">8.0</td> <td rowspan="4">7.6</td> <td rowspan="4">16.0</td> <td rowspan="4">15.2</td> </tr> <tr> <td>EQ003IS</td> <td>250kg</td> </tr> <tr> <td>EQ004IS</td> <td>490kg</td> </tr> <tr> <td>EQ005IS</td> <td>500kg</td> </tr> <tr> <td>EQ010IS</td> <td>1t</td> <td>50.0</td> <td>22.5</td> <td>21.4</td> <td>31.0</td> <td>29.5</td> <td>12.3</td> <td>11.7</td> <td>22.0</td> <td>20.9</td> </tr> </tbody> </table>	Measured value (mm)		Limit value	Bottom Hook	Dimension a	Not to exceed the dimension at purchasing	Dimension b	Abrasion not to exceed 5%	Dimension c	Suspension Eye	Dimension d		Dimension e		Code	Capacity	Bottom Hook					Suspension Eye				Dimension a (mm)		Dimension b (mm)		Dimension c (mm)		Dimension d (mm)		Dimension e (mm)		Standard	Limit value	Standard	Limit value	Standard	Limit value	Standard	Limit value	Standard	Limit value	EQ001IS	125kg	45.0	17.5	16.6	23.5	22.3	8.0	7.6	16.0	15.2	EQ003IS	250kg	EQ004IS	490kg	EQ005IS	500kg	EQ010IS	1t	50.0	22.5	21.4	31.0	29.5	12.3	11.7	22.0	20.9	Replace the Hook and Suspension eye.
Measured value (mm)		Limit value																																																																										
Bottom Hook	Dimension a	Not to exceed the dimension at purchasing																																																																										
	Dimension b	Abrasion not to exceed 5%																																																																										
	Dimension c																																																																											
Suspension Eye	Dimension d																																																																											
	Dimension e																																																																											
Code	Capacity	Bottom Hook					Suspension Eye																																																																					
		Dimension a (mm)		Dimension b (mm)		Dimension c (mm)		Dimension d (mm)		Dimension e (mm)																																																																		
		Standard	Limit value	Standard	Limit value	Standard	Limit value	Standard	Limit value	Standard	Limit value																																																																	
EQ001IS	125kg	45.0	17.5	16.6	23.5	22.3	8.0	7.6	16.0	15.2																																																																		
EQ003IS	250kg																																																																											
EQ004IS	490kg																																																																											
EQ005IS	500kg																																																																											
EQ010IS	1t	50.0	22.5	21.4	31.0	29.5	12.3	11.7	22.0	20.9																																																																		
Deformation, Flaw, Corrosion	<ul style="list-style-type: none"> Check visually. 	<ul style="list-style-type: none"> No deformation such as bend or twist No deep cut No loosened bolt or nut, or their fall off No considerable corrosion No attachment of foreign matter such as sputter 	Replace the Hook.																																																																									

■ Peripheral parts of the Body size

- Use check stand to check the electric chain hoist from the close point.

Item	Check method	Criteria	When failed
Chain Container	<ul style="list-style-type: none"> • Check visually. 	<ul style="list-style-type: none"> • To be mounted to the body size securely • No damage, tear, abrasion or deformation • Check no foreign matter inside the Chain Container. * Especially be careful when the electric chain hoist is used outdoor. • Make sure that the lift of the Load Chain is smaller than the capacity of the Chain Container. <div style="border: 1px solid black; padding: 5px; margin-top: 10px;"> <p style="text-align: center;">⚠ DANGER</p> <div style="display: flex; justify-content: space-between;"> <div style="text-align: center;">  <p>Prohibited</p> </div> <div> <ul style="list-style-type: none"> • Do not use the torn Chain Container. <p>Otherwise it may result in death or serious injury due to drop of the Load Chain.</p> </div> </div> <hr/> <div style="display: flex; justify-content: space-between;"> <div style="text-align: center;">  <p>Mandatory</p> </div> <div> <ul style="list-style-type: none"> • Use the Chain Container with the capacity larger than the lift of the Load Chain. <p>Otherwise it may result in death or serious injury due to drop of the Load Chain.</p> </div> </div> </div>	<p>Replace the Chain Container.</p> <p>Discard the foreign matter in the Chain Container.</p> <p>Replace the Chain Container with the adequate Chain Container referring to “Mounting the Chain Container”(P35).</p>

■ Electromagnetic Brake

Item	Check method	Criteria	When failed
Number of start	<ul style="list-style-type: none"> • Check the number of start with the CH Meter. 	<ul style="list-style-type: none"> • The number of start must be less than one million times. * Estimate the time to reach at one million times. 	<p>Perform the inspection in accordance with “Displaying the numbers of start and the operating hours” (P88).</p>

(to be continued)

Frequent Inspection (continued)

■ Push Button Switch

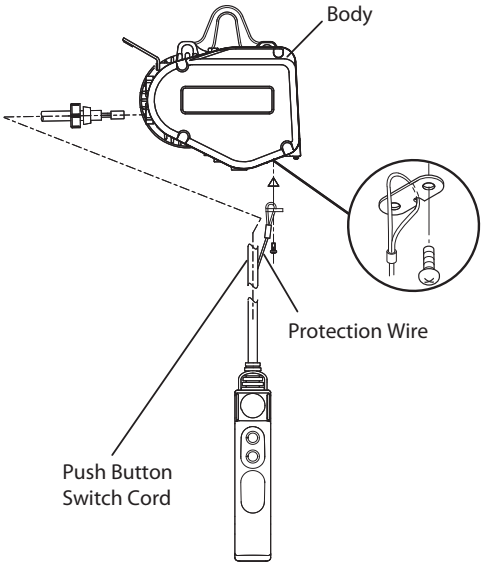
Item	Check method	Criteria	When failed
Push Button Switch Body size	<ul style="list-style-type: none"> Check visually and by operation. 	<ul style="list-style-type: none"> No damage, deformation and loosened bolt. Push Button Switches can be operated smoothly. Emergency Stop Button can be operated and cancelled. 	Replace the Push Button Switch.
Push Button Switch Cord	<ul style="list-style-type: none"> Check visually. 	<ul style="list-style-type: none"> Push Button Switch Cord is securely connected. The Protection Wire is tied with the body size so that Push Button Switch Cord is not strained directly even if the Push Button Switch is pulled. <hr/> <ul style="list-style-type: none"> To have no damage 	Tie the Push Button Switch Cord and the Protection Wire to the body size properly. Replace the Push Button Switch Cord.

■ Power Supply

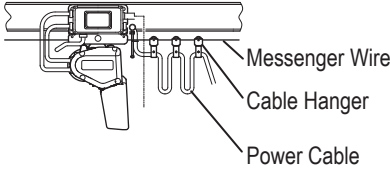
Item	Check method	Criteria	When failed
Power Cable	<ul style="list-style-type: none"> Check visually. 	<ul style="list-style-type: none"> Power Cable to have enough length. To have no damage To be connected securely 	Replace the Power Cable.
Cable Hanger	<ul style="list-style-type: none"> Check visually and by moving by hand. 	<ul style="list-style-type: none"> To have no damage To move smoothly To be mounted at equal interval ... Appropriate interval 1.5 m 	Re-mount the Cable Hangers for no hindrance to cable motion.
Messenger Wire	<ul style="list-style-type: none"> Check visually. 	<ul style="list-style-type: none"> To have no sag 	Remove the sag.

■ Function and Performance

- Check the following item with no load.

Item	Check method	Criteria	When failed
Abnormal Noise	<ul style="list-style-type: none"> Check the noise of gear, motor and the Load Chain during operation with no load. <div style="border: 1px solid black; padding: 5px; margin-top: 10px;"> <p style="text-align: center;">NOTE</p> <p>Sound is also an important check point. Always be careful for the noise of the electric chain hoist.</p> </div>	<ul style="list-style-type: none"> To sound no irregular rotating noise To sound no howling of motor and scraping sound of the Brake To sound no abnormal noise 	Replace the abnormal part.
		<ul style="list-style-type: none"> To sound no popping sound from the Load Chain 	Check the Load Chain. (Refer to P65.)

(to be continued)

Frequent Inspection (continued)**Motorized Trolley (MR2Q) Frequent Inspection****Appearance**

Item	Check method	Criteria	When failed
Travel Rail	<ul style="list-style-type: none"> Check visually. 	<ul style="list-style-type: none"> To have no considerable deformation and damage 	Check items in accordance with "Travel Rail" described in Chapter 2 "Periodic Inspection". (P82)
Oiling (to the gears of wheel)	<ul style="list-style-type: none"> Check visually. 	<ul style="list-style-type: none"> To be oiled adequately 	Apply oil to gears.

Push Button Switch, Power Supply

Carry out the inspection referring to "Frequent Inspection Items" of the electric chain hoist (EQ). (P68, 69)

Manual Trolley (TS2) Frequent Inspection**Appearance**

Item	Check method	Criteria	When failed
Combination	<ul style="list-style-type: none"> Shake the manual trolley to check. 	<ul style="list-style-type: none"> The motorized trolley shakes lightly to right and left. 	Combine the electric chain hoist and the manual trolley securely.
Travel Rail	<ul style="list-style-type: none"> Check visually. 	<ul style="list-style-type: none"> To have no considerable deformation and damage 	Check items in accordance with "Travel Rail" described in Chapter 2 "Periodic Inspection". (P82)
Oiling (to the gears of wheel)	<ul style="list-style-type: none"> Check visually. 	<ul style="list-style-type: none"> To be oiled adequately 	Apply oil to gears.

Periodic Inspection

■ General Matters on Periodic Inspection

⚠ DANGER



Mandatory

- **Put the electric chain hoist on the floor or work bench when inspecting the electric chain hoist.**
- **After completion of the periodic inspection, perform the functional check and make sure that the electric chain hoist operates correctly.**
 - Wear insulating gloves when measuring voltage.
 - When measuring the electric characteristics (insulation resistance, but except voltage measurement), turn off the power.

Failure to comply above instructions may result in death or serious injury.

■ General Matters on Handling the Model EQ Electric Chain Hoist

The Model EQ Electric Chain Hoist is controlled by the VFD for important items related to safety such as operation, braking and emergency stop. Be sure to follow the safety precautions below as well as the above safety precautions.

⚠ DANGER



Prohibited

- **Do not disassemble the Model EQ Electric Chain Hoist in the same way as the contactor system.**
- **Do not change the VFD parameter.**
When parameters need to be changed, ask our distributors nearest to the customer or KITO.
- **Do not carry out the work such as maintenance and inspection within 5 minutes after power off.**
Wait for the completion of discharging of the capacitor inside the VFD.
- **USE KITO genuine VFD.**
The VFD requires the special specification for KITO. Be sure to use genuine VFD.
- **Do not change the connection of the VFD.**
When the wires were removed for any reason, connect them again correctly checking the wiring diagram inside the controller cover.
- **Do not carry out withstand voltage test of a circuit while the VFD is connected.**
- **Do not turn off the power while operating.**

Failure to comply with these instructions may result in death or serious injury and the damage of VFD.



Mandatory

- **USE KITO genuine VFD.**
The VFD requires the special specification for KITO. Be sure to use genuine VFD.

Failure to comply with this instruction may result in death or serious injury.

NOTE

When performing the periodic inspection, carry out the daily inspection at the same time.

- Disassemble the electric chain hoist and check that it is assembled correctly without abnormal parts.

Periodic Inspection (continued)

■ Electric Chain Hoist (EQ) Periodic Inspection

■ Suspension Eye, Bottom Hook

Item	Check method	Criteria	When failed
Number of start	<ul style="list-style-type: none"> Check the number of start with the CH Meter. 	<ul style="list-style-type: none"> Number of start must not exceed the guidelines for replacement. 	Replace the Suspension Eye and Bottom Hook.

■ Peripheral parts of the Body size

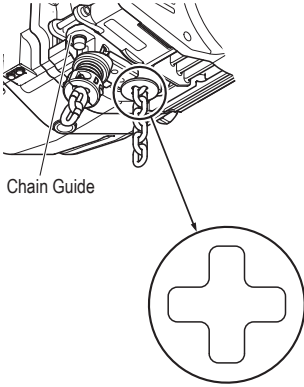
Item	Check method	Criteria	When failed
Chain Guide	<ul style="list-style-type: none"> Check visually.  <p>Chain Guide</p>	<ul style="list-style-type: none"> To have no apparent abrasion, deformation and damage To have no flaw due to hitting by the Load Chain <div style="border: 1px solid black; padding: 5px; margin-top: 10px;"> <p style="text-align: center;">⚠ CAUTION</p> <p>! Mandatory</p> <ul style="list-style-type: none"> The flaw due to hitting is caused by wrong use such as lifting a load in an inclined direction. If the abrasion is observed on the Chain Guide, the Load Chain may be worn also. Refer to the item of Load Chain Abrasion and check the abrasion. <p>Neglecting the check of the Load Chain abrasion may result in bodily injury or property damage.</p> </div>	Replace the Chain Guide.

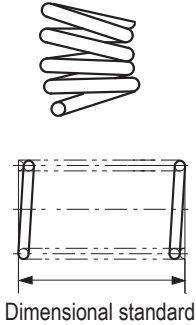
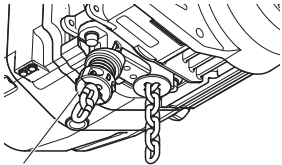
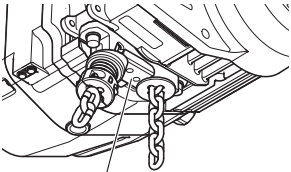
Item	Check method	Criteria	When failed																
<p>Chain Spring</p>	<ul style="list-style-type: none"> Check visually and measure the dimensions.  <p>Dimensional standard</p>	<ul style="list-style-type: none"> Check visually to have no apparent setting (deformation). <div style="border: 1px solid black; padding: 5px; margin: 10px 0;"> <p style="text-align: center;">CAUTION</p> <p>! Mandatory</p> <ul style="list-style-type: none"> The deformation of the Chain Spring is caused by excessive use of the Friction Clutch and the Limit Switch. Operate the electric chain hoist properly. <p>Otherwise it may result in bodily injury or property damage.</p> </div> <p>Service Limit of Chain Spring for Capacity (Do not fall short of the limit value.)</p> <table border="1" data-bbox="646 864 1169 1189"> <thead> <tr> <th rowspan="2">Code</th> <th rowspan="2">Capacity</th> <th colspan="2">Length of Chain Spring (mm)</th> </tr> <tr> <th>Standard</th> <th>Limit value</th> </tr> </thead> <tbody> <tr> <td>EQ004IS</td> <td>490kg</td> <td rowspan="2">29</td> <td rowspan="2">26.5</td> </tr> <tr> <td>EQ005IS</td> <td>500kg</td> </tr> <tr> <td>EQ010IS</td> <td>1t</td> <td>26.5</td> <td>24</td> </tr> </tbody> </table>	Code	Capacity	Length of Chain Spring (mm)		Standard	Limit value	EQ004IS	490kg	29	26.5	EQ005IS	500kg	EQ010IS	1t	26.5	24	<p>Replace the Chain Spring.</p>
Code	Capacity	Length of Chain Spring (mm)																	
		Standard	Limit value																
EQ004IS	490kg	29	26.5																
EQ005IS	500kg																		
EQ010IS	1t	26.5	24																
<p>Stopper</p>	<ul style="list-style-type: none"> Check visually.  <p>Stopper</p>	<ul style="list-style-type: none"> The stopper must be attached securely at the third link from the no load end of the Load Chain. 	<p>Attach the Stopper at the third link.</p>																
<p>Limit Switch Cover</p>	<ul style="list-style-type: none"> Check visually. 	<ul style="list-style-type: none"> To have no deformation, damage and abrasion To have no stain  <p>Limit Switch Cover</p>	<p>Replace the Limit Switch Cover. Disassemble the Limit Switch Cover and clean it.</p>																

Periodic Inspection (continued)

■ Oil

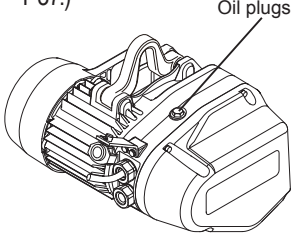
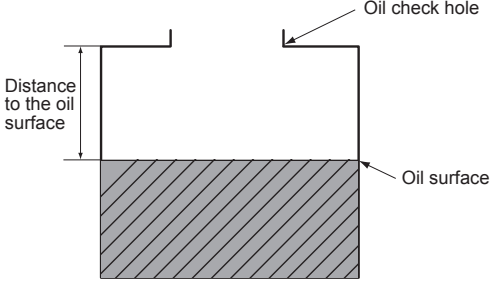
Item	Check method	Criteria	When failed
Oil Leakage	<ul style="list-style-type: none"> Check visually. 	<ul style="list-style-type: none"> To have no leakage of gear oil from packings, oil seals or oil plugs. 	Replace the Packing and the Oil Seal.
Oil amount and stain	<ul style="list-style-type: none"> Check the oil level from the oil check hole. (The position of the oil check hole depends on the model. See P37.)  <ul style="list-style-type: none"> Check the VFD for the operating hours 	<p>Gear oil is filled sufficiently (The distance between the hole and the oil level is between 107 to 111mm for the body size D, and 101 to 105 mm for the body size C.)</p>  <ul style="list-style-type: none"> Gear oil has viscosity but not stained. Refer to "Guidelines and Precautions on Gear Oil Change Cycle" for the replacement of oil. (P86) 	Replace the Oil.

■ Electromagnetic Brake

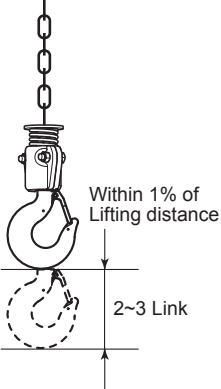
Item	Check method	Criteria	When failed
Brake	<ul style="list-style-type: none"> Lift and lower the electric chain hoist for 20 to 30 cm with a capacity and then stop it. 	<ul style="list-style-type: none"> When stopping the operation, the Brake must be applied immediately and the motor must stop. Elevating : Stop distance must be 1 % or less of the lifting distance. 	Disassemble the Brake to check whether the brake is assembled correctly without abnormal part.

Periodic Inspection (continued)

■ Driving Mechanism

Item	Check method	Criteria	When failed
Bearing	<ul style="list-style-type: none"> • Check for any strange noises. • Check the operating hours with the CH Meter. (Refer to P88.) 	<ul style="list-style-type: none"> • Sounds no strange noise during lifting/ lowering operation with no load. • The operating hours must not exceed the guidelines for replacement. (Refer to Guidelines on Bearing Replacement (P87).) 	Replace the Bearing.
Load Gear, Gear 2, Gear 3, Motor Shaft	<ul style="list-style-type: none"> • Check for any strange noises. • Check the operating hours using the CH Meter. (Refer to P88.) 	<ul style="list-style-type: none"> • To have no apparent abrasion • To have no damage • Operating hours not to exceed the guidelines for replacement (Refer to "Guidelines on Gear Parts Replacement" (P87).) 	<ul style="list-style-type: none"> • Replace the Gear. • Replace the Motor Shaft. • Replace the oil at the same time.
Friction Clutch	<ul style="list-style-type: none"> • Check for any strange noises. • Check the operating hours using the CH Meter. (Refer to P88.) 	<ul style="list-style-type: none"> • Sounds no strange noise during lifting/ lowering operation with no load. <div data-bbox="708 913 1185 1167" style="border: 1px solid black; padding: 5px;"> <p style="text-align: center;">⚠ DANGER</p> <div style="display: flex; align-items: center;">  <ul style="list-style-type: none"> • Do not adjust or disassemble the Friction Clutch. </div> <p>Adjusting and disassembling the Friction Clutch may result in death or serious injury.</p> </div> <ul style="list-style-type: none"> • Operating hours not to exceed the guidelines for replacement (Refer to "Guidelines on Gear Parts Replacement" (P87).) 	Replace the Friction Clutch.

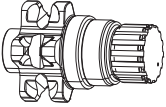
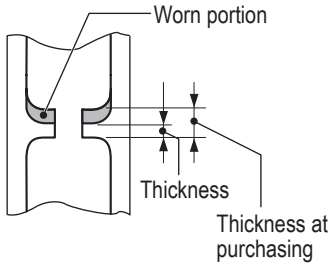
Item	Check method	Criteria	When failed																				
<p>Abrasion and flaw of the Load Sheave</p> 	<ul style="list-style-type: none"> • Check for any popping sounds. • Check the operating hours using the CH Meter. 	<ul style="list-style-type: none"> • To have no apparent abrasion, deformation and damage • To have neither abrasion of the sheave pocket nor the run-on flaw on the crest. <div style="border: 1px solid black; padding: 5px; margin: 10px 0;"> <p style="text-align: center;">NOTE</p> <p>If the abrasion is observed on the Load Sheave, the Load Chain may be worn also. Refer to the item of Load Chain Abrasion and check the abrasion.</p> </div> <ul style="list-style-type: none"> • Service limit of the Load Sheave (Do not fall under the limit) <table border="1" data-bbox="668 745 1147 1003"> <thead> <tr> <th rowspan="2">Model</th> <th rowspan="2">Capacity</th> <th colspan="2">Thickness(mm)</th> </tr> <tr> <th>Standard</th> <th>Limit</th> </tr> </thead> <tbody> <tr> <td>EQ001IS</td> <td>125kg</td> <td rowspan="4" style="text-align: center;">3.4</td> <td rowspan="4" style="text-align: center;">2.3</td> </tr> <tr> <td>EQ003IS</td> <td>250kg</td> </tr> <tr> <td>EQ004IS</td> <td>490kg</td> </tr> <tr> <td>EQ005IS</td> <td>500kg</td> </tr> <tr> <td>EQ010IS</td> <td>1t</td> <td style="text-align: center;">5</td> <td style="text-align: center;">3.3</td> </tr> </tbody> </table> <ul style="list-style-type: none"> • Check the thickness using a slied gauge. 	Model	Capacity	Thickness(mm)		Standard	Limit	EQ001IS	125kg	3.4	2.3	EQ003IS	250kg	EQ004IS	490kg	EQ005IS	500kg	EQ010IS	1t	5	3.3	<p>Replace the Load Sheave.</p>
Model	Capacity	Thickness(mm)																					
		Standard	Limit																				
EQ001IS	125kg	3.4	2.3																				
EQ003IS	250kg																						
EQ004IS	490kg																						
EQ005IS	500kg																						
EQ010IS	1t	5	3.3																				

Periodic Inspection (continued)

■ Electrical Equipment

Item	Check method	Criteria	When failed
Electrical Parts	<ul style="list-style-type: none"> Remove the Controller Cover and check the electrical parts visually. Check the number of start with the CH Meter. (Refer to P88.) 	<ul style="list-style-type: none"> To have no damaged or burnt part. To have no loosened bolt. Electrical parts must be mounted securely. 	Replace the damaged or burnt electrical part. Mount the electrical part securely.
Wiring		<ul style="list-style-type: none"> Wiring must be fixed to the Electrical Parts securely. Connectors must be inserted securely. To have no wire breakage and burning 	Connect wirings securely. Replace the wiring with new wiring, referring to Chapter 3 Guidance on Troubleshooting. (P92 to 93)
Contamination and attachment of foreign matter		<ul style="list-style-type: none"> To have not waterdrop or foreign matter. 	Remove the foreign matter.
VFD	<ul style="list-style-type: none"> Check the parts with service life (see VFD Manual.) * Contact KITO for the manual 	<ul style="list-style-type: none"> Electrolytic capacitor: 3000 hours (depending on the use) 	Replace the VFD.

■ Electric Characteristics Measurement

Item	Check method	Criteria	When failed
Source Voltage	<ul style="list-style-type: none"> Measure the voltage with a circuit tester. 	<ul style="list-style-type: none"> The source voltage of the rated voltage $\pm 10\%$ at the receiving terminal must be supplied when operating with the capacity. <div style="border: 1px solid black; padding: 5px; margin-top: 10px;"> <p style="text-align: center;">⚠ DANGER</p> <div style="display: flex; align-items: center;"> <p style="font-size: 0.8em;"> • Be careful of electric shock when measuring the voltage. Electric shock may result in death or serious injury. </p> </div> </div>	Supply proper voltage.
Insulation Resistance	<ul style="list-style-type: none"> Measure the insulation resistance with megger. (Resistance between energized and non-energized parts ... Each phase of R(L1), S(L2) and T(L3) and the earth wire) 	<ul style="list-style-type: none"> Insulation resistance must be 5 MΩ or higher. <div style="border: 1px solid black; padding: 5px; margin-top: 10px;"> <p style="text-align: center;">⚠ DANGER</p> <div style="display: flex; align-items: center;"> <p style="font-size: 0.8em;"> • Turn off the power when measuring the insulation resistance. Measuring the insulation resistance without turning off the power may result in death or serious injury. </p> </div> </div>	Replace the Body size.

Item	Check method	Criteria	When failed
Grounding Resistance	<ul style="list-style-type: none"> Measure the grounding resistance with earth-resistance meter. 	<ul style="list-style-type: none"> Grounding resistance 100Ω or less <div style="border: 1px solid black; padding: 5px;"> <p style="text-align: center;">⚠ DANGER</p> <div style="display: flex; align-items: center;"> <ul style="list-style-type: none"> Turn off the power when measuring the grounding resistance. </div> <p>Mandatory Measuring the grounding resistance without turning off the power may result in death or serious injury due to electric shock.</p> </div>	Make a grounding correctly.

Function and Performance

⚠ DANGER

- After completion of the inspection of each part, perform the operational check for correct operation.

Neglecting to perform the operational check may result in death or serious injury.

- Perform the following inspections with capacity.

Item	Check method	Criteria	When failed
Operational Check	<ul style="list-style-type: none"> Perform the daily inspection items with capacity. (Refer to Daily inspection Items. (P19)) 	<div style="border: 1px solid black; padding: 5px;"> <p style="text-align: center;">⚠ DANGER</p> <div style="display: flex; align-items: center;"> <ul style="list-style-type: none"> Be sure to perform the capacity test after completion of the no-load test. </div> <p>Mandatory Performing the capacity test without prior no-load test may result in death or serious injury.</p> </div> <ul style="list-style-type: none"> Refer to "Daily inspection Items". (P19) 	Disassemble the electric chain hoist to check whether it is assembled correctly and has no abnormal part.
Brake	<ul style="list-style-type: none"> Operate the electric chain hoist with a capacity and then stop it. 	<ul style="list-style-type: none"> When stopping the operation, the Brake must be applied immediately and the motor must stop. <p>Up/Down: Stop distance must be 1 % or less of the traveling distance for one minute.</p>	Disassemble the Brake to check whether it is assembled correctly and has no abnormal part.

(to be continued)

Periodic Inspection (continued)

Motorized Trolley (MR2Q) Periodic Inspection

Brake

Item	Check method	Criteria	When failed														
Appearance	<ul style="list-style-type: none"> Disassemble the Brake and check it visually. 	<ul style="list-style-type: none"> To have no deformation, flaw and damage on the Brake Drum and the Motor Cover. 	Replace the Part.														
		<ul style="list-style-type: none"> To have no deformation and damage on the Brake Spring. 	Replace the Brake Spring.														
Abrasion of Brake Pad	<ul style="list-style-type: none"> Disassemble the Brake and measure the abrasion. 	Trolley Brake Service Limit (Do not fall under the limit.) <table border="1" style="margin-top: 10px;"> <thead> <tr> <th rowspan="2">Capacity</th> <th rowspan="2">Speed</th> <th colspan="2">Size B(mm)</th> </tr> <tr> <th>Standard</th> <th>Limit</th> </tr> </thead> <tbody> <tr> <td>125kg</td> <td rowspan="5">Dual</td> <td rowspan="5">32.5</td> <td rowspan="5">31.0</td> </tr> <tr> <td>250kg</td> </tr> <tr> <td>490kg</td> </tr> <tr> <td>500kg</td> </tr> <tr> <td>1t</td> </tr> </tbody> </table>	Capacity	Speed	Size B(mm)		Standard	Limit	125kg	Dual	32.5	31.0	250kg	490kg	500kg	1t	Replace the Motor Cover.
Capacity	Speed	Size B(mm)															
		Standard	Limit														
125kg	Dual	32.5	31.0														
250kg																	
490kg																	
500kg																	
1t																	

Body size Components

Item	Check method	Criteria	When failed																				
Wheel	<ul style="list-style-type: none"> Check visually. Measure dimensions D and d with vernier caliper. <p>Wheel for I · H beam (125kg to 1t)</p> <p>Measure the outer diameter with vernier caliper.</p>	<ul style="list-style-type: none"> To have no considerable deformation and damage Abrasion Limit of Wheel (Do not fall under the limit.) <table border="1" style="margin-top: 10px;"> <thead> <tr> <th rowspan="2">Capacity</th> <th rowspan="2">Beam type</th> <th colspan="2">D (mm)</th> <th colspan="2">d (mm)</th> </tr> <tr> <th>Standard</th> <th>Limit</th> <th>Standard</th> <th>Limit</th> </tr> </thead> <tbody> <tr> <td>125kg</td> <td rowspan="5">I · H</td> <td rowspan="5">95</td> <td rowspan="5">91</td> <td rowspan="5">91.5</td> <td rowspan="5">87.5</td> </tr> <tr> <td>250kg</td> </tr> <tr> <td>490kg</td> </tr> <tr> <td>500kg</td> </tr> <tr> <td>1t</td> </tr> </tbody> </table>	Capacity	Beam type	D (mm)		d (mm)		Standard	Limit	Standard	Limit	125kg	I · H	95	91	91.5	87.5	250kg	490kg	500kg	1t	Replace the Wheel.
Capacity	Beam type	D (mm)			d (mm)																		
		Standard	Limit	Standard	Limit																		
125kg	I · H	95	91	91.5	87.5																		
250kg																							
490kg																							
500kg																							
1t																							
Side Roller	<ul style="list-style-type: none"> Check visually. Measure outer diameter of the worn part with vernier caliper. 	<ul style="list-style-type: none"> To have no considerable deformation and damage Abrasion Limit of Side Roller (Do not fall under the limit.) <table border="1" style="margin-top: 10px;"> <thead> <tr> <th rowspan="2">Capacity</th> <th colspan="2">Size B(mm)</th> </tr> <tr> <th>Standard</th> <th>Limit</th> </tr> </thead> <tbody> <tr> <td>125kg</td> <td rowspan="5">38</td> <td rowspan="5">37</td> </tr> <tr> <td>250kg</td> </tr> <tr> <td>490kg</td> </tr> <tr> <td>500kg</td> </tr> <tr> <td>1t</td> </tr> </tbody> </table>	Capacity	Size B(mm)		Standard	Limit	125kg	38	37	250kg	490kg	500kg	1t	Replace the Side Roller.								
Capacity	Size B(mm)																						
	Standard	Limit																					
125kg	38	37																					
250kg																							
490kg																							
500kg																							
1t																							

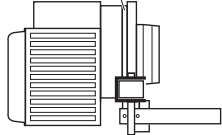
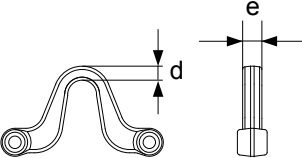
Item	Check method	Criteria	When failed																																									
Lifting Shaft	<ul style="list-style-type: none"> Check visually. Measure the shaft diameter with vernier caliper. <p style="text-align: center;">Shaft diameter</p> 	<ul style="list-style-type: none"> To have no considerable deformation and abrasion The shaft with obvious deformation reaches at the service limit. Abrasion limit of the shaft is 5 % of its diameter 	Replace the Lifting shaft.																																									
Gear Frame Packing	<ul style="list-style-type: none"> Check visually. <p style="text-align: center;">Gear Frame Packing</p> 	<ul style="list-style-type: none"> To have no damage and breakage. 	Replace the Gear Frame Packing.																																									
Gears and Motor Shaft	<ul style="list-style-type: none"> Check for any strange noises. 	<ul style="list-style-type: none"> Sounds no strange noise during lifting/ lowering operation with no load. 	Replace the Part.																																									
Suspension Eye	<ul style="list-style-type: none"> Check visually and measure with vernier caliper. 	<table border="1" style="margin-left: auto; margin-right: auto;"> <thead> <tr> <th colspan="2">Measured value (mm)</th> <th colspan="2">Limit value</th> </tr> </thead> <tbody> <tr> <td rowspan="2">Suspension Eye</td> <td>Dimension d</td> <td colspan="2" rowspan="2">Abrasion not to exceed 5%</td> </tr> <tr> <td>Dimension e</td> </tr> </tbody> </table> <p> <ul style="list-style-type: none"> Following tables shows the nominal standard values. Please be aware that these values include tolerance because of forging. Guidelines on the Suspension Eye (refer to P87) or its criteria </p> <table border="1" style="margin-left: auto; margin-right: auto;"> <thead> <tr> <th rowspan="3">Code</th> <th rowspan="3">Capacity</th> <th colspan="4">Suspension Eye</th> </tr> <tr> <th colspan="2">Dimension d (mm)</th> <th colspan="2">Dimension e (mm)</th> </tr> <tr> <th>Standard</th> <th>Limit value</th> <th>Standard</th> <th>Limit value</th> </tr> </thead> <tbody> <tr> <td>EQ001IS</td> <td>125kg</td> <td rowspan="3">8.0</td> <td rowspan="3">7.6</td> <td rowspan="3">16.0</td> <td rowspan="3">15.2</td> </tr> <tr> <td>EQ003IS</td> <td>250kg</td> </tr> <tr> <td>EQ004IS</td> <td>490kg</td> </tr> <tr> <td>EQ005IS</td> <td>500kg</td> <td rowspan="2">12.3</td> <td rowspan="2">11.7</td> <td rowspan="2">22.0</td> <td rowspan="2">20.9</td> </tr> <tr> <td>EQ010IS</td> <td>1t</td> </tr> </tbody> </table>	Measured value (mm)		Limit value		Suspension Eye	Dimension d	Abrasion not to exceed 5%		Dimension e	Code	Capacity	Suspension Eye				Dimension d (mm)		Dimension e (mm)		Standard	Limit value	Standard	Limit value	EQ001IS	125kg	8.0	7.6	16.0	15.2	EQ003IS	250kg	EQ004IS	490kg	EQ005IS	500kg	12.3	11.7	22.0	20.9	EQ010IS	1t	<ul style="list-style-type: none"> Replace the Suspension Eye.
Measured value (mm)		Limit value																																										
Suspension Eye	Dimension d	Abrasion not to exceed 5%																																										
	Dimension e																																											
Code	Capacity	Suspension Eye																																										
		Dimension d (mm)		Dimension e (mm)																																								
		Standard	Limit value	Standard	Limit value																																							
EQ001IS	125kg	8.0	7.6	16.0	15.2																																							
EQ003IS	250kg																																											
EQ004IS	490kg																																											
EQ005IS	500kg	12.3	11.7	22.0	20.9																																							
EQ010IS	1t																																											

Periodic Inspection (continued)

Travel Rail

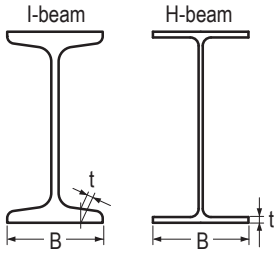
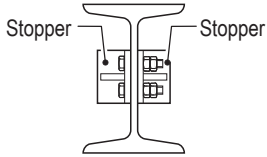
Item	Check method	Criteria	When failed
Rail Surface	<ul style="list-style-type: none"> Check visually. 	<ul style="list-style-type: none"> To have no attachment of paint, oil and foreign matter. To have no dust and powder due to abrasion 	Clean the Travel Rail.
Deformation and Abrasion	<ul style="list-style-type: none"> Check the deformation and abrasion visually and measure them with vernier caliper. 	<ul style="list-style-type: none"> To have no deformation of beam flange such as twist and shear drop To have no exceeding abrasion of rail surface Service limit of B: up to 95 % of the dimension at purchasing Service limit of t: up to 90 % of the dimension at purchasing 	Replace or repair the Travel Rail.
Rail Mounting Bolt	<ul style="list-style-type: none"> Check visually. 	<ul style="list-style-type: none"> To have no loosened bolt or fall-off 	Tighten the bolts securely.
Stopper	<ul style="list-style-type: none"> Check visually. 	<ul style="list-style-type: none"> The stoppers must be mounted at the both ends of the Travel Rail securely. 	Tighten the Stoppers.

Relay Cable

Item	Check method	Criteria	When failed
Appearance	<ul style="list-style-type: none"> Check the cable surface visually. 	<ul style="list-style-type: none"> The Relay Cable has no deformation or damage. To be mounted securely. 	Replace the Relay Cable.

Electrical Equipment and Electric Characteristics

Refer to Electric Chain Hoist (EQ) Periodic Inspection (P78 to 79).

Function and Performance

⚠ DANGER



Mandatory

- After completion of the inspection of each part, perform the operational check for correct operation.
- Neglecting to perform the operational check may result in death or serious injury.

- Perform the following inspections with capacity.

Item	Check method	Criteria	When failed
Operational Check	<ul style="list-style-type: none"> • Perform the daily inspection items with capacity. (Refer to “Daily inspection Items”. (P24)) 	<div style="border: 1px solid black; padding: 5px; margin-bottom: 10px;"> <p>⚠ DANGER</p>  <p>Mandatory</p> <ul style="list-style-type: none"> • Be sure to perform the capacity test after completion of the no-load test. <p>Performing the capacity test without prior no-load test may result in death or serious injury.</p> </div> <ul style="list-style-type: none"> • Refer to “Daily inspection Items”. (P24) 	Disassemble the electric chain hoist to check whether it is assembled correctly and has no abnormal part.
Brake	<ul style="list-style-type: none"> • Operate the electric chain hoist with a capacity and then stop it. 	<ul style="list-style-type: none"> • When stopping the operation, the Brake must be applied immediately and the motor must stop. <p>Traveling : Stop distance must be 10 % or less of the traveling distance for one minute.</p> <p>(Without swinging of the load. Except the case when the load is swinging.)</p>	Disassemble the Brake to check whether the brake is assembled correctly without abnormal part.
Abnormal Noise	<ul style="list-style-type: none"> • Operate the electric chain hoist with a capacity and then stop it. 	<ul style="list-style-type: none"> • To have no irrotating noise • To sound no howling of motor and scraping sound of the Brake. 	Disassemble the electric chain hoist to check whether it is assembled correctly and has no abnormal part.

(to be continued)

Periodic Inspection (continued)

Manual Trolley (TSP) Periodic Inspection

Body size Components

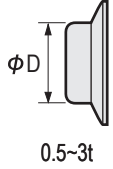
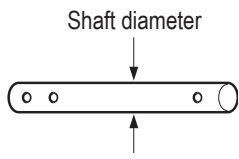
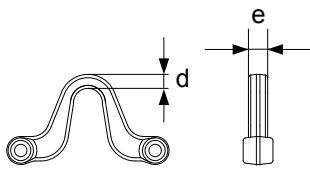
Item	Check method	Criteria	When failed																																									
Wheel	<ul style="list-style-type: none"> Check visually. Measure dimension D with vernier caliper.  <ul style="list-style-type: none"> Measure the outer diameter with vernier caliper. 	<ul style="list-style-type: none"> To have no considerable deformation and damage Abrasion Limit of Wheel (Do not fall under the limit.) <table border="1" data-bbox="702 548 1436 817"> <thead> <tr> <th rowspan="2">Capacity</th> <th rowspan="2">Beam</th> <th colspan="2">D (mm)</th> <th colspan="2">Flange thickness (mm)</th> </tr> <tr> <th>Standard</th> <th>Limit</th> <th>Standard</th> <th>Limit</th> </tr> </thead> <tbody> <tr> <td rowspan="2">125kg, 250kg, 490kg, 500kg</td> <td>H-beam</td> <td rowspan="2">60</td> <td>58.5</td> <td rowspan="4">To have no considerable damage or crack on the contact surface.</td> <td rowspan="4">To have no considerable damage or crack at the flange.</td> </tr> <tr> <td>I-beam</td> <td></td> </tr> <tr> <td rowspan="2">1t</td> <td>H-beam</td> <td rowspan="2">71</td> <td>69.5</td> </tr> <tr> <td>I-beam</td> <td></td> </tr> </tbody> </table>	Capacity	Beam	D (mm)		Flange thickness (mm)		Standard	Limit	Standard	Limit	125kg, 250kg, 490kg, 500kg	H-beam	60	58.5	To have no considerable damage or crack on the contact surface.	To have no considerable damage or crack at the flange.	I-beam		1t	H-beam	71	69.5	I-beam		Replace the Wheel.																	
Capacity	Beam	D (mm)			Flange thickness (mm)																																							
		Standard	Limit	Standard	Limit																																							
125kg, 250kg, 490kg, 500kg	H-beam	60	58.5	To have no considerable damage or crack on the contact surface.	To have no considerable damage or crack at the flange.																																							
	I-beam																																											
1t	H-beam	71	69.5																																									
	I-beam																																											
Lifting Shaft	<ul style="list-style-type: none"> Check visually. Measure the shaft diameter with vernier caliper. 	<ul style="list-style-type: none"> To have no considerable deformation and abrasion The shaft with obvious deformation reaches at the service limit. Abrasion limit of the shaft and the hole is 5% of its diameter respectively. 	Replace the Lifting Shaft.																																									
Suspension Eye	<ul style="list-style-type: none"> Check visually and measure with vernier caliper. 	<table border="1" data-bbox="718 1220 1300 1321"> <thead> <tr> <th colspan="2">Measured value (mm)</th> <th colspan="2">Limit value</th> </tr> </thead> <tbody> <tr> <td rowspan="2">Suspension Eye</td> <td>Dimension d</td> <td colspan="2" rowspan="2">Abrasion not to exceed 5%</td> </tr> <tr> <td>Dimension e</td> </tr> </tbody> </table> <ul style="list-style-type: none"> Following tables shows the nominal standard values. Please be aware that these values include tolerance because of forging. Guidelines on the Hook and Suspension Eye (refer to P87) or its criteria <table border="1" data-bbox="718 1500 1300 1713"> <thead> <tr> <th rowspan="3">Code</th> <th rowspan="3">Capacity</th> <th colspan="4">Suspension Eye</th> </tr> <tr> <th colspan="2">Dimension d (mm)</th> <th colspan="2">Dimension e (mm)</th> </tr> <tr> <th>Standard</th> <th>Limit value</th> <th>Standard</th> <th>Limit value</th> </tr> </thead> <tbody> <tr> <td>EQ001IS</td> <td>125kg</td> <td rowspan="4">8.0</td> <td rowspan="4">7.6</td> <td rowspan="4">16.0</td> <td rowspan="4">15.2</td> </tr> <tr> <td>EQ003IS</td> <td>250kg</td> </tr> <tr> <td>EQ004IS</td> <td>490kg</td> </tr> <tr> <td>EQ005IS</td> <td>500kg</td> </tr> <tr> <td>EQ010IS</td> <td>1t</td> <td>12.3</td> <td>11.7</td> <td>22.0</td> <td>20.9</td> </tr> </tbody> </table>	Measured value (mm)		Limit value		Suspension Eye	Dimension d	Abrasion not to exceed 5%		Dimension e	Code	Capacity	Suspension Eye				Dimension d (mm)		Dimension e (mm)		Standard	Limit value	Standard	Limit value	EQ001IS	125kg	8.0	7.6	16.0	15.2	EQ003IS	250kg	EQ004IS	490kg	EQ005IS	500kg	EQ010IS	1t	12.3	11.7	22.0	20.9	<ul style="list-style-type: none"> Replace the Suspension Eye.
Measured value (mm)		Limit value																																										
Suspension Eye	Dimension d	Abrasion not to exceed 5%																																										
	Dimension e																																											
Code	Capacity	Suspension Eye																																										
		Dimension d (mm)		Dimension e (mm)																																								
		Standard	Limit value	Standard	Limit value																																							
EQ001IS	125kg	8.0	7.6	16.0	15.2																																							
EQ003IS	250kg																																											
EQ004IS	490kg																																											
EQ005IS	500kg																																											
EQ010IS	1t	12.3	11.7	22.0	20.9																																							

Travel Rail

Item	Check method	Criteria	When failed
Rail Surface	<ul style="list-style-type: none"> Check visually. 	<ul style="list-style-type: none"> To have no attachment of paint, oil and foreign matter. To have no dust and powder due to abrasion 	Clean the Travel Rail.

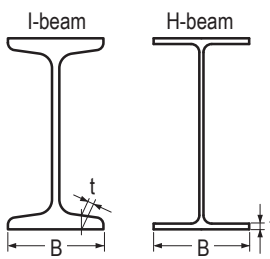
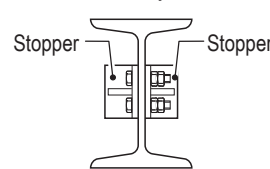
Item	Check method	Criteria	When failed
Deformation and Abrasion	<ul style="list-style-type: none"> Check the deformation and abrasion visually and measure them with vernier caliper. 	<ul style="list-style-type: none"> To have no deformation of beam flange such as twist and shear drop To have no exceeding abrasion of rail surface Service limit of B: up to 95 % of the dimension at purchasing Service limit of t up to 90 % of the dimension at purchasing 	Replace or repair the Travel Rail.
Rail Mounting Bolt	<ul style="list-style-type: none"> Check visually. 	<ul style="list-style-type: none"> To have no loosened bolt or fall-off 	Tighten the bolts securely.
Stopper	<ul style="list-style-type: none"> Check visually. 	<ul style="list-style-type: none"> The stoppers must be mounted at the both ends of the Travel Rail securely. 	Tighten the Stoppers.

Function and Performance

⚠ DANGER



Mandatory

- After completion of the inspection of each part, perform the operational check for correct operation. Neglecting to perform the operational check may result in death or serious injury.

- Perform the following inspections with capacity.

Item	Check method	Criteria	When failed
Operational Check	<ul style="list-style-type: none"> Perform the daily inspection items with capacity. (Refer to Daily inspection Items. (P25)) 	<div style="border: 1px solid black; padding: 5px;"> <p>⚠ DANGER</p>  <p>Mandatory</p> <ul style="list-style-type: none"> Be sure to perform the capacity test after completion of the no-load test. <p>Performing the capacity test without prior no-load test may result in death or serious injury.</p> </div> <ul style="list-style-type: none"> Refer to "Daily Inspection Items". (P25) 	Disassemble the electric chain hoist to check whether it is assembled correctly and has no abnormal part.
Abnormal Noise	<ul style="list-style-type: none"> To make the electric chain hoist travel with a capacity 	<ul style="list-style-type: none"> To have no irregular rotating sound 	Disassemble the electric chain hoist to check whether it is assembled correctly and has no abnormal part.

Guidelines for Parts Replacement based on Indication of CH Meter

When performing the inspection, check the number of start and operating hours and utilize them for operation status control and maintenance control.

Check the number of start and operating hours with the indicator of the VFD by the maintenance engineer in accordance with the separate "VFD Manual" and P84 of this manual.

■ Guidelines and Precautions on Gear Oil Change Cycle

Change the gear oil in accordance with the rate of loading and the operating hours.

- Change the oil at every five years even if the operating hours do not reach at the following hours.

Rate of loading		Operating hour for gear oil change		
		Every 120 hrs	Every 240 hrs	Every 360 hrs
Light	A case where the capacity is rarely applied. Usually the hoist is used with a light load.			○
Medium	A case where the capacity is applied considerably frequently. Usually the hoist is used with a medium load.		○	
Heavy	A case where the capacity is applied considerably frequently. Usually the hoist is used with a heavy load.	○		
Ultra heavy	A case where the capacity is applied constantly.	○		

⚠ CAUTION



Mandatory

- Use of wrong gear oil may result in the drop of the lifted load. Be sure to use the designated gear oil.

Gear oil kind and amount for main unit

Code	Amount gear oil(ml)	Oil
EQ001IS, EQ003IS, EQ005IS	510	KITO genuine product
EQ010IS	840	KITO genuine product

■ Guidelines for Checking Brake

- When the number of start reaches 1 million times, check the dimension of B and execute the counteraction in the table below depending on the condition.
- When the number of start reaches 2 million times, replace the brake drum, motor cover, brake spring and pull rotor spring no matter what condition the B dimension is.

Condition of B dimension	Action
When it reaches the critical limit	Replace the brake drum, motor cover, brake spring and pull rotor spring.
When it reaches near end of the critical limit rather than the intermediate point between standard and critical limit.	From that time on, check the B condition every hundred thousand times of use till it reaches to the critical limit.
When it reaches near end of the standard rather than the intermediate point between standard and critical limit.	Check the B condition every two hundred thousand times of use.

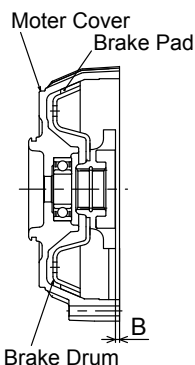

<125kg, 250kg, 490kg, 500kg>

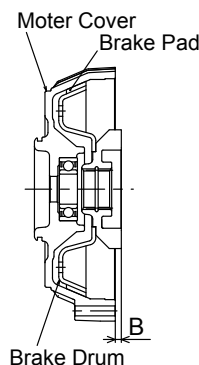

<1t>

Abrasion of Brake pad when using Brake (It should not below the limit.)

Code	Capacity	Speed	B dimension (mm)		Criteria
			Standard	Limit	
EQ001IS EQ003IS EQ004IS EQ005IS	125kg, 250kg, 490kg, 500kg	Dual	3	3.5	Not to exceed
EQ010IS	1t		4	3.5	Not to fall below

■ Guidelines on Gear Parts Replacement (Load Gear, Friction clutch with Gear 2, Gear 3)

Operating hours to replace parts Body size grade	Every 800 hours	Every 1600 hours	Every 3200 hours
M5, 2m	–	Parts replacement	–
M6, 3m	–	–	Parts replacement

■ Guidelines on Motor Shaft (with Rotor) Replacement

Operating hours to replace parts Body size grade	Every 400 hours	Every 800 hours	Every 1600 hours	Every 3200 hours
M5, 2m	–	Apply grease on spline	Parts replacement	–
M6, 3m	–	Apply grease on spline	–	Parts replacement

* Grease needs to be applied on spline part every 800, 1600 and 2400 hours.

■ Guidelines on Bearing Replacement

Operating hours to replace parts Body size grade	Every 800 hours	Every 1600 hours	Every 3200 hours
M5, 2m	–	Parts replacement	–
M6, 3m	–	–	Parts replacement

■ Guidelines on Hook, Yoke and Suspension Eye Replacement

Replace the Hook, Yoke and Suspension Eye in accordance with the rate of loading and the number of start in the following table.

Rate of loading		Number of start to replace parts	Every million times	Every 1.5 million times	Every 2 million times
Light	A case where the capacity is rarely applied. Usually the hoist is used with a light load.				○
Medium	A case where the capacity is applied considerably frequently. Usually the hoist is used with a medium load.			○	
Heavy	A case where the capacity is applied considerably frequently. Usually the hoist is used with a heavy load.		○		
Ultra heavy	A case where the capacity is applied constantly.		○		

Check of Operating Hours and Number of Start (CH Meter)

⚠ CAUTION

This section is extracted from the VFD Manual. For details on operation, etc, refer to the separate VFD Manual.

■ Start Times/Operating Hour Display Device

The numbers of start of the upper level and lower level are separately displayed on the LED operator. Calculate the numbers of start from the display.

■ The display contents of the number of start and operating hours

The numbers of start of the upper level and lower level are separately displayed as shown below.

No.	Name	Content
U7-01	Number of start (upper)	The sum of the lifting/lowering of 1,000 times is displayed as 1 unit. The maximum of 10,000 units is displayed. This indicates 10,000 × 1,000=10,000,000 times.
U7-02	Number of start (lower)	The sum of the lifting/lowering is displayed as 1 unit. The maximum of 999 units is displayed. Once it counts 1,000 times, the value of U7-01 (upper) is counted as +1 while U7-02 (lower) goes back to 0.
U7-03	Operating hours	The operating hours are displayed by the hour. The maximum of 65,535 hours is displayed.

Note: The maximum value which is displayable does not indicate the expiry of service life.

■ Displaying of the numbers of start and operating hours

To display the numbers of start and operating hours on the LED operator, follow the procedure below. The following is the example of displaying the operating hours.

Ex.) Refer to the below for the display as taking an example of U7-03 (Operating time).

Operating Procedure

1. Turn the power on.
2. Press till the monitor screen is displayed.
3. Press to display the Parameter setting screen, and press .
4. Press or to display U7-01.
5. Press , , or and set to U7-03 (operating hours)
6. Press to display the current value.
7. To finish monitoring and resume operation, hold down till the screen returns to the initial screen.

LED Display



Initial screen



Parameter setting screen



75 hours



■ Calculating the number of start

Calculate the numbers of start of the upper level and lower level from the display.

The following is the calculation example.

Example: When "81" is displayed on U7-01 and "567" is displayed on U7-02

The number of start of lowering = $81 \times 1,000 + 567$ is 81,567 times.

■ Converting the operating hours

When "122" is displayed on U7-03, the operating hours are 122.

Chapter 3

Troubleshooting

This chapter describes the main failure cause and inspection items based on the fault conditions. The repair work (and maintenance work as well) of the electric chain hoist is accompanied with disassembling/assembling work. Refer to the separate “Disassembling/Assembling Manual” for the correct work.

■ Guidance on Troubleshooting.....	92
■ Safety Precautions	94
■ Troubleshooting.....	95
• Power	95
• Circuit breaker	95
• Power Cable	96
• Motor.....	97
• Brake.....	98
• Internal wiring	98
• Upper/Lower Limit Switch.....	99
• Push Button Switch.....	100
• VFD.....	101
• HBB Board.....	101
• Braking Resistor	101
• Electric shock	102
• Friction Clutch	102
• Hook.....	103
• Load Chain	105
• Load Sheave.....	107
• Chain Guide.....	107
• Gears.....	107
• Bearing	108
• Traveling motion of the Trolley.....	108

Guidance on Troubleshooting

■ Guidance on Troubleshooting

Following table is the summary of the main failure causes based on the failure conditions and their inspection items. Refer to the page of each item for the check method, treatment and the details of countermeasure.

Conditions		Main fault contents	Check item	Reference page
Unable to restart the VFD by resetting with emergency stop (the case when the VFD cannot be reset even after cool down)		Those related to VFD	Check the error code of VFD referring to "VFD Manual".	"VFD Manual" (annex)
Electric chain hoist does not operate without load	Sounds no brake operating sound	Improper source voltage	Power	95
		Breakage and burning of control circuit	Circuit breaker	95
			Power Cable	96
		Faulty electrical part	Internal wiring	98
			HBB Board	101
		VFD	101	
		Upper/Lower Limit Switch	99	
		Push Button Switch	100	
	Breakage and burning of power circuit	Motor	97	
		Internal wiring	98	
VFD trip due to motor overheat (electronic thermal relay)	VFD	101		
	VFD overheat	VFD	101	
Sounds brake operating sound	Breakage of driving part	Gears	107	
	Sticking of Bearing	Bearing	108	
Electric chain hoist operates without load	Does not operate with a load (Motor sounds howling)	Overload (Clutch activated)	Friction Clutch	102
	Operates slowly with a load	Voltage drop	Power Cable	96
	Electric chain hoist operates in low speed mode, but does not operate in high speed mode or operates slowly.	Low source voltage	Power	95
		Voltage drop	Power Cable	96
Does not operate in lowering or in low speed mode.	Faulty Braking Resistor	Braking Resistor	101	
Operates differently from the indication of the Push Button Switch.	Operates differently from the indication of the Push Button Switch (operates in the opposite direction)	Negative phase connection of motor lead wires	Motor	97
		Wrong connection	Internal wiring	98
	Push Button Switch		100	
	Does not operate when operating any one of the Push Button Switch	Breakage of control circuit	Internal wiring	98
			Push Button Switch	100
		Faulty electrical part	VFD	101
HBB Board			101	
Upper/Lower Limit Switch	99			

Conditions		Main fault contents	Check item	Reference page
Does not stop normally	Too long (or short) stopping distance	Abrasion of brake lining	Brake	98
	Does not stop at the upper/lower limit.	Negative phase connection of motor lead wires	Power Cable	96
		Wrong connection	Internal wiring	98
			Push Button Switch	100
Abnormal noise	Popping sound	Abrasion of the Load Chain	Load Chain	105
		Abrasion of the Load Sheave	Load Sheave	107
	Sounds strange operating sound	Abrasion or breakage of Gear Deterioration of Bearing	Gears	107
			Bearing	108
	Brake noise	Sounds when applied (scraping noise)	Dragging	Brake
Sounds when released		Abrasion of brake lining	Brake	98
Sounds at curved rail (friction noise)		Mechanical interference of the rail and the wheel	Traveling motion of the Trolley	108 109
Unable to travel	Motorized Trolley/Manual Trolley	Slipping wheel	Traveling motion of the Trolley	108
		Inclined rail		109
		Pulling a load in an inclined direction (floating wheel)		
		Defective gear engagement		
		Locking of brake		
	Motorized Trolley	Electric system failure (refer to the item of electric chain hoist)		
Serpentine motion Sounds strange noise	Motorized Trolley/Manual Trolley	Mechanical interference of the rail and the wheel	Traveling motion of the Trolley	108
		Wrong adjustment of spacer		109
		Uneven abrasion of the wheel		
		Deformation of the wheel		
		Deterioration of Bearing		
		Deformation and abrasion of the rail		
		Deterioration of the Bearing		
		Abrasion of the Brake Pad		
Hook and those related to Hook		Deformation	Hook	103 104
Load Chain and those related to Load Chain		Abrasion, elongation, twist	Load Chain	105
Electric shock when touching the body size and Push Button Switch		Improper grounding, breakage of earth wire	Electric shock	102

Safety Precautions

General Matters on Failure Cause and Countermeasure

DANGER



Prohibited

- **Do not disassemble or repair the electric chain hoist by the personnel other than maintenance engineer.** “Disassembling/Assembling Manual” and “Parts List” are provided separately for the maintenance. Disassembling and repair must be performed by the maintenance engineer in accordance with these materials for maintenance.

Failure to comply with this content may result in death or serious injury.



Mandatory

- **When replacing the part, be sure to use the genuine part for KITO electric chain hoist EQ, EQM and EQSP.** Even if the part is the KITO genuine part, the part for different model may not be used. Use the correct part in accordance with separate “Disassembling/Assembling Manual”.
- **When any abnormality is observed during the repair (maintenance) of the electric chain hoist, survey the cause by the maintenance engineer and carry out the repair.**
- **Be sure to keep the following when repairing the electric chain hoist:**
 - **Be sure to turn off the power.**
 - **Be sure to indicate “CHECKING”.**
 - **Carry out the repair without lifting a load.**
- **Be sure to pay attention to the change of the operating sound of electric chain hoist and trolley.** The change of operating sound is an important factor to judge the failure.

Failure to comply with this content may result in death or serious injury.

General Matters on Handling the Model EQ Electric Chain Hoist

The Model EQ Electric Chain Hoist is controlled by the VFD for important items related to safety such as operation, braking and emergency stop. Be sure to follow the safety precautions below as well as the above safety precautions.

DANGER



Prohibited

- **Do not disassemble the Model EQ Electric Chain Hoist in the same way as the contactor system.**
- **Do not change the VFD parameters.** When parameters need to be changed, ask our distributors nearest to the customer or KITO.
- **Do not carry out the work such as maintenance and inspection within 5 minutes after power off.** Wait for the completion of discharging of the capacitor inside the VFD.
- **Fan Cover becomes very hot during operation. Do not touch it.**
- **Do not touch the Fan Cover within 30 minutes after the operation.**
- **USE KITO genuine VFD.** The VFD requires the special specification for KITO. Be sure to use genuine VFD.
- **Do not change the connection of the VFD.** When the wires were removed for any reason, connect them again correctly checking the wiring diagram inside the controller cover.
- **Do not carry out withstand voltage test of a circuit while the VFD is connected.**
- **Do not turn off the power while operating.**

Failure to comply with these instructions may result in death or serious injury and the damage of VFD.



Mandatory

- **USE KITO genuine VFD.** The VFD requires the special specification for KITO. Be sure to use genuine VFD.

Failure to comply with this content may result in death or serious injury.

Troubleshooting

Power

Symptom	Cause	Remedy	Main factor	Countermeasure
Electric chain hoist does not operate.	Improper source voltage	Measure the voltage of each phase at power receiving terminal. If the source voltage is improper, check the power receiving facility.	Faulty power receiving facility	Check the power receiving facility regularly.
<div style="border: 1px solid black; padding: 5px; margin: 10px auto; width: fit-content;"> <p style="text-align: center;">⚠ DANGER</p> <div style="display: flex; align-items: center;"> <ul style="list-style-type: none"> Be careful about electric shock when checking the power. </div> <p style="font-size: small; margin-top: 5px;">Careless power check may result in death or serious injury due to electric shock.</p> </div>				

Circuit breaker (Distribution panel)

Symptom	Cause	Remedy	Main factor	Countermeasure
Electric chain hoist does not operate.	Breaker was tripped due to short circuit.	Replace or repair the short-circuited part.	Cable breakage, burning of electrical parts	Refer to each item of Power Cable, Motor and Internal Wiring.
	Breaker was tripped due to insufficient breaker capacity.	Check the breaker capacity. Replace it if the capacity is insufficient.	Wrong selection of breaker capacity	Use the breaker with proper capacity. (See P48.)
	Breaker was tripped due to over current.	Check the cause of over current and take the necessary countermeasure. (Refer to each item of Power Cable, Motor, Brake and Internal Wiring.)	Over voltage, low voltage, over load	Refer to each item of Power Cable, Motor, and Internal Wiring.

Troubleshooting (continued)**Power Cable**

Symptom	Cause	Remedy	Main factor	Countermeasure
Electric chain hoist does not operate.	Wire breakage (more than two wires)	Check the conduction, flaw, crimping of terminals and soldering of plug. When any deficiency was observed, repair or replace the cable.	Excessive force applied on the cable	Support the cable with Cable Support Arm securely.
			Non use of shake proof cable	Use shake proof cable to the moving part.
			Twist of wire	Layout the wires without twisting.
			Cable was impeded by other facility.	Fix the cable not to be impeded by other facility.
Wire burning (more than two wires)	Check the cable. Replace it if burnt.	Temperature rise due to insufficient cable capacity	Use the cable with proper capacity. (See P48.)	
			Cables are bundled.	Do not bundle wires.
			Insufficient insertion of plug	Insert the connector plug to the end of the receptacle. Tighten the coupling ring securely.
Loosening of the fixing thread due to impact or vibration	Use the electric chain hoist avoiding the large impact.			
Slow start or unable to start	Insufficient cable capacity	Check the cable size for adequacy. Replace with the proper cable if the cable capacity is insufficient.	Voltage drop due to insufficient cable capacity	Use the cable with proper capacity. (See P48.)
Electric chain hoist operates but unable to lift a load. (single phase status)	Breakage or burning of one wire only	Refer to the breakage and burning of above items.		

Motor

Symptom	Cause	Remedy	Main factor	Countermeasure				
Motor does not operate.	Motor coil burning (two or more phases)	Measure the coil resistance of each phase. Replace the motor when the resistance of all phases are infinity.	Over current due to over voltage or low voltage	Operate the electric chain hoist at the rated voltage.				
			Over current due to over load	Operate the electric chain hoist with a load less than the capacity.				
			Operation exceeding intermittent rating	Check the intermittent rating. Operate the electric chain hoist within these ratings.				
			Excessive inching or plugging operation (consecutive impression of start rush current)	Do not perform excessive operation.				
			Over current due to brake dragging	Refer to the items of Brake.				
	Lead wire breakage (more than two lead wires)	Measure the coil resistance of each phase. Replace the motor when the resistance of all phases are infinity.	Lead wire damaged at assembling	Assemble with care.				
Electric chain hoist operates but unable to lift a load. (single phase status)	Motor coil burning (only one phase)	Measure the coil resistance of each phase. Replace the motor when the resistance of all phases are infinity.	Layer short due to poor insulation of coil (between phases)	Be careful about the intrusion of foreign matter into the motor when assembling.				
					Lead wire breakage (only in one lead wire)	Measure the coil resistance of each phase. Replace the motor when the resistance of all phases are infinity.	Lead wire damaged at assembling	Be careful not to have the lead wire caught when assembling.
							Vibration, impact	Use the electric chain hoist avoiding the impact.
	Lead wire breakage (only in one lead wire)	Measure the coil resistance of each phase. Replace the motor when the resistance of all phases are infinity.	Vibration, impact	Use the electric chain hoist avoiding the impact.				
					Lead wire damaged at assembling	Be careful not to have the lead wire caught when assembling.		
							Vibration, impact	Use the electric chain hoist avoiding the impact.

Troubleshooting (continued)**Brake**

Symptom	Cause	Remedy	Main factor	Countermeasure
Stops after traveling over 4 to 5 links after the operation is stopped. (Guideline: The travel of the Load Chain is within 2 to 3 links.)	Abrasion of brake lining	Check the manner of operation (excessive inching or frequent use). Carry out the inspection and use it correctly.	Excessive inching Frequent use	Check the electric chain hoist regularly. Use it correctly in accordance with the manual.
The load slides down when stopped	Defective function of the Friction	Check the place to use and friction function. Carry out the inspection and use it correctly.	Abrasion from habitual use for a long time Change in mechanical characteristics from leaving it for a long time	Use it correctly in accordance with the manual Pay attention to the place to use and the storage place.

Internal wiring

Symptom	Cause	Remedy	Main factor	Countermeasure
Electric chain hoist does not operate.	Breakage of wire	Check the wire. Repair the wire if broken.	Vibration, impact	Use the electric chain hoist avoiding the impact.
			Lead wire damaged at assembling	Be careful not to have the lead wire caught when assembling.
		Check the terminal. Repair the terminal if it is broken.	Improper crimping	Use the proper crimping tool.
	Wrong wiring	Check the wiring in accordance with the wiring diagram. Correct the wiring if it is wrong.	Wrong wiring at assembling	Correct the wiring in accordance with the wiring diagram.
	Loosened terminal screw (results in heat generation to burn)	Tighten the loosened screws.	Insufficient tightening at assembling	Tighten screws securely.
			Vibration, impact	Use the electric chain hoist avoiding the impact.
Incomplete connection of plug, connector and insertion terminal	Connect plug, connector and insertion terminal correctly if they are not connected securely. Tighten the lock ring of the connector plug securely.	Incomplete connection at assembling	Connect plug, connector and insertion terminal securely.	

Upper/Lower Limit Switch

Symptom	Cause	Remedy	Main factor	Countermeasure
Electric chain hoist does not operate. (Electromagnetic Contactor or VFD does not operate.)	Contact point fusing	Actuate the limit switch manually to check the conduction of the contact points. Replace the limit switch as a whole when no conduction.	Habitual use of the limit switch	Do not use the limit switch habitually.
	Breakage	Check the wiring. Repair or replace the limit switch as a whole if the limit switch has no conduction.	Vibration, impact	Use the electric chain hoist avoiding the impact.
	Defective return action of the moving part	Check the moving part of the limit switch is not stiff. If it is stiff, replace the limit switch as a whole.	Leaving the electric chain hoist for a long time at the upper/lower limit.	Do not leave the electric chain hoist at the upper/lower limit.
Electric chain hoist does not stop at the upper/lower limit.	Contact point welding	Actuate the limit switch manually to check the conduction of the contact points. Replace the limit switch as a whole when it does not turn off.	Habitual use of the limit switch	Do not use the limit switch habitually.
	Moving part rusted shut	Check the moving part of the limit switch is not stiff. If it is stiff, remove the rust or replace the stiff part.	No use for a long time, use in an environment with rich moisture	Check the electric chain hoist regularly.
	Wrong wiring	Check the wiring in accordance with the wiring diagram. Perform the wiring correctly. If the wiring of the limit switch is correct, the cause is in the negative phase connection. Change two wires of the power line.	Wrong wiring	Correct the wiring in accordance with the wiring diagram.

Troubleshooting (continued)

Push Button Switch

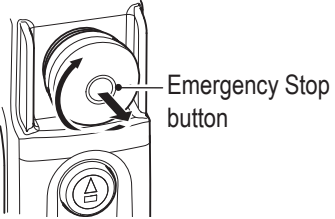
Symptom	Cause	Remedy	Main factor	Countermeasure
Electric chain hoist does not operate.	Emergency Stop button is pressed to its end and locked.	When the Emergency Stop button is pressed and locked, pull the button forward or turn it clockwise to release the lock. 	Forgot releasing the Emergency Stop button	Read "How to Operate the Push Button Switches" (P26) and use the electric chain hoist.
	Faulty switch unit	Check the conduction of the contact points. Replace the Push Button Switch if it has no conduction.	Vibration, impact	Use the electric chain hoist avoiding the impact.
	Breakage inside the switch	Check that the Push Button Switch cord is connected with the switch unit correctly. Repair the cord if it has no conduction.	Vibration, impact	Use the electric chain hoist avoiding the impact.
	Loosened screw to fix the casing	Tighten the screw if loosened	Vibration, impact	Use the electric chain hoist avoiding the impact.
	Wire breakage of Push Button Switch Cord	Check the conduction of the Push Button Switch Cord. If it has no conduction, replace the cable, or the Push Button Switch Cord as a set.	Damage of cable cover	Operate the electric chain hoist not to impede with other facility.
			External force applied on the cable due to improper tying of the protection wire	Tie the protection wire securely. (See "Connecting Cables" (P50).)
The electric chain hoist does not operate as indicated.	Wrong wiring	Check the wiring in accordance with the wiring diagram. Perform the wiring correctly. If the wiring of the Push Button Switch is correct, the cause is in the negative phase connection. Change two wires of the power line.	Wrong wiring	Correct the wiring in accordance with the wiring diagram.
	Wrong affixing of N-E-S-W label	Affix the label in the correct direction.	Affixing the label in an improper direction	Affix the label correctly.
Electric chain hoist does not stop even if the Push Button is released.	Defective return action of the switch unit	Replace the Push Button Switch if it does not operate smoothly.	Vibration, impact	Use the electric chain hoist avoiding the impact.

VFD

Symptom	Cause	Remedy	Main factor	Countermeasure
Electric chain hoist does not operate.	Overload	Inverter stops due to Overload Limiter To resume operation, reset the VFD by pressing Emergency or Lower button.	Overload	Make sure that the load is within the rated load. The ambient temperature is below 0 degree in celsius, operate the chain hoist for a while with no load.
	VFD failure	Reset the VFD by pressing Emergency Stop button. If the VFD still does not operate, check it.	VFD failure	Check the error code indicated by VFD referring to the "VFD Manual".
	Motor overheat	Stop by motor thermal relay function of the VFD. Motor resumes operation when the VFD is reset by pressing the Emergency Stop after cool down.	Operation exceeding intermittent rating	Check the intermittent rating. Use the electric chain hoist within these ratings.
	VFD overheat	Stop by overheat preventive function of the VFD. Motor resumes operation when the VFD is reset by pressing the Emergency Stop after cool down.	Operation exceeding intermittent rating	Check the intermittent rating. Use the electric chain hoist within these ratings.
	Expired service life of the VFD (capacitor)	Refer to the "VFD Manual".	Operation exceeding intermittent rating	Check the intermittent rating. Use the electric chain hoist within these ratings.
The electric chain hoist operates in the direction different to the push button operation (negative phase).	Wrong connection of power line when wiring.	Change two wires of the Motor.	Wrong connection at assembling	Connect wires correctly.
		<div style="border: 1px solid black; padding: 5px;"> <p style="text-align: center; margin: 0;">DANGER</p> <div style="display: flex; align-items: center;"> <div> <ul style="list-style-type: none"> Do not change the connection at the Push Button Switch circuit. <p>The change of circuit at the Push Button Switch circuit is very dangerous as the limit switch becomes not to function.</p> </div> </div> </div>		

HBB Board

Symptom	Cause	Remedy	Main factor	Countermeasure
Electric chain hoist does not operate.	Damaged circuit component	Press the Push Button to check if the main body operates. If it doesn't operate, replace the HBB Board. * Be careful about electric shock when checking energizing..	Service life expiry or damage	Replace the HBB Board.
	Contact failure of connector	Check the conduction of the connector. Replace the connector if it has no conduction.	Defective assembling of the connector	Crimp and insert the connector pins securely.

Braking Resistor

Symptom	Cause	Remedy	Main factor	Countermeasure
Electric chain hoist does not operate.	Resistor breakage	Measure the resistance of the resistor. Replace the resistor if the resistance is infinity.	Operation exceeding intermittent rating, over load	Use the electric chain hoist within the ratings.

(to be continued)

Troubleshooting (continued)

Electric shock

Symptom	Cause	Remedy	Main factor	Countermeasure
Electric shock when touching the body size and Push Button Switch	Improper grounding	Measure the grounding resistance. If it exceeds 100 Ω, perform grounding work in accordance with the relevant laws and regulations.	Defective grounding work	Perform the grounding work securely.
			Contact failure of the grounding wire	Connect the grounding wire securely without loosened screw
			Breakage of grounding wire	Layout the grounding wire to avoid the stress applied on it. (See the item of Power Cable and Push Button Switch.)
	Attachment of waterdrop	Remove the waterdrop, dry the electric chain hoist and then use it.	Operation by wet hand	Do not operate the electric chain hoist by wet hand.

Friction Clutch

⚠ DANGER





- Do not adjust/disassemble the Friction Clutch.

Adjusting or disassembling the Friction Clutch may result in death or serious injury.

Prohibited

Symptom	Cause	Remedy	Main factor	Countermeasure
Unable to lift a load, or the load lowers after stop.	Clutch is activated (normal)	Lighten the load less than the rated load and use the electric chain hoist.	Over load	Use the electric chain hoist with a load less than the rated load.
	Abrasion of Clutch Disk	Replace the Friction Clutch.	Too many use of the Friction Clutch	Avoid the over load.
			Approaching service life limit	Do not use the body size exceeding the service limit.
	Change in mechanical characteristics of the Friction Clutch		Use of oil other than the designated oil	Use KITO genuine oil.
			⚠ DANGER <ul style="list-style-type: none"> • Use KITO genuine gear oil. <p>Use of the oil other than KITO genuine oil may result in death or serious injury due to the drop of a lifted load.</p>	
			Leaving the electric chain hoist for a long time without use	Pay attention to the place to use and the storage place.
Temperature rise inside the gear box	Resume the operation after cool down. When it is still unable to lift a load, replace the Friction Clutch.	Use in a hot environment, or excessively frequent use		Avoid the use in a hot environment or excessively frequent use.

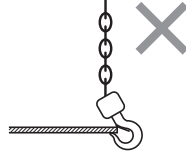
Hook

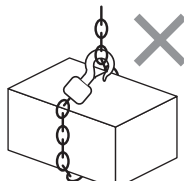
Symptom	Cause	Remedy	Main factor	Countermeasure
Widened Hook opening	Deformation of the Hook	Replace the Hook if the deformation exceeds the criteria. (See P64.)	Over load	Use the electric chain hoist with a load less than the capacity.
			Earth lifting	Do not carry out earth lifting. Be careful not to impede the Hook with protruding object during lifting.
			Slinging a load at the tip of the Hook.  Lateral pulling of the Hook	Slung a load at the center of the Hook
			Improper slinging	Angle formed by two slings must be 120 degrees or less.  120 degrees or less
			Use of the sling with a size improper to the Hook	Use the proper sling.
Twisted hanging of the Hook			Use of the Hook with the Load Chain wound on a load 	Do not wind the Load Chain directly on a load.
Hook unable to swivel smoothly at the neck	Rusting shut or corrosion of Bearing	Swivel the Hook at the neck by hand. If it is difficult to swivel smoothly, overhaul or replace the Bearing.	Insufficient grease application, corrosion due to environment of use	Apply grease regularly. Use the sling to avoid the dipping of the Hook into chemicals.
	Damaged Bearing		Intrusion of dust	Be careful about the intrusion of foreign matter into the neck.

Troubleshooting (continued)

Hook (continued)

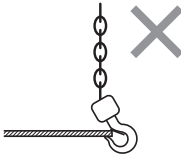
Symptom	Cause	Remedy	Main factor	Countermeasure
Hook Latch has come off	Deformation of the Hook	Replace the Hook if the deformation exceeds the criteria. (See P72.)	Over load	Use the electric chain hoist with a load less than the capacity.
			Earth lifting	Do not carry out earth lifting. Be careful not to impede the Hook with protruding object during lifting.
			Use of the sling with a size improper to the Hook	Use the proper sling.
	Deformation and come-off of the Hook Latch	Replace the Hook Latch if it has come off or is deformed.	Sling put on the Hook Latch	Do not put the sling on the Hook Latch.
Hook bent at the neck (shank)	Deformation or damage of the Hook at its neck	Replace the Hook bent at the neck.	Lifting a load at the tip of the Hook  Lateral pulling of the Hook	Sling a load at the center of the Hook
Hook unable to swivel smoothly at the neck	Rusting shut or corrosion of Bearing	Swivel the Hook at the neck by hand. If it is difficult to swivel smoothly, overhaul or replace the Bearing.	Insufficient grease application, corrosion due to environment of use	Apply grease regularly. Use the sling to avoid the dipping of the Hook into chemicals.
	Damaged Bearing		Intrusion of dust	Be careful about the intrusion of foreign matter into the neck.

Load Chain

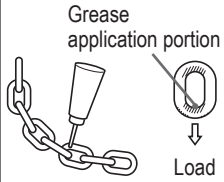
Symptom	Cause	Remedy	Main factor	Countermeasure
Twisted Load Chain	Load Chain is twisted inside the main body of the electric chain hoist.	Remove the Chain Guide and the Load Chain, and then reassemble them.	Improper assembling	Assemble the electric chain hoist correctly. (See Disassembling/Assembling Manual)
Sudden activation of the Friction Clutch when lowering	Knot of the Load Chain due to entanglement in the Chain Container	Check the capacity of the Chain Container (with the nameplate on the Chain Container). If insufficient, replace the Chain Container with a larger capacity.	Insufficient capacity of the Chain Container	When installing the electric chain hoist, check the lift and the capacity of the Chain Container, and assemble them correctly.
Sounds the popping sound	Abrasion of the Load Chain links	Measure the abrasion of wire diameter. Replace the Load Chain if it reaches at the abrasion limit. (See P73)	Long hour operation without grease	Apply lubricant regularly. (See P37) 
			Excessive inching operation	Do not perform excessive operation.
			Over load	Use the electric chain hoist with a load less than the capacity.
			Pulling a load in an inclined direction	Do not pull a load in an inclined direction.
	Elongation of pitch	Measure the sum of pitches of 5 links. Replace the Load Chain if this value exceeds the limit value. (See P65)	Over load	Use the electric chain hoist with a load less than the capacity.

Troubleshooting (continued)

Load Chain (continued)

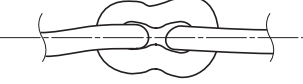
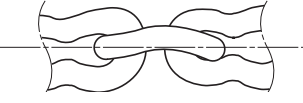
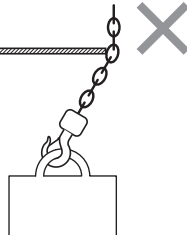
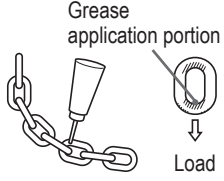
Symptom	Cause	Remedy	Main factor	Countermeasure
Irregular noise	Flaw and deformation of the Load Chain surface	Replace the Load Chain with apparent flaw or deformation. 	Use of the Load Chain without canceling capsized state	When using multi fall model hoist, check that the Hook is not capsized before use.
	Hit flaw on the Load Chain surface		Use of the Load Chain as twisted	Assemble the electric chain hoist correctly. (See Disassembling/Assembling Manual)
			Hit with other object strongly 	Use the electric chain hoist carefully paying attention not to impede with other object.
Surface losing lust and discolored	Rusting and corrosion	Remove rust and apply oil. Replace the Load Chain if the rust and corrosion is apparent.	Run-out of oil	Apply lubricant regularly. (See P37) 
			Use of electric chain hoist exposed to rain	Store the electric chain hoist indoor or under the roof when not using.
			Influence of sea water and chemicals	Contact KITO for the use in special environment in advance. Use the electric chain hoist correctly within the scope guaranteed by the manufacturer.
Breakage of the Load Chain	Expiry of the service life	Check the Load Chain and replace it if exceeded the criteria. (See P65)	Mechanical service life expiry	Handle the Load Chain correctly and perform the appropriate control including daily inspection and inspection.

Load Sheave

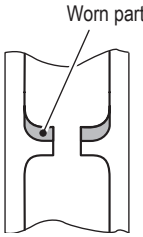
Symptom	Cause	Remedy	Main factor	Countermeasure
Sounds popping sound	Abrasion of sheave pocket or flaw by the Load Chain out of mesh with the Sheave 	Measure the thickness of the crest. Replace the Sheave if the thickness is less than the criteria. (See P77) The Load Chain may be worn. Check also the Load Chain.	Long hour operation without grease, expiry of service life	Apply lubricant regularly. (See P37)
			Excessive inching operation	Do not perform excessive operation.
			Over load	Use the electric chain hoist with a load less than the capacity.
			Pulling a load in an inclined direction	Do not pull a load in an inclined direction.

Chain Guide

Symptom	Cause	Remedy	Main factor	Countermeasure
Swinging of a load became larger than when purchasing	Abrasion of cross guide	Measure the standard dimension. Replace the Chain Guide if the standard dimension exceeds the criteria. (See P72) The Load Chain may be worn. Check also the Load Chain.	Pulling a load in an inclined direction	Do not pull a load in an inclined direction.

Gears

Symptom	Cause	Remedy	Main factor	Countermeasure
Unable to lift a load.	Abrasion, Damage	Replace gear or joint if it is worn apparently or damaged	Long hour operation without oil <div style="border: 1px solid black; padding: 5px; margin-top: 10px;"> <p style="text-align: center;">⚠ DANGER</p> <p>! Mandatory • Use KITO genuine gear oil. Use of the oil other than KITO genuine oil may result in death or serious injury due to the drop of a lifted load.</p> </div>	Keep the oil change cycle. (See P86)
Irregular motion	Partial abrasion or damage		Too many use of the Friction Clutch	Avoid the over load.
			Habitual use of Upper/Lower Limit Switch	Do not use Upper/Lower Limit Switch habitually.

Troubleshooting (continued)**Bearing**

Symptom	Cause	Remedy	Main factor	Countermeasure
Unable to lift a load.	Sticking, Breakage	Replace the bearing.	Use under hot environment or excessively frequent use	Avoid using under hot environment or excessively frequent use
Strange noise	Deterioration	Replace the bearing.	Use under hot environment or excessively frequent use	Avoid using under hot environment or excessively frequent use

Traveling motion of the Trolley (common for motorized/manual trolley)

Symptom	Cause	Remedy	Main factor	Countermeasure
Unable to travel due to slipping of wheel	Inclination of Travel Rail	Make sure that rail gradient is within 1 degree.	Improper installation of Travel Rail	Install the Travel Rail correctly.
Unable to travel due to slipping of wheel, or unable to travel in uniform motion	Oil attachment on running surface of the rail	Wipe off the attached foreign matter of the rail.	Use under the environment likely to attach foreign matter	Clean the Travel Rail regularly.
Sounds abrasion sound when running on a curved rail	Friction resistance between wheel and rail	Apply small amount of grease on the rail surface where noise generates.		
Unable to travel on the curved rail	Interference of the trolley and the curved rail	Make sure that the rail curvature is larger than the minimum turning radius. (See P39-40, 43-45)	Use of the curved rail of curvature less than minimum turning radius	Do not use the curved rail of curvature less than minimum turning radius
Unable to travel due to wheel floating	Pulling a load in an inclined direction (floating wheel)	—	Operating method	Use the electric chain hoist correctly.
Wheel unable to rotate	Defective gear engagement	Remove the stain and foreign matter on the wheel and the gear.	Ambient conditions, environment	Check regularly.
Serpentine motion Strange noise	Wrong adjustment of spacer	Check the number of spacers and their assembled positions.	Incomplete checking	Assemble correctly.
	Uneven abrasion of the wheel	Check the abrasion of the wheel.	Traveling on curved rail or unevenness of running surface	Check regularly.
	Deformation of wheel	Check the distortion of wheel and damage of running surface.	Excessively frequent collision with stopper or unevenness of running surface	Replace the wheel Use the electric chain hoist correctly.
	Deterioration of wheel bearing	Check if rolling noise sounds when the wheel is rotating.	Expiry of service life	Replace the wheel bearing.
	Deformation and abrasion of the rail	Check the abrasion and deformation of the rail.	Over load or expiry of service life	Replace the rail. Use the electric chain hoist correctly.

Traveling motion of the Trolley (only for motorized trolley)

Symptom	Cause	Remedy	Main factor	Countermeasure
Wheel unable to rotate	Locking of brake	Disassemble the motor cover. Remove rust and stains.	Ambient conditions, environment	Check regularly.
	Electric system failure (Refer to the items of Electric chain hoist)	(Refer to the items of Electric chain hoist)		
Serpentine motion Strange noise	Abrasion of the side roller	Check the abrasion	Traveling on curved rail or expiry of service life	Check regularly.
	Abrasion of the Brake Pad	Check the abrasion of the Brake Pad	Expiry of service life	Check regularly.

Appendix

■Wiring Diagram

EQ Wiring Diagram (230V Class, 400V Class)	112
MR2Q Wiring Diagram (230V Class, 400V Class)	113

■Part List

Model EQ

- Body, gear case, motor
- Electric, component and chain

Model MR2Q

- Frame and wheel, motor, gear
- Connection box related.....
- Push button and cable related

Wiring Diagram

EQ Wiring Diagram (230V Class, 400V Class)

Parts No	NAME
1	M11 Hoist Motor
2	INV1 Inverter
3	HBB_BRD1 HBB Board
4	PH1 Photo Coupler
5	C1 Capacitor
6	LS11 Upper Limit Switch
7	LS12 Lower Limit Switch
8	R~ Resistor
9	CN~ Connector

Abbreviation	
Bk : Black	Gn / Ye : Green & Yellow
Rd : Red	
Wh : White	EM : Emergency Stop
Be : Blue	UP : UP
Bn : Brown	DN : Down

Note

1. Operation Type
Hoist: Dual Speed (Inverter)
2. Power Supply
200V class, 400V class
50/60Hz, 3Phase
3. Push Button Connection
Direct Connection
Control Circuit Voltage: DC24V

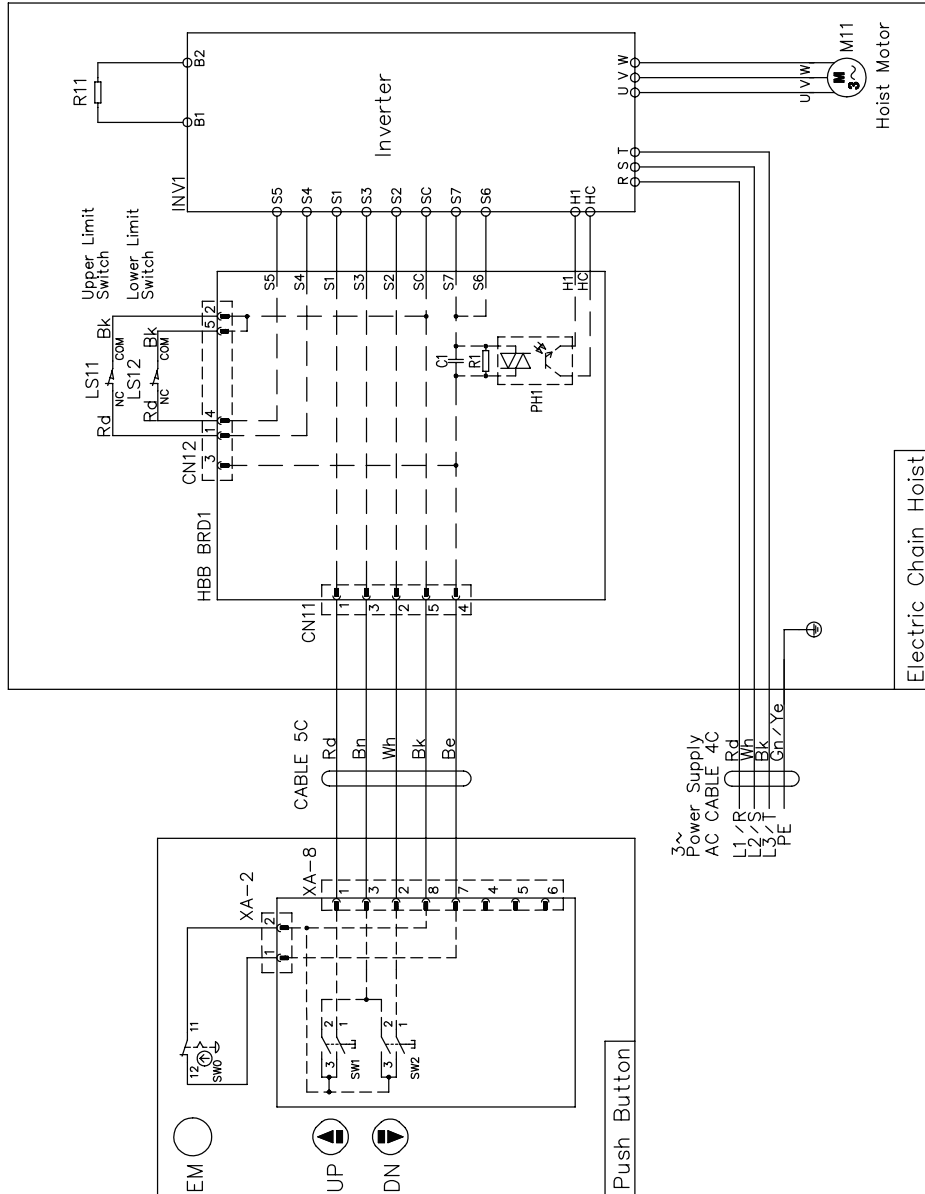

MR2Q Wiring Diagram (230V Class, 400V Class)

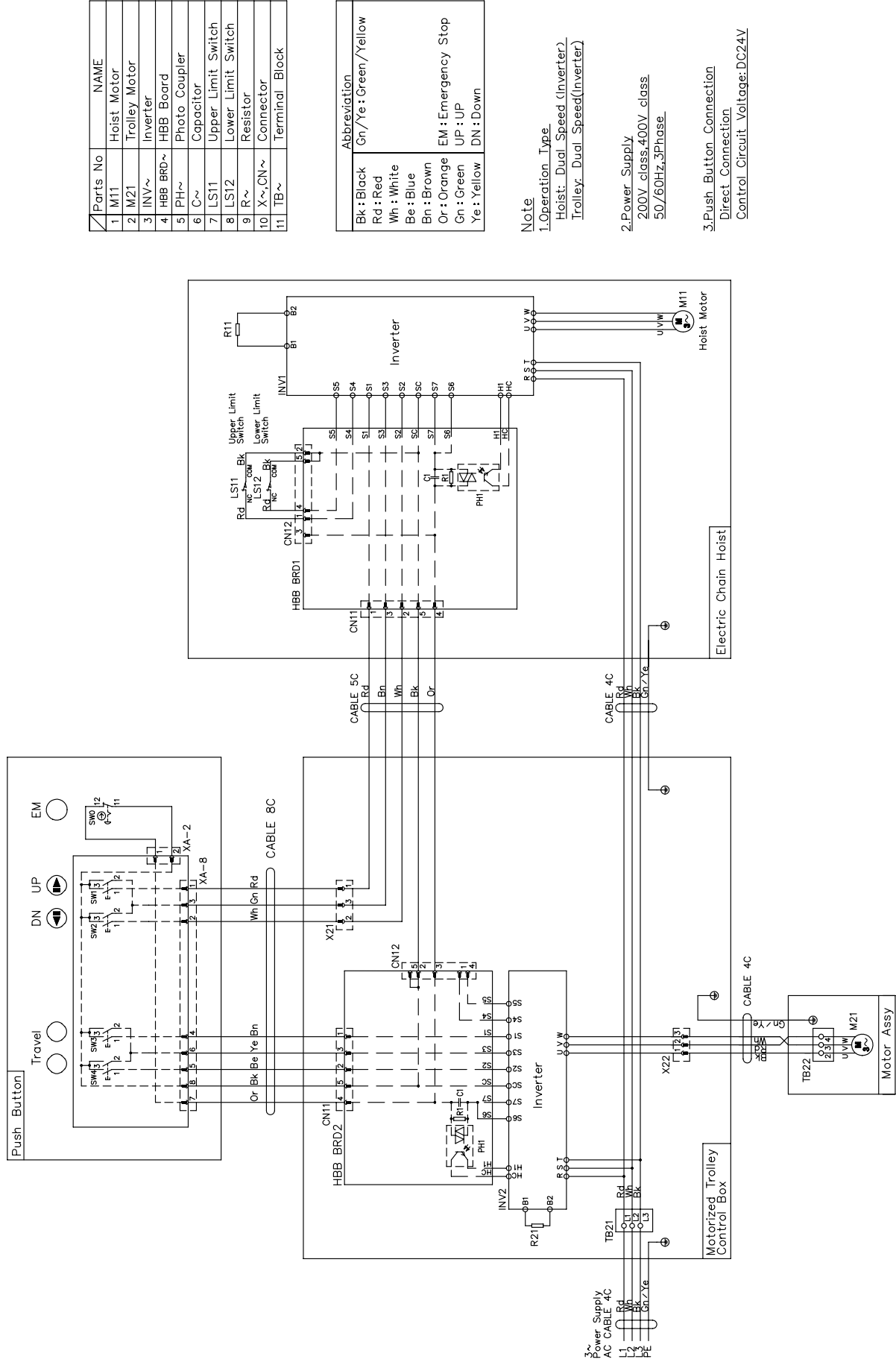

Parts No	NAME
1 M11	Hoist Motor
2 M21	Trolley Motor
3 INV~	Inverter
4 HBB BRD~	HBB Board
5 PH~	Photo Coupler
6 C~	Capacitor
7 LS11	Upper Limit Switch
8 LS12	Lower Limit Switch
9 R~	Resistor
10 X~,CN~	Connector
11 TB~	Terminal Block

Abbreviation
Bk : Black
Rd : Red
Wh : White
Be : Blue
Bn : Brown
Or : Orange
Gn : Green
Ye : Yellow

EM : Emergency Stop
UP : UP
DN : Down

- Note**
1. Operation Type
Hoist: Dual Speed (Inverter)
Trolley: Dual Speed (Inverter)
 2. Power Supply
200V class, 400V class
50/60Hz, 3Phase
 3. Push Button Connection
Direct Connection
Control Circuit Voltage: DC24V

Parts List

■ Body, gear case, motor

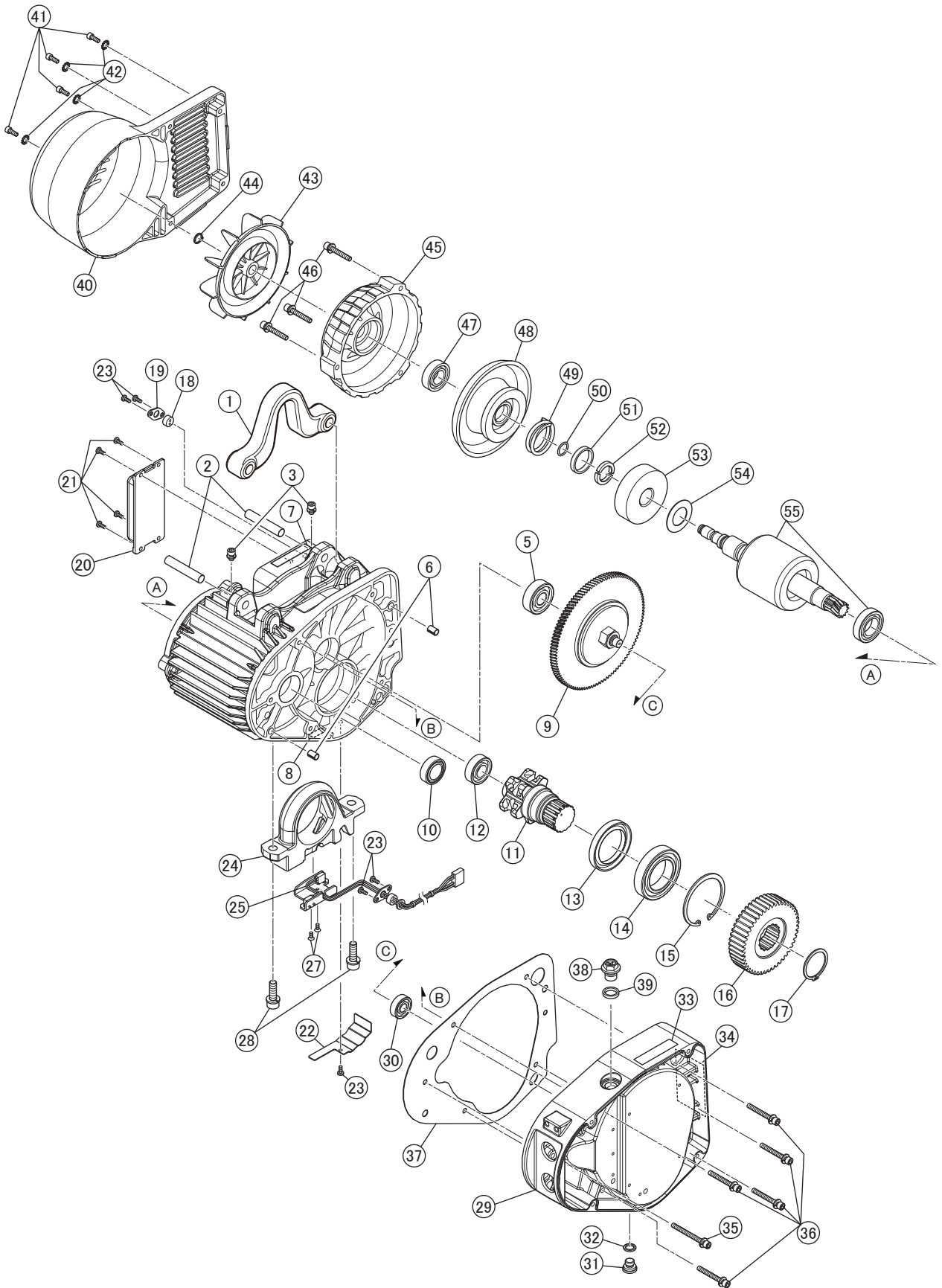

Figure #	Part Number	Part Name	Quantity per unit	Part Code				Remark
				EQ001IS	EQ003IS	EQ004IS EQ005IS	EQ010IS	
1	001	Suspension Eye	1	EQ1C19001	←	←	EQ1D19001	For KITO EQ trolley connection
2	121	Top pin	2	EQ1C19121	←	←	EQ1D19121	
3	033	Machine screw socket bolt	2	J1BG1-0601010	←	←	←	For Top pin
5	238	Ball bearing	1	J1GR000-06202	←	←	J1GR0A0-06303	
6	137	Set pin S	2	E6SE005S9120	←	←	←	
7	820	Warning sticker HW	1	EQ1D19806	←	←	←	
8	960	Name plate side E	1	ER1BS9960	←	←	←	
9	1223	Friction clutch complete set	1	EQ1CG1223	EQ1CF1223	EQ1C11223	EQ1D11223	
10	244	Oil seal	1	EQ1C19244	←	←	EQ1D19244	For Motor shaft
11	241	Load sheave	1	EQ1C19241	←	←	EQ1D19241	
12	242	Ball bearing	1	J1GR0C0-06005	←	←	J1GR0C0-06006	For Load sheave
13	245	Oil seal	1	EQ1C19245	←	←	EQ1D19245	For Load sheave
14	243	Ball bearing	1	J1GR0A0-06007	←	←	J1GR0A0-06009	For Load sheave
15	207	Snap ring	1	JISR000-00062	←	←	JISR000-00075	For Bearing (load side)
16	240	Load gear	1	EQ1CG9240	EQ1CF9240	EQ1C19240	EQ1D19240	
17	208	Snap ring	1	JISS000-00034	←	←	JISS000-00040	For Load gear
18	187	Packing	1	EQ1D19187	←	←	EQ1D19187	
19	153	Cable holder	1	EQ1D19153	←	←	←	
20	5505	Braking resistor assembly	1	INV705Y16	←	INV705Y16 *	INV715Y17 *	400V Class
			1	INV705E16	←	INV705E16 *	INV715E16 *	230V Class
21	194	Machine screw with spring washer	2	J1AP2-4001010	←	←	X	For Braking resister
			4	X	X	X	J1AP2-4001010	
22	151	Limit switch cord cover	1	EQ1C19151	←	←	EQ1D19151	
23	152	Machine screw with spring washer	5	J1AP2-4001010	←	←	←	For Limit switch cord cover, Cable holder
24	331	Chain guide	1	EQ1C19331	←	←	EQ1D19331	
25	1333	Limit switch assembly	1	EQ1C11333	←	←	EQ1D11333	
27	335	Machine screw	2	J1AL2-4001010	←	←	←	
28	165	Machine screw socket bolt	2	J1BG1-0802525	←	←	J1BG1-1003030	For Chain guide
29	110	Gear case	1	EQ1C19110	←	←	EQ1D19110	
30	239	Ball bearing	1	J1GR0A0-06200	←	←	J1GR0A0-06201	
31	133	Oil plug	1	E5FE003S9111	←	←	E5FE003S9111	
32	136	Plug packing	1	E2YS005-9109	←	←	←	
33	810	Name plate OF	1	ER2CS9845	←	←	←	
34	815	Name plate SP	1	EQ1BGY1019B61	←	←	←	For LOT No. EQ1A, EQ1B
			1	EQ1BGY1019B62	←	←	←	For LOT No. EQ1C
35	167	Machine screw socket bolt	1	J1BG1-0603030	←	←	←	For Gear case
36	162	Machine screw socket bolt	5	J1BG1-0605050	←	←	←	For Gear case
37	116	Packing G	1	EQ1C19116	←	←	EQ1D19116	
38	135	Oil plug B	1	WR2BS9135	←	←	←	
39	173	Eyebolt packing	1	E2YS005-9116	←	←	←	
40	107	Fan cover	1	EQ1C19107	←	←	EQ1D19107	
41	164	Socket bolt	4	J1BE1-0501414	←	←	←	For Fan cover
42	225	Toothed lock washer	4	J1WH012-10050	←	←	←	For Fan cover
43	108	Fan	1	ER2BS9108	←	←	ER2CS9108	
44	323	Snap ring	1	J1SS000-00013	←	←	←	
45	106	Motor cover	1	EQ1C19106	←	←	EQ1D19106	
46	163	Machine screw socket bolt	3	J1BG1-0605050	←	←	J1BG1-0604040	For Motor cover
47	209	Ball bearing	1	J1GR0C0-06203	←	←	J1GR0C0-06004	
48	5212	Brake drum assembly	1	EQ1C15212	←	←	EQ1D15212	
49	214	Brake spring	1	EQ1CF9214	←	EQ1C19214	EQ1D19214	
50	324	O ring	1	J1OP011-00125	←	←	J1OP011-00160	
51	318	Collar	1	E5FE003S9506	←	←	E5FE005S9506	
52	317	Thrust disc	2	E5FE003S9505	←	←	E5FE005S9505	
53	503	Pull rotor	1	E5FE003S9503	←	←	E5FE005S9503	
54	316	Coned disc spring	1	E5FE003S9504	←	←	E5FE005S9504	
55	5502	Motor shaft assembly	1	EQ1CF55022	←	EQ1C155022	EQ1D155021	For LOT No. EQ1A, EQ1B
			1	EQ1CF55023	←	EQ1C155023	EQ1D155022	For LOT No. EQ1C

*Braking resistor assembly for EQ004IS, EQ005IS, EQ010IS of LOT No. EQ1A has been changed.
When replacing Braking resistor assembly of LOT No. EQ1A, replace with Inverter assembly together.
See page 117.

Electric, component and chain

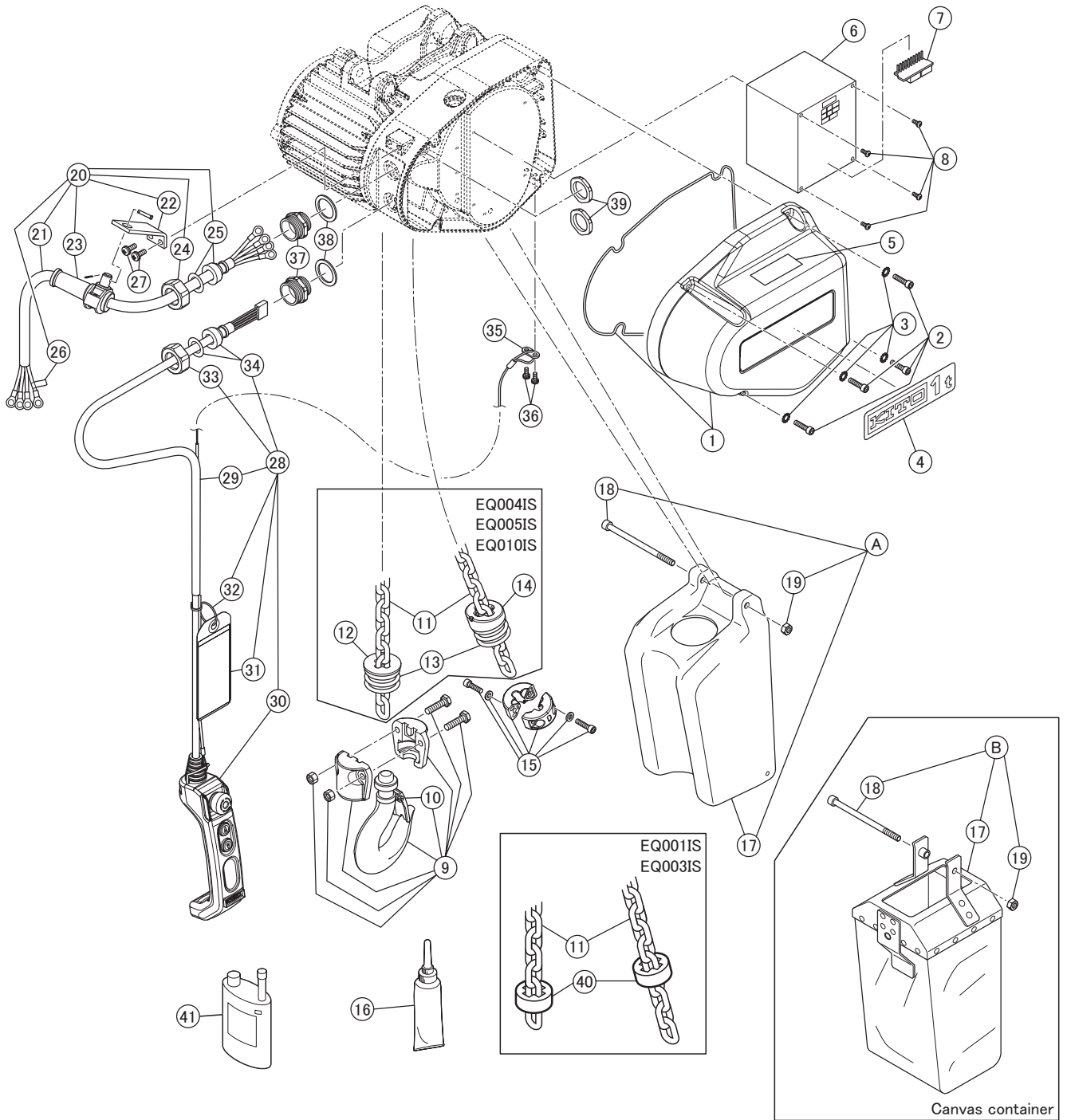
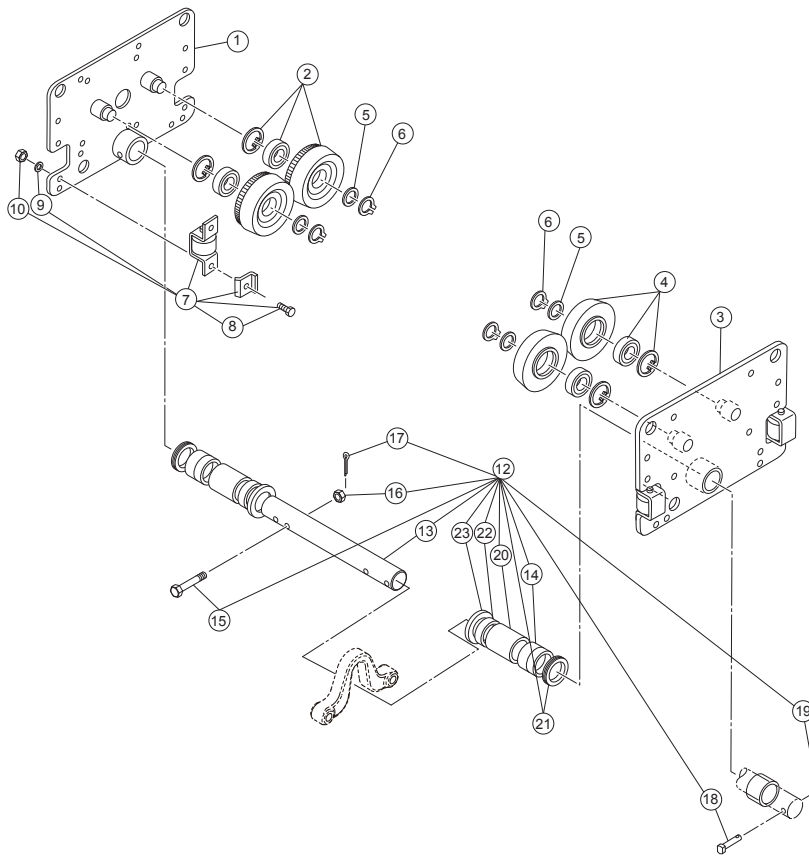

Figure #	Part Number	Part Name	Quantity per unit	Part Code				Remark
				EQ001IS	EQ003IS	EQ004IS EQ005IS	EQ010IS	
1	2104	Controller cover assembly	1	EQ1C12104	←	←	EQ1D12104	
2	161	Socket bolt	4	J1BE1-0602525	←	←	←	For Controller cover
3	224	Toothed lock washer	4	J1WH012-10060	←	←	←	For Controller cover
4	800	Name plate B	1	EQ1BUQ0119A3	EQ1BUQ0319A3	EQ1BEE0419A3 (490kg)	EQ1BUQ1019A3	
5	866	Warning sticker E	1	E2DPX10S9866	←	←	←	
6	1571	Inverter assembly	1	INV60FY44	INV60FY41	X	X	400V Class For LOT No. EQ1A
				INV60FC44	INV60FC41	X	X	230V Class For LOT No. EQ1A
				X	X	INV60FY47*	INV615Y44*	400V Class For LOT No. EQ1B
				X	X	INV60FC47*	INV615C44*	230V Class For LOT No. EQ1B
				INV60FY54	INV60FY51	INV60FY57	INV615Y54	400V Class For LOT No. EQ1C
				INV60FC54	INV60FC51	INV60FC57	INV615C54	230V Class For LOT No. EQ1C
7	508	HBB board	1	ECP91KB22	←	←	←	
8	191	Machine screw with spring washer	4	J1AP2-4001010	←	←	←	400V Class
				X	X	X	J1AP2-4001010	230V Class
				J1AP2-4001010	←	←	X	230V Class
9	1011	Bottom hook complete set	1	X	X	EQ1C11035 (490kg)	X	
				EQ1CG1011	EQ1CF1011	EQ1C11011 (500kg)	EQ1C11011	
10	1002	Hook latch assembly	1	ER2CS9002	←	←	ER2DS1002	
11	874	Load chain	1	KAZN056W0000	←	←	←	
12	054	Limiting plate	1	X	X	EQ1C19054	EQ1D19054	
13	051	Chain spring	2	X	X	EQ1C19051	EQ1D19051	
14	055	Spring guide	1	X	X	EQ1C19055	EQ1D19055	
15	1041	Stopper assembly	1	ER1CS1041	←	←	ER1DS1041	
16	1951	Lubricant tube assembly	1	ER2CS1951	←	←	←	
(A)	1401	Chain container P complete set	1	EQ1C11401	←	←	EQ1D11401	Plastic container
17	401	Chain container P	1	EQ1C19401	←	←	EQ1D19401	
18	166	Socket bolt	1	J1BE1-0809028	←	←	J1BE1-0812028	For Chain container
19	226	Lever nut	1	C2BA100-9074	←	←	←	For Chain container
(B)	1405	Chain container (15) complete set	1	EQ1C11405	←	←	x	Canvas container
17	5405	Chain container (15) assembly	1	EQ1C15405	←	←	x	
18	166	Socket bolt	1	J1BE1-0809028	←	←	x	For Chain container
19	226	Lever nut	1	C2BA100-9074	←	←	x	For Chain container
20	1521	Power supply cable assembly	1	ZLZB11CQ1000	←	←	←	
				ZLZB11AQ1000	←	←	←	Cable one size larger than the standard size
21	521	Cable	1	Z2CU401-0000	←	←	←	
				Z2CU402-0000	←	←	←	Cable one size larger than the standard size
22	541	Cable support arm	1	ER1BS9541	←	←	←	
23	1542	Cable support 12 assembly	1	E7AX003S2822	←	←	←	
		Cable support 14 assembly		E4YS005-2822	←	←	←	Cable one size larger than the standard size
24	569	Holder A	1	ECP5924AA	←	←	←	
25	574	Cable packing	1	ECP6912AA	←	←	←	
				ECP6914AA	←	←	←	Cable one size larger than the standard size
26	823	Name plate G	1	E6LE010S9806	←	←	←	
27	542	Machine screw with spring washer	2	J1AP2-6001616	←	←	←	For Cable support arm
28	1557	Push button cord EH complete set	1	ZLD0015W1000	←	←	←	
29	557	Cable	1	Z3CA500-0000	←	←	←	
30	1561	3 push button switch assembly	1	SWJ2200AA	←	←	←	
31	565	Warning tag PB	1	SWD9013AB	←	←	←	
32	566	Tag holder	1	E7SE003S9787	←	←	←	
33	569	Holder A	1	ECP5924AA	←	←	←	
34	574	Cable packing	1	ECP6910AA	←	←	←	
35	535	Cord support (wire stopper)	1	ER1BS9534	←	←	←	
36	536	Machine screw with spring washer	2	J1AP2-5001212	←	←	←	For Cord support
37	891	Holder B	2	ECP5924AB	←	←	←	
38	892	Holder packing	2	ECP5924AQ	←	←	←	
39	893	Holder nut	2	ECP5924AD	←	←	←	
40	053	Cushion rubber	2	ER1CS9053	←	x	x	
41	1855	Oil pot F	1	ER1BS1855	←	←	ER1CS1855	

* Inverter assembly for EQ004IS, EQ005IS, EQ010IS of LOT No. EQ1A has been changed into LOT No. EQ1B use.
When replacing Inverter assembly of LOT No. EQ1A, replace with Braking resistor assembly together. See page 115.

■ Frame and wheel, motor, gear

<Frame and wheel, suspension shaft>



<Motor, gear>

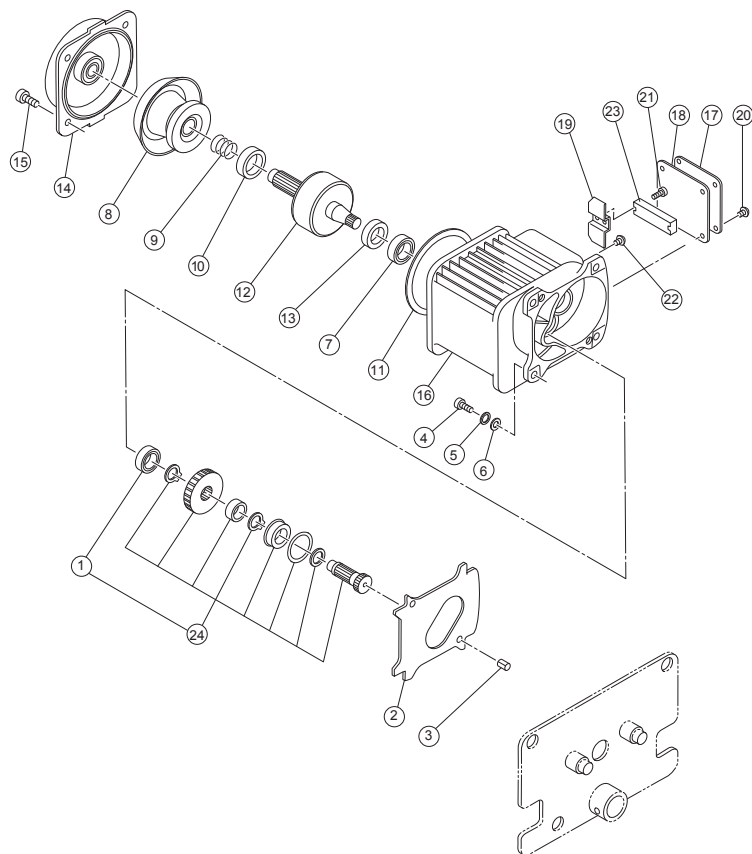

Frame and wheel, suspension shaft

In Diagram	Part Number	Part Name	Quantity per unit	Part Code	Remark
				MR2Q010IS	
1	5201	Side plate G assembly	1	MR1DS5201	
2	1231	Track wheel G assembly	2	M6SE010S1101	
3	5202	Side Plate S assembly	1	MR1DS5202	
4	1232	Track wheel S assembly	2	M6SE010S1102	
5	235	Washer	4	T6GA010-9104	For track wheel G,S
6	236	Snap ring	4	J1SS000-00015	For track wheel G,S
7	1211	Side roller complete set	4	MR1DS1211SU_01	
8	219	Bolt	8	J1BA1-0803030	
9	220	Spring lock washer	8	J1WS011-20080	
10	221	Nut	8	J1NA001-20080	
12	2135	Suspension shaft complete set (150)	1	MR2DI2135	125kg-500kg, Beam width: 58-153mm
	2101			MR2DI2111	1t, Beam width: 58-153mm
13	101	Suspension shaft (125)	1	M7SE010S9115	
14	102	Thick spacer	5	T4GA010-9116	
15	103	Bolt	1	T1GA010-9153	
16	104	Slotted nut	1	J1NL002-10100	
17	105	Split pin	1	J1PW01-025018	
18	106	Shaft stopper	1	T6GA020-9156	
19	107	Split pin	1	J1PW02-040020	
21	109	Thin spacer	8	T6GA020-9117	125kg-500kg
			14		1t
22	110	Thick spacer L	2	MR1DS9110	125kg-500kg
23	113	Thin spacer L	2	MR2DI9113	
12	1136	Suspension shaft complete set (300)	1	MR2DI1136	125kg-500kg, Beam width: 154-305mm
	1121			MR2DI1112	1t, Beam width: 154-305mm
13	121	Suspension shaft (300)	1	M7SE010S9181	
14	102	Thick spacer	9	T4GA010-9116	
15	103	Bolt	1	T1GA010-9153	
16	104	Slotted nut	1	J1NL002-10100	
17	105	Split pin	1	J1PW01-025018	
18	106	Shaft stopper	1	T6GA020-9156	
19	107	Split pin	1	J1PW02-040020	
20	108	Fixing spacer (300)	2	M7SE010S9182	
21	109	Thin spacer	8	T6GA020-9117	125kg-500kg
			14		1t
22	110	Thick spacer L	2	MR1DS9110	125kg-500kg
23	113	Thin spacer L	2	MR2DI9113	

Motor, gear

In Diagram	Part Number	Part Name	Quantity per unit	Part Code	Remark
				MR2Q010IS	
2	248	Gear frame packing	1	MR1DS9248	
3	249	Set pin	2	MR1DS9249	For gear frame and frame G
4	250	Bolt	4	J1BA1-0802525	For gear frame. Integrated type with spring/flat washer is available. (251 and 252 are not necessary.)
5	251	Spring lock washer	4	J1WS011-20080	For gear frame
6	252	Washer	4	J1WA011-00080	For gear frame
7	253	Ball bearing	1	J1GR0C0-06204	For gear frame on motor side
8	5261	Brake drum assembly	1	MR1DS5261	
9	264	Brake spring	1	M3ES010-9304	
10	265	Bumper	1	MR1DS9265	
11	281	Guard	1	MR1DS9281	
12	5291	Motor shaft with rotor	1	MR1DS5291	
13	293	Oil seal	1	MR1DS9293	
14	1301	Motor cover assembly	1	MR1DS1301	
15	304	Socket bolt	4	J1BE1-0802222	For motor cover
16	5321	Motor frame with stator	1	MR2SJY10S5A2	400V Class
				MR2SJC10S5A2	230V Class
17	324	Terminal cover	1	M6FE005S9206	
18	325	Terminal cover packing	1	MR1DS9325	
19	326	Coil cover	1	MR1DS9326	
20	331	Machine screw with spring washer	4	J1AP2-5001010	For terminal cover
21	332	Machine screw with spring washer	2	J1AW2-4002020	For terminal plate
22	334	Machine screw with spring washer	1	J1AP2-4000808	For ground
23	851	Terminal 6P	1	M6FE005S9516	
24	1241	Gear complete set	1	MR1DS1241	
1	247	Ball bearing	1	J1GR0B0-06002	For gear #3 on gear frame side

■ Connection box related

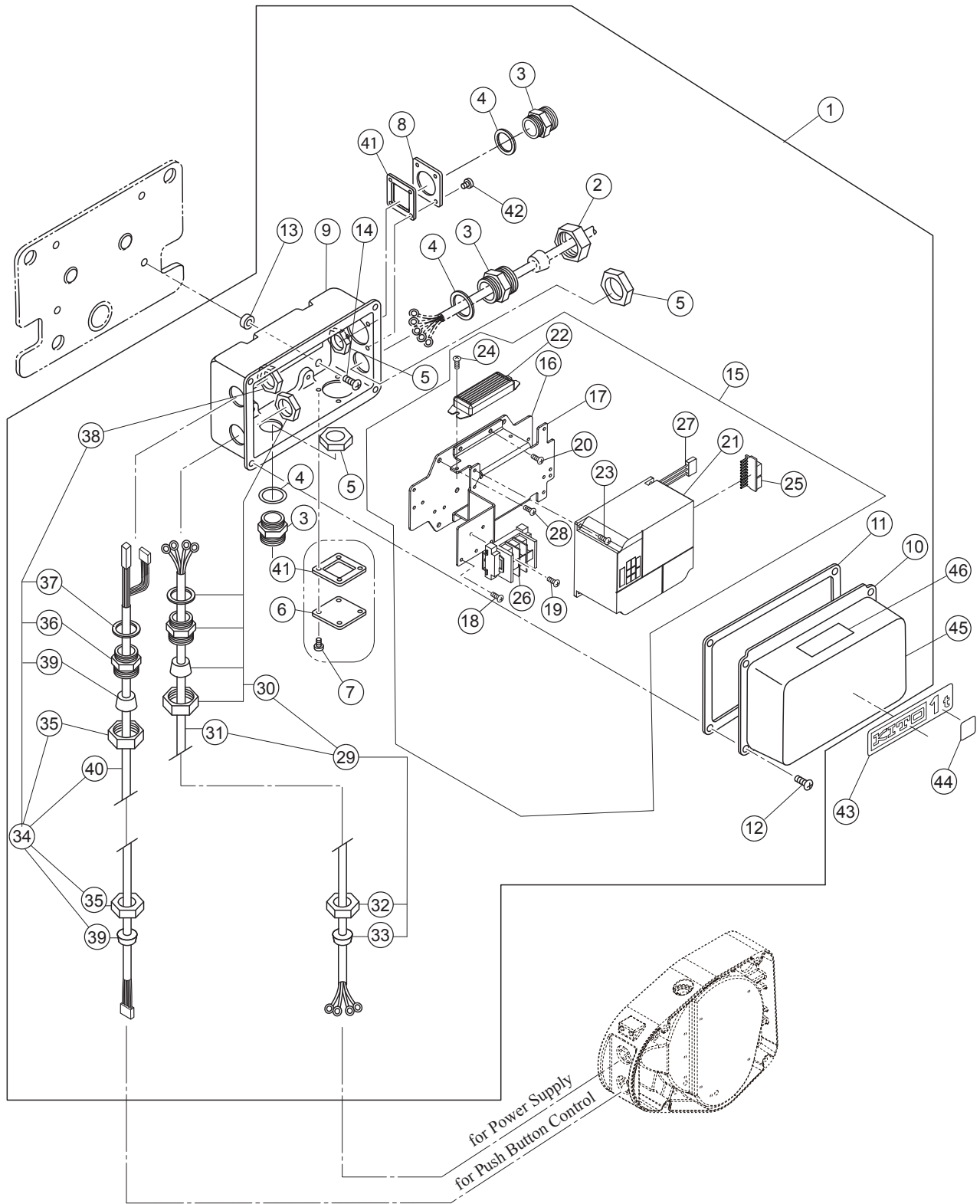

In Diagram	Part Number	Part Name	Quantity per unit	Part Code	Remark
				MR2Q010IS	
1	1401	Connection box complete set	1	MR2IVD10R1A4	400V Class
				MR2IVE10R1A4	230V Class
2	341	Holder A	1	ECP5924AA	
3	342	Holder B	3	ECP5924AB	
4	343	Packing	3	ECP5924AC	
5	344	Holder nut	3	ECP5924AD	
6	347	Cord cover	1	E6LE010S9630	
7	348	Machine screw with spring washer	4	J1AP2-5000808	For Cord cover
8	349	Plate D	1	ECP5924AF	
9	401	Connection box	1	MR1DS9401	
10	411	Connection box cover	1	MR1DS9411	
11	421	Connection box packing	1	MR1DS9421	
12	422	Machine screw with spring washer	4	J1AP2-5001010	For Connection box cover
13	423	Spacer	4	M6SE010S9517	
14	424	Machine screw with spring washer	4	J1AP2-8002020	For connecting Connection box and Frame
15	1445	Plate complete set	1	MR2IVD10R1A5	400V Class
				MR2IVE10R1A5	230V Class
16	441	Plate	1	MR2DI9441	
17	443	Plate B	1	MR2DI9443	
18	451	Machine screw with spring washer	3	J1AP2-4000808	For grounding
19	452	Machine screw with spring washer	2	J1AW2-4000808	For Terminal 3P
20	467	Machine screw with spring washer	4	J1AP2-4000808	For Plate B
21	1571	Inverter assembly	1	INV602Y31	400V Class
				INV604C31	230V Class
22	573	Braking resistor	1	INV904Y34	400V Class
				INV904E34	230V Class
23	580	Machine screw with spring washer	4	J1AP2-4001010	For inverter, 400V Class
					2
24	581	Machine screw with spring washer	2	J1AW2-4000808	For Braking resistor
25	716	HBB board	1	ECP91KB22	
26	853	Terminal 3P	1	ECP1403AA	
27	863	Inverter lead wire	1set	MR2IVA10R9A5	
28	454	Machine screw with spring washer	4	J1AP2-5001010	For Plate complete set
29	1751	Relay cable P assembly	1	MR2DS2760	For power supply
30	1570	Holder assembly	1	ECP5924BA	
31	751	Cable	1	Z2CU401-0000	
32	341	Holder A	1	ECP5924AA	
33	351	Cable packing	1	ECP6912AA	
34	1761	Relay cable S assembly	1	MR2DI2766	For operation
35	341	Holder A	2	ECP5924AA	
36	342	Holder B	1	ECP5924AB	
37	343	Packing	1	ECP5924AC	
38	344	Holder Nut	1	ECP5924AD	
39	351	Cable packing	2	ECP6910AA	
40	761	Cable	1	Z2CA500-0000	
41	818	Cord cover packing	2	M7SE010S9527	
42	820	Machine screw with spring washer	4	J1AP2-5000808	For Plate D
43	701	Name plate B	1	EQ1BEE04I9A3	490kg
				EQ1BUQ10I9A3	1t
44	702	Name plate D	1	EQ1BUQ01I9A6	125kg [Affixed on Name plate B (1t)]
				EQ1BUQ03I9A6	250kg [Affixed on Name plate B (1t)]
				EQ1BUQ05I9A6	500kg [Affixed on Name plate B (1t)]
45	834	Name plate SP	1	MR2IVD10R9B7	
46	711	Warning seal E	1	ER2CS9937	Electric shock

■ Push button and cable related

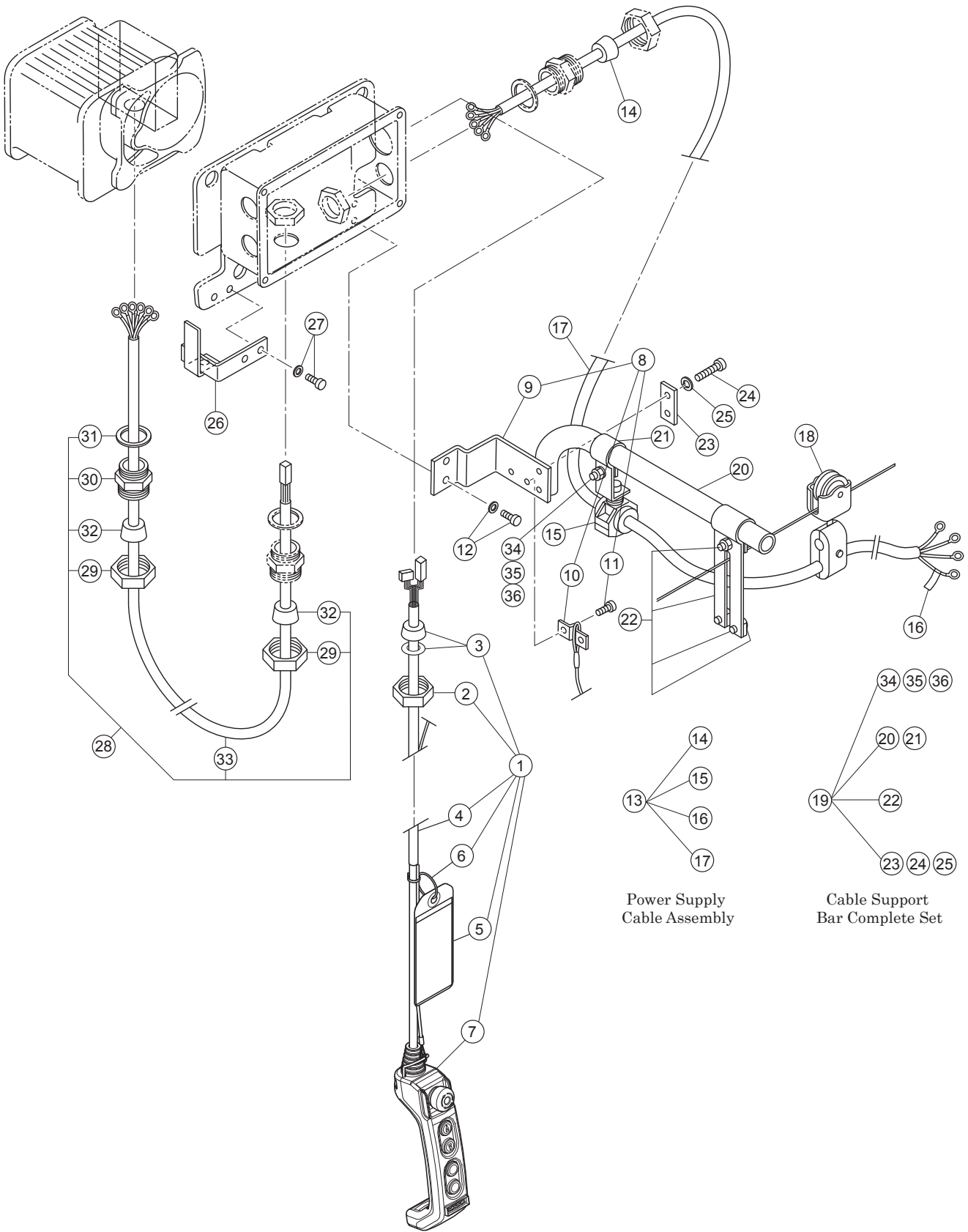

Appendix

A

Push button and cable related

In Diagram	Part Number	Part Name	Quantity per unit	Part Code	Remark
				MR2Q010IS	
1	1781	Push button cord TR complete set	1	ZLDD01AW1000	
2	341	Holder A	1	ECP5924AA	
3	351	Cable packing	1	ECP6912AA	
4	781	Cable	1	Z3CA800-0000	
5	783	Warning tag PB	1	SWD9013AB	
6	784	Tag holder	1	E7SE003S9787	
7	1801	5 push button switch assembly	1	SWJ2220AC	
8	1481	Bar holder assembly	1	MR1DS1481	
9	481	Bar holder	1	MR1DS9481	
10	816	Cord chain stopper	1	E6LE010S9614	
11	817	Machine screw with spring washer	2	J1AP2-6001212	For cord chain stopper
12	482	Socket bolt with spring washer	2	J1BG1-1002828	For bar holder
13	1771	Power supply cable assembly	1	ZBZC12AJ1000	
14	351	Cable packing	1	ECP6914AA	
15	1724	Cable support 14 assembly	1	E4YS005-2822	230V, 400V Class
16	741	Name plate G	1	E6LE010S9806	
17	771	Cable	1	Z2CU402-0000	
18	1641	Cable hanger 14 assembly	n	E6AX003S1527	
19	1491	Cable support bar complete set	1	MR1DS1491	For power supply cable
20	491	Cable support bar	1	MR1DS9491	
21	492	Cable support arm	1	MR1DS9492	
22	1493	Wire guide assembly	1	MR1DS1493	
23	501	Support bar holder (plate)	1	MR1DS9501	
24	505	Bolt	2	J1BA2-0803030	For support bar holder (plate)
25	506	Spring lock washer	2	J1WS012-20080	For support bar holder (plate)
34	502	Bolt	1	J1BA2-0802525	
35	503	Spring lock washer	1	J1WS012-20080	
36	504	Nut	1	J1NA002-20080	
26	511	Cable hanger pusher	1	MR1DS9511	For T-type hanger (Beam 75mm)
	512	Cable hanger pusher	1	MR1DS9512	For T-type hanger (Beam 100-150mm)
27	516	Socket bolt	2	J1BG1-1002828	For cable hanger pusher
28	1791	Trolley cable assembly	1	MR2DS1791	
29	341	Holder A	2	ECP5924AA	
30	342	Holder B	1	ECP5924AB	
31	343	Packing	1	ECP5924AC	
32	351	Cable packing	2	ECP6912AA	
33	791	Cable	1	Z2CU401-0000	

WARRANTY

KITO Corporation (“KITO”) extends the following warranty to the original purchaser (“Purchaser”) of new products manufactured by KITO (KITO’s Products).

- 1) KITO warrants that KITO's Products, when shipped, shall be free from defects in workmanship and/or materials under normal use and service and KITO shall, at the election of KITO, repair or replace free of charge any parts or items which are proven to have said defects, provided that all claims for defects under this warranty shall be made in writing immediately upon discovery and, if there is anything within a warranty period stated by your dealer from whom you purchased the products from the date of purchase of KITO's Products by Purchaser and provided, further, that defective parts or items shall be kept for examination by KITO or its authorized agents or returned to KITO's factory or authorized service center upon request by KITO.
- 2) KITO does not warrant components of products provided by other manufacturers. However to the extent possible, KITO will assign to Purchaser applicable warranties of such other manufacturers.
- 3) Except for the repair or replacement mentioned in (1) above which is KITO's sole liability and purchaser's exclusive remedy under this warranty, KITO shall not be responsible for any other claims arising out of the purchase and use of KITO's Products, regardless of whether Purchaser's claims are based on breach of contract, tort or other theories, including claims for any damages whether direct, incidental or consequential.
- 4) This warranty is conditional upon the installation, maintenance and use of KITO's Products pursuant to the product manuals prepared in accordance with content instructions by KITO. This warranty shall not apply to KITO's Products which have been subject to negligence, misuse, abuse, misapplication or any improper use or combination or improper fittings, alignment or maintenance.
- 5) KITO shall not be responsible for any loss or damage caused by transportation, prolonged or improper storage or normal wear and tear of KITO's Products for loss of operating time.
- 6) This warranty shall not apply to KITO's Products which have been fitted with or repaired with parts, components or items not supplied or approved by KITO or which have been modified or altered.

THIS WARRANTY IS IN LIEU OF ALL OTHER WARRANTIES. EXPRESS OR IMPLIED, INCLUDING BUT NOT LIMITED TO ANY WARRANTY OF MERCHANTABILITY OR OF FITNESS FOR A PARTICULAR PURPOSE.

This warranty is not applicable in Australia. Please refer to your local supplier for warranty details when this product is purchased in Australia.

KITO

URL. <http://www.kito.com>