

---

## MAINTENANCE MANUAL for Model LX1B

---

### Table of Contents

1. GENERAL .....	2
2. DISASSEMBLY, ASSEMBLY AND ADJUSTMENT .....	2
3. COMPONENTS .....	3
4. HOIST DISASSEMBLY .....	4
5. HOIST ASSEMBLY .....	4
6. PREOPERATIONAL CHECKS.....	14

## 1. General

Improper maintenance may result in death or serious injuries. Ensure to have only trained or competent people maintain the hoist, or contact your dealer.

### **CAUTION**

- Do **NOT** lubricate the friction plate of the mechanical brake.
- Always ensure that the load chain, the chain pin, the top pin, the hook necks, the hook latches and the select lever are well oiled. Refer to Figure 1-1.

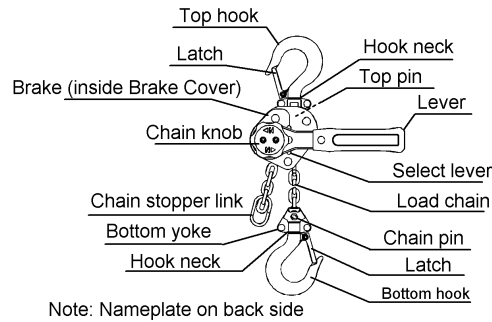

**Figure 1-1 Schematics**

- Do **NOT** store the hoist under a load.
- Remove any dirt or water on the hoist.
- Store the hoist in a dry and clean area.
- If any irregularity of the hoist is found after operation, perform all inspections given in the Owner's Manual and this manual's Item No.6.

## 2. Disassembly, Assembly and Adjustment

### **CAUTION**

- Perform proper maintenance in accordance with this manual.
- The friction plates are dry ones. Do **NOT** lubricate them.
- Do **NOT** extend the load chain, i.e. add extra links.
- Remove old grease and rust preventive oil from the disassembled components.
- Replace components with KITO authorized parts.
- For reassembly, apply new grease or rust preventive oil and replace a split pin.

Note: The following symbols in this manual indicate the recommended lubricants.

G1: Moly Speed Grease No. 2 (SUMICO LUBRICANT)

G2: JIS K2246 general class 2, No.1 rust preventive oil (Antirust P-210, NIPPON OIL)

G3: JIS K2220 general class 1, No.2 grease (Cup Grease 1-2, NIPPON OIL)

### 2.1. Tools

The size (mm) of hex keys to disassemble or reassemble the hoist as follows:

Product Code	Chain Knob	Bottom Yoke	Hook Latch	Brake Cover
LX003	3	3	3	4
LX005	3	N/A	3	4

### 3. Components

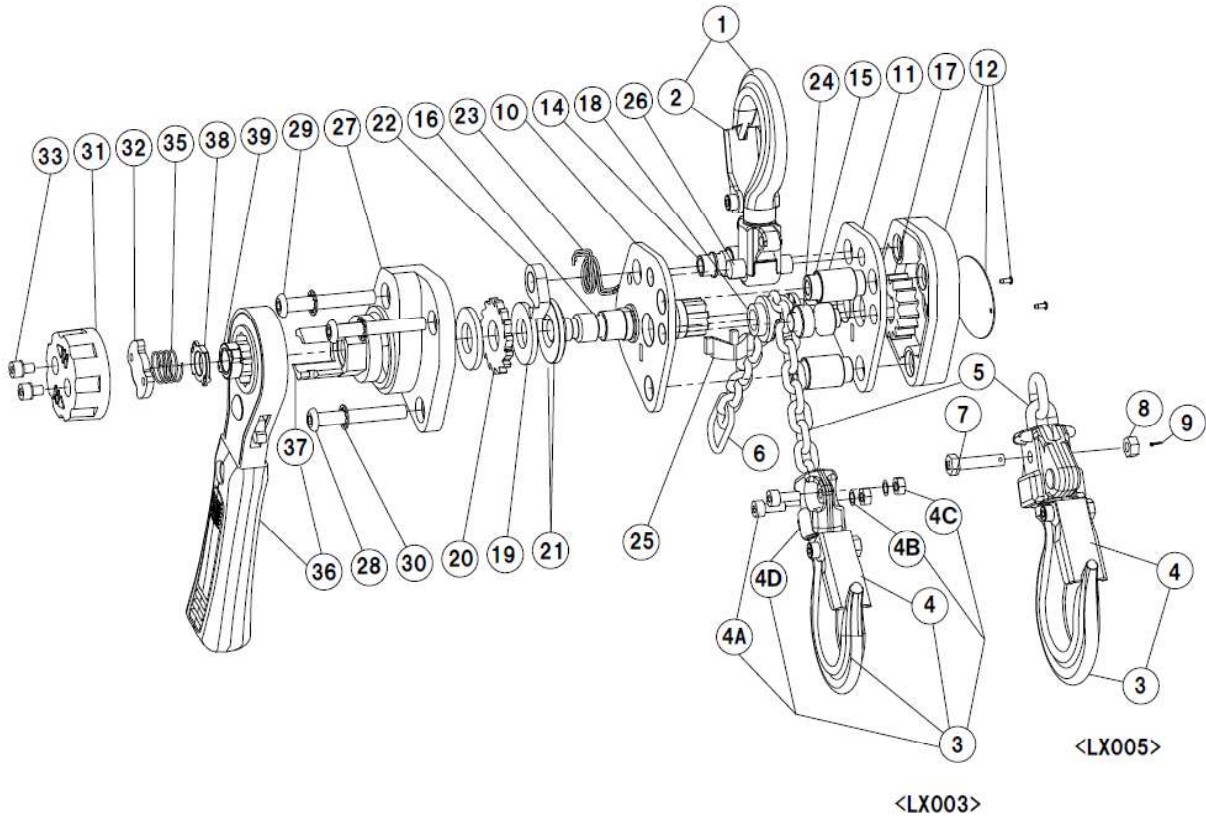

Figure No.	Part No.	Part Name	Parts per Hoist	Figure No.	Part No.	Part Name	Parts per Hoist
1	1001	Top Hook Set	1	17	114	Load Gear	1
2	1071	Latch Assembly	1	18	116	Load Sheave	1
3	1011	Bottom Hook Set for 1 m lift	1	19	151	Friction Plate	2
	1012	Bottom Hook Set for 2 m lift	1	20	152	Ratchet Disc	1
	1013	Bottom Hook Set for 3 m lift	1	21	153	Friction Disc	1
	1014	Bottom Hook Set for 4 m lift	1	22	155	Pawl	1
	1021	Bottom Hook Set	1	23	158	Pawl Spring Assembly	1
4	1071	Latch Assembly	1	24	161	Guide Roller	1
4A	81	Socket Head Cap Screw	2	25	162	Stripper	1
4B	83	Spring Lock Washer	2	26	163	Top Pin	1
4C	82	Hex Nut	2	27	172	Brake Cover	1
4D	31	Bottom Yoke	2	28	173	Button Head Socket Screw for LX003	2
					174	Button Head Socket Screw for LX005	2
5	841	Load Chain	1	29	174	Button Head Socket Screw	1
6	45	Chain Stopper Link	1	30	175	Internal Tooth Lock Washer	3
7	41	Chain Pin	1	31	201	Chain Knob	1
8	49	Slotted Nut	1	32	202	Lever Clamping Plate	1
9	42	Split Pin	1	33	206	Socket Screw with Conical Lock Washer	2
10	101	Frame A	1	35	205	Free Chain Spring	1
11	102	Frame B	1	36	4211	Lever Assembly	1
12	103	Gear Case	1		37	160	Female Thread
14	105	Stud B	1	38	209	Free Chain Plate	1
15	104	Stud A	2	39	203	Cam Guide	1
16	111	Pinion	1				

**Note:**

- Although the bottom hook set for LX003 can be disassembled, the set is supplied with the load chain in assembly.
- After replacing the nameplate, copy the original LOT and SERIAL NO. onto it.
- The detachable female thread is supplied with the lever.

## 4. Hoist Disassembly

Proceed as follows:

### 4.1. Free chain knob & Lever

- 1) After removal of (33) Socket Head Screw with Conical Lock Washer and (31) Chain Knob, turn (32) Lever Clamping Plate counterclockwise to detach the plate from the slot of (37) Female Thread, and remove the plate and (35) Free Chain Spring.
- 2) Remove (38) Free Chain Plate and (39) Cam Guide from (16) Pinion.
- 3) Set the select lever (refer to Figure 1-1) on (36) Lever Assembly to “DN.”
- 4) By turning (36) Lever Assembly counterclockwise approximately two times with the no-load side of (5) Load Chain pulled lightly, the assembly is removed from the hoist’s body.

### 4.2. Brake

- 1) Remove (28) and (29) Button Head Socket Screw fixing (27) Brake Cover, and remove the cover.
- 2) With (22) Pawl and (20) Ratchet Disc disengaged, remove first (19) Friction Plate (outer) from (16) Pinion, and then (20) Ratchet Disc followed by (19) Friction Plate (inner) and finally (21) Friction Disc.
- 3) Remove (22) Pawl and (23) Pawl Spring from (14) Stud B.

### 4.3. Load Sheave & Gear case

- 1) Remove (10) Frame A, two of (15) Stud A, (14) Stud B, (26) Top Pin, (1) Top Hook Set, (24) Guide Roller, (16) Pinion, (25) Stripper, (5) Load Chain and (18) Load Sheave in this order.
- 2) Remove (11) Frame B and (17) Load Gear.

## 5. Hoist Assembly



- Inspect and replace any worn or damaged parts according to the inspection manual.
- Secure all nuts and bolts firmly with the specific torque.
- Also secure all new split pins.

### 5.1. Gear Case & Load Sheave

Refer to Figure 5-1 and proceed as follows:

- 1) Apply (G3) grease to the cogs of (17) Load Gear.
- 2) Place (12) Gear Case on a flat surface and set (17) Load Gear to the center of the circular risen part inside the gear case as shown in Figure 5-1.
- 3) Align the holes and rims of (12) Gear Case and (11) Frame B.

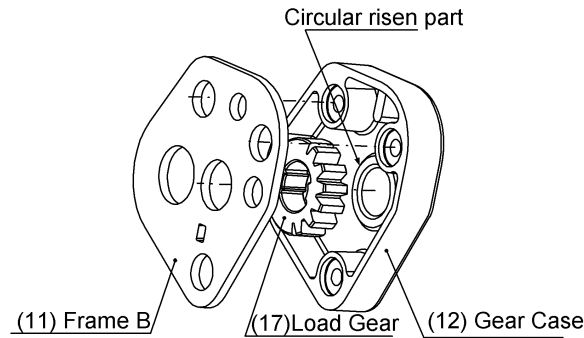

**Figure 5-1 Load Gear and Frame B Attachment to Gear Case**

- 4) Apply (G1) grease to the parts of (18) Load Sheave contacting the holes of (11) Frame B as shown in Figure 5-2

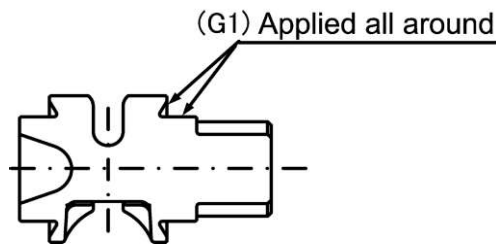

**Figure 5-2 Applying Grease to Load Sheave**

- 5) Align (18) Load Sheave with (17) Load gear as viewed from the hole of (11) Frame B, and insert the end of the sheave as shown in Figure 5-3.

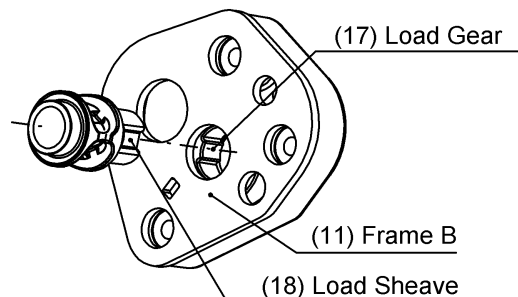

**Figure 5-3 Load Sheave Attachment to Frame B**

## 5.2. Studs & Load Chain

- 1) Insert (15, 14) Studs A and B into their respective bases of (12) Gear Case as shown in Figure 5-4.

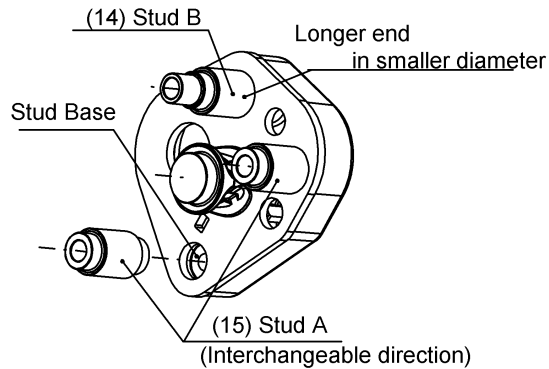

**Figure 5-4 Stud Attachment**

- 2) Fasten (5) Load Chain to the bottom hook assembly as shown in "5.8 Hook & Load Chain."
- 3) With (6) Chain Stopper Link in correct direction, no twisted links on (5) Load Chain, and the chain welded part directed outward, set the chain onto (18) Load Sheave correctly as shown in Figure 5-5.

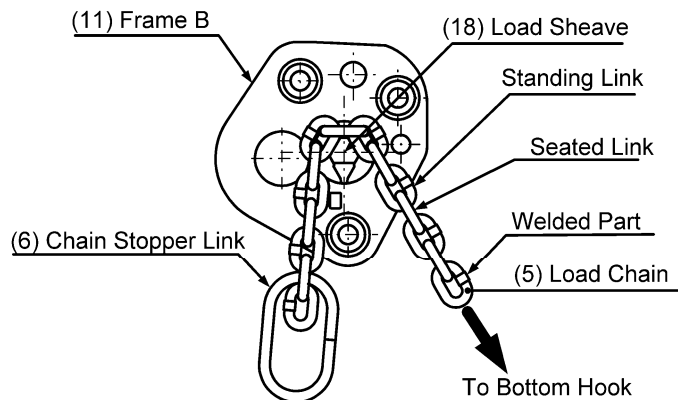

**Figure 5-5 Load Chain Reeving Direction**

- 4) Apply (G1) grease to the shaft of (24) Guide Roller contacting the hole of (11) Frame B as shown in Figure 5-6.

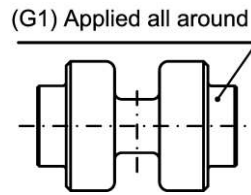

**Figure 5-6 Applying Grease to Guide Roller**

- 5) Align a seated link with the slot of (24) Guide Roller and insert the roller into the hole of (11) Frame B as shown in Figure 5-7.

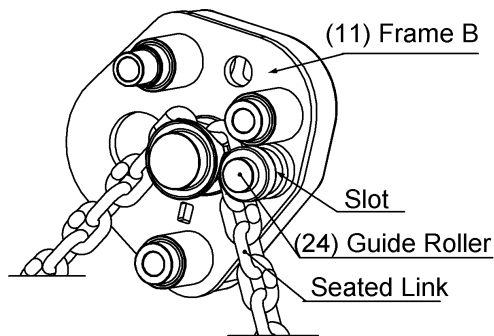

**Figure 5-7 Guide Roller Attachment to Frame A**

### 5.3. Pinion & Stripper

- 1) Apply (G3) grease to the cogs of (16) Pinion and (G1) grease to the part of the pinion contacting the hole of (11) Frame B as shown in Figure 5-8.

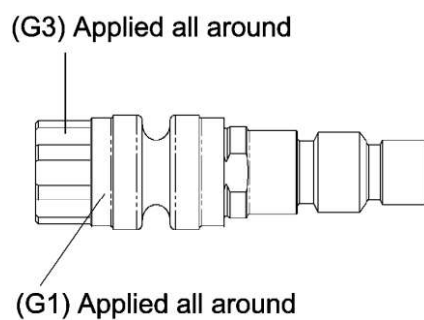

**Figure 5-8 Applying Grease to Pinion**

- 2) Align the pinion with (17) Load Gear as viewed from the hole of Frame B and insert the pinion into the hole as shown in Figure 5-9.

Note: For proper assembly of (16) Pinion and (5) Load Chain, place the pinion with a seated link of the chain facing the slot of it.

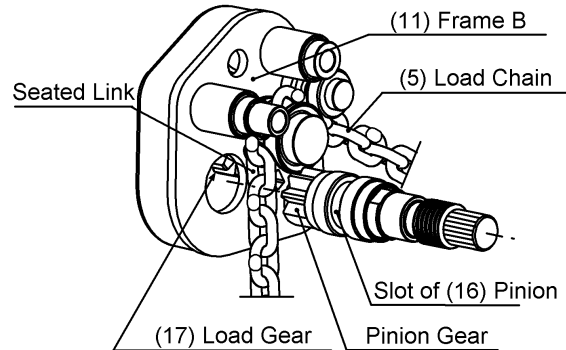

**Figure 5-9 Pinion Attachment to Frame B**

- 3) Align the boss with the center of (25) Stripper with a pocket of (18) Load Sheave and insert the end of the stripper into the square hole in (11) Frame B. Refer to Figure 5-10.

Note: For proper assembly of (25) Stripper and (5) Load Chain, place the stripper with a seated link of the chain facing the stripper.

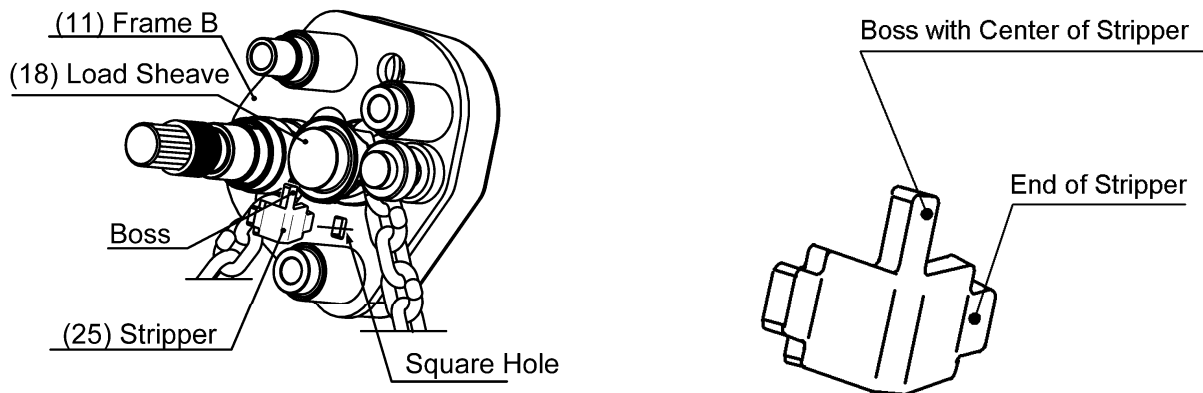

**Figure 5-10 Stripper Attachment to Frame B**



#### 5.4. Frame A & Hook

- 1) Apply (G1) grease to the following parts:

Refer to Figure 5-11.

- The hole rim for (16) Pinion in (10) Frame A or the equivalent section on the pinion
  - The hole rim for (18) Load Sheave in (10) Frame A or the equivalent section on the sheave
  - The hole rim for (24) Guide Roller in (10) Frame A or the equivalent section on the roller
- 2) Align Frame A with (16) Pinion, (18) Load Sheave, (24) Guide Roller, (15) Stud A, (14) Stud B and (25) Stripper, and attach them as shown in Figure 5-11.

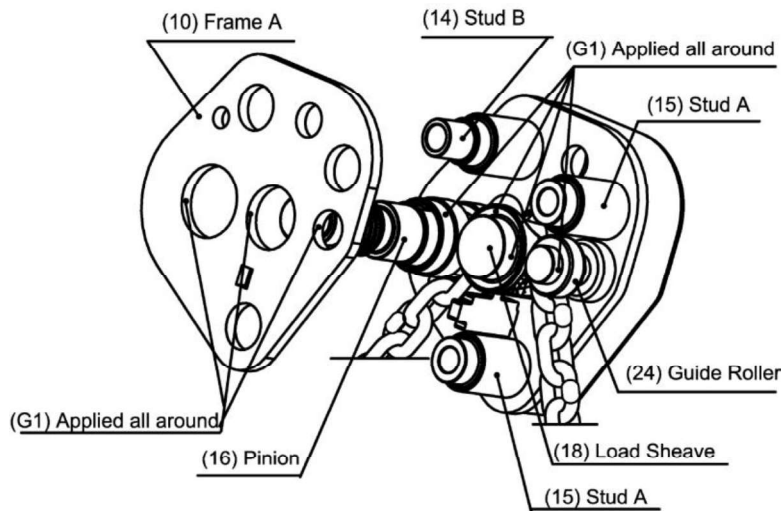

**Figure 5-11 Frame A Attachment**

- 3) Attach (1) Top Hook Set between (10, 11) Frame A and B and insert (26) Top Pin into the hole for the hook in Frame A. Refer to Figure 5-13.

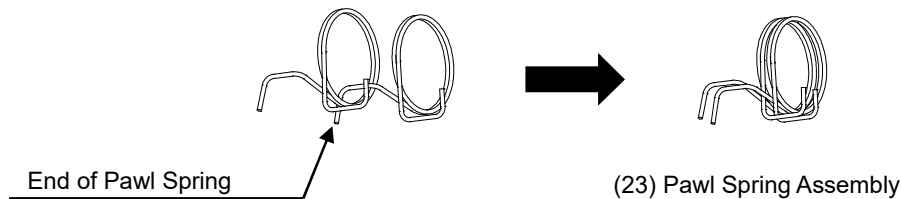

**Figure 5-12 Pawl Spring Assembly**

- 4) Put the end of one pawl spring through the coiled part of the other pawl spring and fit each other into (23) Pawl Spring Assembly as shown in Figure 5-12.

### 5.5. Pawl & Brake

Refer to Figure 5-13 and proceed as follows:

- 1) Apply (G2) grease to (14) Stud B and (23) Pawl Spring Assembly.
- 2) Put the end of (23) Pawl Spring Assembly into the small hole in (10) Frame A and place the spring assembly around the bottom of (14) Stud B.
- 3) Place (22) Pawl around (14) Stud B and hook the opposite end of (23) Pawl Spring Assembly around the Pawl.
- 4) While directing the tip of the pawl outward by turning (22) Pawl counterclockwise, attach (21) Friction Disc (as shown in Figure 5-14) and (19) Friction Plate (inner) to (16) Pinion.

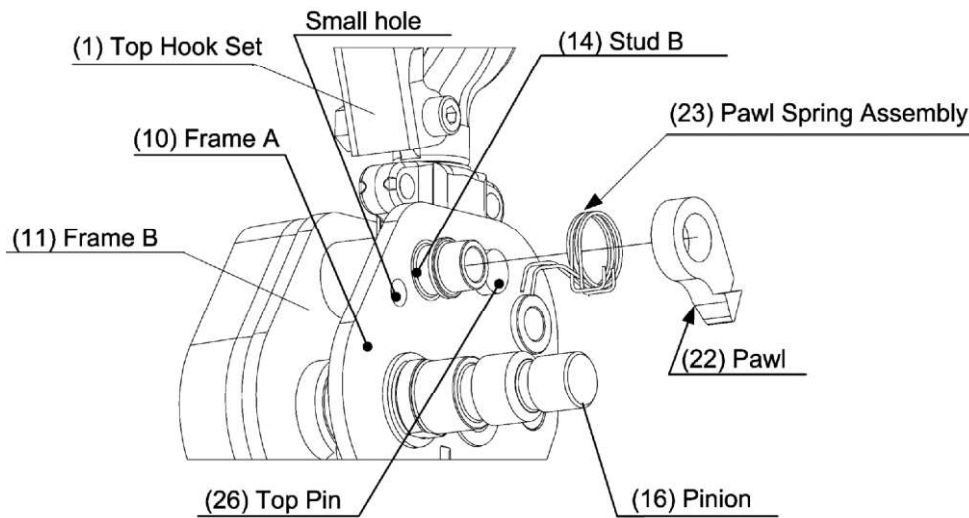

**Figure 5-13 Pawl and Pawl Spring Attachments**

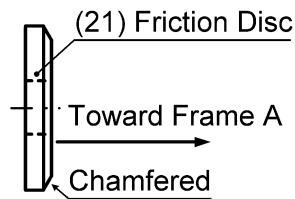

**Figure 5-14 Friction Disc**

Refer to Figure 5-15 and proceed as follows:

- 5) Apply (G1) grease lightly to the inner circle of (20) Ratchet Disc.
- 6) Attach (20) Ratchet Disc and (19) Friction Plate (outer) to the pinion while directing the tip of the pawl outward by turning (22) Pawl counterclockwise.
- 7) Ensure that (22) Pawl and (20) Ratchet contact properly and turn smoothly.

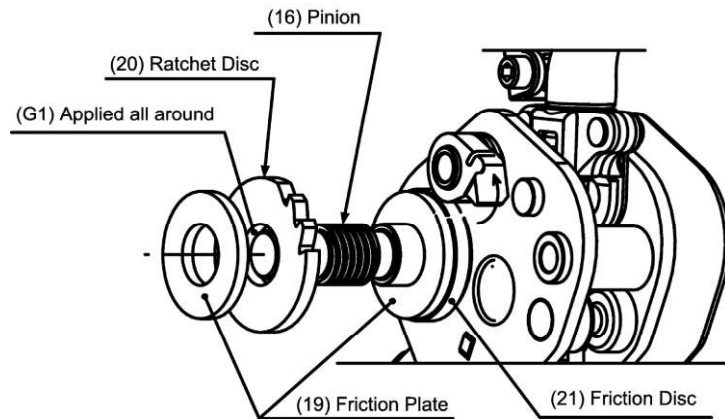
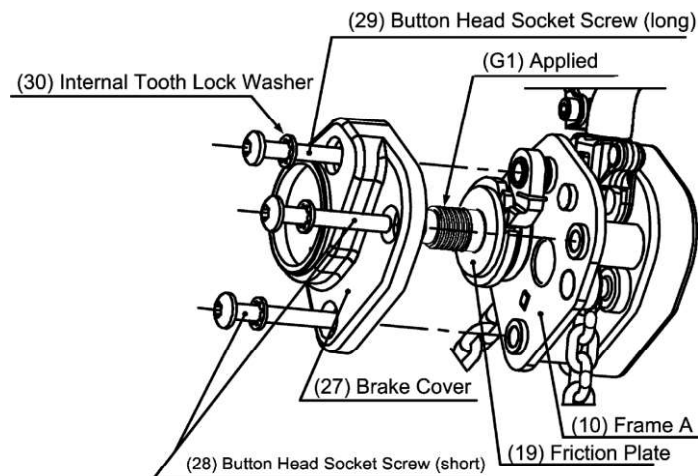

**Figure 5-15 Friction Plates and Ratchet Disc Attachments**

#### 5.6. Brake Cover

Refer to Figure 5-16 and proceed as follows:

- 1) Avoid getting any (G1) grease on the friction surfaces while applying the grease to the multiple screws and serration on (16) Pinion.
- 2) Align (27) Brake Cover with (10) Frame A, the studs A and B, and attach them.
- 3) Set (30) Internal Tooth Lock Washer to (28, 29) Button Head Socket Screw, and insert the screw into (27) Brake Cover and secure the 3 screws of (28) and (29) in this order with the torque between 8.8 Nm and 9.8 Nm.



**Figure 5-16 Friction Plates and Ratchet Disc Attachments**

## 5.7. Lever & Chain Knob

**CAUTION** Clean the friction surface of (37) Lever Assembly.

**WARNING** Do **NOT** apply oil to the friction surface of (37) Lever Assembly.

Refer to Figures 5-17 and proceed as follows:

- 1) Attach the thread of (36) Lever Assembly to (16) Pinion and set the select lever to "UP" and turn the lever clockwise with the hook-side chain pulled firmly until the hoist makes clicking sounds.

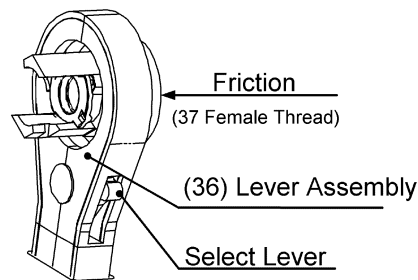

**Figure 5-17 Friction Surface of Lever Assembly**

- 2) As shown in Figure 5-18, set (39) Cam Guide with its boss upward around (16) Pinion as the boss is aligned between the left end and the right end.

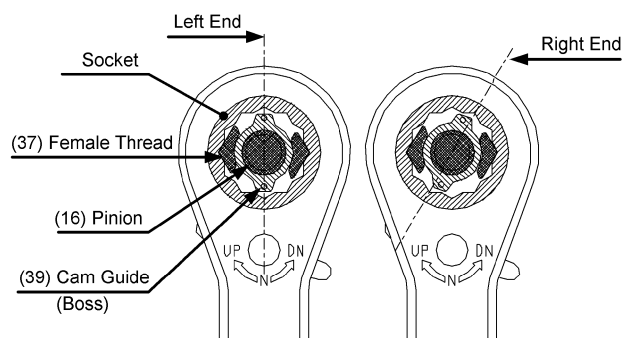

**Figure 5-18 Cam Guide Attachments**

Refer to Figures 5-19 and proceed as follows:

- 3) Attach (38) Free Chain Plate with its boss downward around the pinion, and then apply (G2) rust preventive oil to (35) Free Chain Spring and place it on the plate, and next set (32) Lever Clamping Plate into the slot of (37) Female Thread by (a) placing (32) Lever Clamping Plate and (b) turning the clamping plate clockwise.

Note: Do not assemble the free chain spring for Model LX1A identified with the both spring ends filed more than a half circle.

- 4) Align the screw holes of (31) Chain Knob to those of (32) Lever Clamping Plate, and secure them with (33) Socket Head Screw with Conical Lock Washer at the torque between 5.0 Nm and 5.5 Nm.

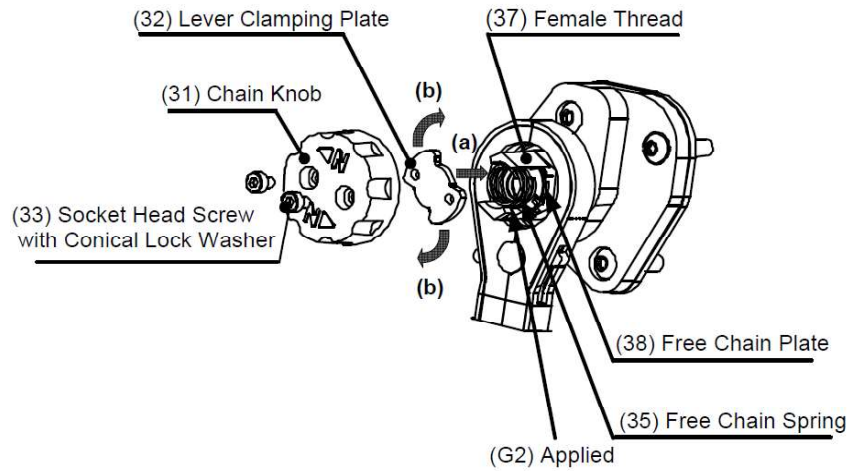

**Figure 5-19 Friction Plates and Ratchet Disc Attachments**

## 5.8. Hook & Load Chain

### 5.8.1. LX003

Refer to Figure 5-20 and proceed as follows:

- 1) First, place (5) Load Chain and (3) Bottom Hook on (4D) Bottom Yoke (one) as shown in the following picture, and secondly attach (4D) Bottom Yoke (the other) to them, and then secure them with (4A) Socket Head Cap Screw, (4C) Hex Nut and (4B) Spring Lock Washer at the torque between 2.1 Nm and 3.1 Nm.
- 2) Apply the following fasteners to the screw of (4A) Socket Head Cap Screw.  
Recommended fasteners: ThreeBond 1401, Loctite 241/242

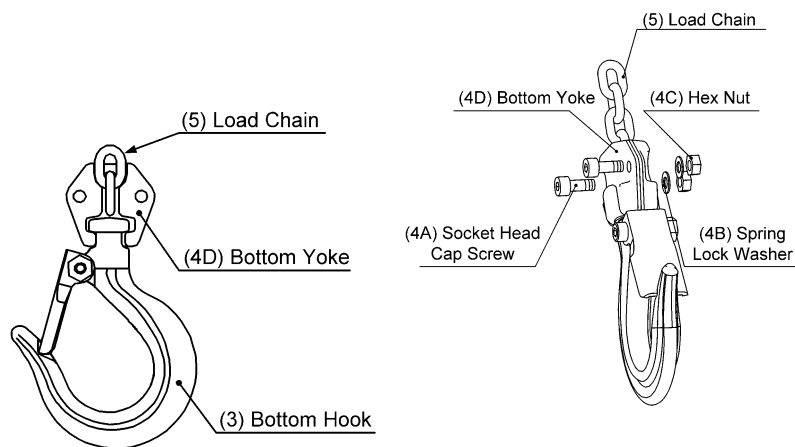
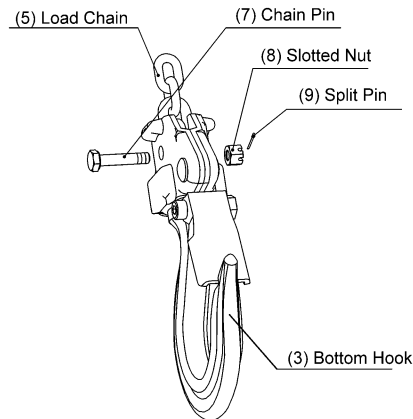

**Figure 5-20 LX003 Hook & Load Chain Attachments**

### 5.8.2. LX005

Refer to Figure 5-21 and proceed as follows:

- 1) First, insert (5) Load Chain into (3) Bottom Hook Set, and secondly insert (7) Chain Pin through the bottom yoke, and next tighten the pin with (8) Slotted Nut, and then secure them with (9) Split Pin bent.



**Figure 5-21 LX005 Hook & Load Chain Attachments**

## 6. Preoperational Checks

**⚠ CAUTION** After assembly, ensure to perform the preoperational checks with the following points before reuse.

- 1) Check defects in appearance, any parts left to be installed.
- 2) Perform lifting and lowering operations under no load with the load-side chain slightly pulled and check the following items.
  - Should be free of irregular clicking sounds in lifting or abnormal sounds
  - Should be free of difficult pull to lift
  - Should be free of brake slipping
- 3) Set the select lever to “N” and with the no-load-side chain pulled lightly, turn (31) Chain Knob counterclockwise fully into the free chaining mode, and then check free chaining operation.
- 4) Ensure that the hoist operates properly under no load conditions before checking the hoist under a load.