

Supplementary Manual

ER2 Series Electric Chain Hoist (7.5t to 20t)

Owner's Manual

Suspended with

Hook : ER2

Motorized Trolley : ER2M

Manual Trolley : ER2SP/ER2SG

To Customer

This manual contains specific information related to large capacity models. Before use, please read and comply with all the contents of the "ER2 Series Electric Chain Hoist (125kg to 5t) Owner's Manual" (separate publication) as well as this manual to ensure proper use of the products.

Table of Contents

Safety Precautions	2
Product Specification and Operational Environment	3
• Standard Specifications	3
• Operational Environment	5
Nameplate and Product Code	6
• Nameplate of Electric Chain Hoist	6
• Nameplate of Motorized Trolley	7
• Nameplate of Manual Trolley	7
• Product Code of Large Capacity	7
Checks on Unpacking	8
• Checking Chain Stamps	8
• Recording the Product No	8
• Recording the Initial Value	8
Assembling	9
• Installing a Chain Container	9
• Checking Power and Power Cable	13
• Connecting Cables	15
Regular inspection	20
• Daily Inspection	20
• Frequent Inspection	21
• Periodic Inspection	23
Appendix	27
Wiring Diagram	27

Safety Precautions

CAUTION



Mandatory

This owner's Manual provides specific information regarding the ER2 electric chain hoist (7.5t to 20t). Before operating the product, be sure to read and comply with all the contents of both this Manual and the ER2 Series Electric Chain Hoist (125kg to 5t) Owner's Manual to operate the product correctly.

Product Specifications and Operational Environment

The operational environment of the electric chain hoist and motorized trolley is as follows:

■ Standard Specifications

- Short-time rating : ER2 (100% of rated load) - 60 minutes,
MR2 (100% of rated load) - 30 minutes
- Intermittent rating : ER2 (63% of rated load) - 60% ED, MR2 (63% of rated load) - 40% ED
- Hoist classification * : ISO-M4,FEM-2m,ASME-H4
- Protection : Hoist IP55,Push Button Switch IP65
- Push button control : 3-push button control for hook or manual trolley suspension, / 5 or 7-push button control for motorized trolley suspension
- Lift : 3m (standard)
- Power supply method : Cabtyre cable
- Color : KITO Yellow (Equivalent to Munsell 7.2YR6.5/14.5)
- Braking capacity : 150% or more
- Applicable rail type : I beam, H beam
- Applicable rail width : 150mm – 308mm
- Power supply cable : Standard length - 10m
- Voltage & motor :

Voltage category	Motor Insulation Class	Voltage range		Control Voltage
		50Hz	60Hz	
230V Class	B	220V	220V	24V (24V~27.8V)
		230V	230V	
400V Class	F	380V	380V	
		400V	440V	
		415V	—	
500V Class	B	500V	575V	
230/460V Class	B	/	208-230V	110V (110V~121V)
			415-460V	

* For more information about the operating conditions and environment, refer to the ER2 Series Electric Chain Hoist (125kg to 5t) Owner's Manual, and for the standard dimensions refer to the appendixes in this manual.

NOTE

- Operate the electric chain hoist at the rated voltage.
- Do not use the electric chain hoist beyond the short time and intermittent ratings.

* Hoist classification

Capacity (t)	Code	ISO	ASME	FEM
7.5	ER2-075S	M4	H4	1Am
10	ER2-100L			
	ER2-100S			
	ER2-150S			
20	ER2-200S			

• **ISO**

ISO 4301 specifies the total operating hour (service life) of gears and bearings according to the loading status. For example, the total operating hour (service life) of the mechanism for M5 constantly subjected to the rated load is 1,600 hours. The total operating hour reaches 6,300 hours under a medium load.

Loading status	Total operating hour h				
	800	1600	3200	6300	12500
Light				M4	M5
Medium			M4	M5	
Heavy		M4	M5		
Ultra heavy	M4	M5			

***Rate of loading**

- Light : A case where the capacity is rarely applied. Usually the hoist is used with a light load.
- Medium : A case where the capacity is applied considerably frequently. Usually the hoist is used with a medium load.
- Heavy : A case where the capacity is applied considerably frequently. Usually the hoist is used with a heavy load.
- Ultra heavy: A case where the capacity is applied constantly.

• **ASME HST**

Hoist duty class	Typical areas of application	Operation time ratings at K=0.65			
		Uniformly distributed work periods		Infrequent work periods	
		Max. on time, min / hr	Max. No. starts / hr	Max. on time from cold start, min	Max. No. of starts
H2	Light machine shop fabricating, service, and maintenance; loads and utilization randomly distributed; capacities infrequently handled.	7.6 (12.5%)	75	15	100
H3	General machine shop fabricating, assembly, storage, and warehousing; loads and utilization randomly distributed.	15 (25%)	150	30	200
H4	High volume handling in steel warehouses, machine shops, fabricating plants and mills, and foundries; manual or automatic cycling operations in heat treating and plating; loads at or near capacity frequently handled.	30 (50%)	300	30	300

- The grade symbols are identical to those of ASME HST-1M. (Performance standard for Electric Chain Hoist)

• **FEM**

Relation between ISO-and FEM-Denominations

1 Dm	1 Cm	1 Bm	1 Am	2 m	3 m	4 m	5 m
M 1	M 2	M 3	M 4	M 5	M 6	M 7	M 8

Load spectrum	Cubic mean value	Class of operation time									
		V0.06	V0.02	V0.25	V0.5	V1	V2	V3	V4	V5	
		T0	T1	T2	T3	T4	T5	T6	T7	T8	
		Average operation time per day in hours									
		≤0.12	≤0.25	≤0.5	≤1	≤2	≤4	≤8	≤16	>16	
1 L1	K≤0.50	-	-	1 Dm	1 Cm	1 Bm	1 Am	2 m	3 m	4 m	
2 L2	0.50<K≤0.63	-	1 Dm	1 Cm	1 Bm	1 Am	2 m	3 m	4 m	5 m	
3 L3	0.63<K≤0.80	1 Dm	1 Cm	1 Bm	1 Am	2 m	3 m	4 m	5 m	-	
4 L4	0.80<K≤1.00	1 Cm	1 Bm	1 Am	2 m	3 m	4 m	5 m	-	-	

Class of operating time	Average operating time per day (in hours)	Calculated total operating time (in hours)
V0.06 T0	≤0.12	200
V0.12 T1	≤0.25	400
V0.25 T2	≤0.5	800
V0.5 T3	≤1	1,600
V1 T4	≤2	3,200
V2 T5	≤4	6,300
V3 T6	≤8	12,500
V4 T7	≤16	25,000
V5 T8	>16	50,000

- The grade symbols are identical to those of FEM 9.511. (Rules for Design of Serial Lifting Equipment: Classification of Mechanisms)

■ Operational Environment

Ambient temperature	: -20°C to +40°C
Slope of rail	: No slope of travelling rail (for the hoist with trolley)
Ambient humidity	: 85 % or less (no condensation)
Explosion-proof construction	: Not applicable to the work environment with explosive gases or explosive vapor
Environment to be avoided	: A place with organic solvent or volatile powder, and a place with a plenty of powder and dust of general substances
	: A place with considerable amount of acids and salts

NOTE

When installing the electric chain hoist outdoors or to the place where the hoist is exposed to direct rain, wind and snow, shelter the hoist under a roof to protect it from rain, wind and snow.

Nameplate and Product Code

■ Nameplate of Electric Chain Hoist

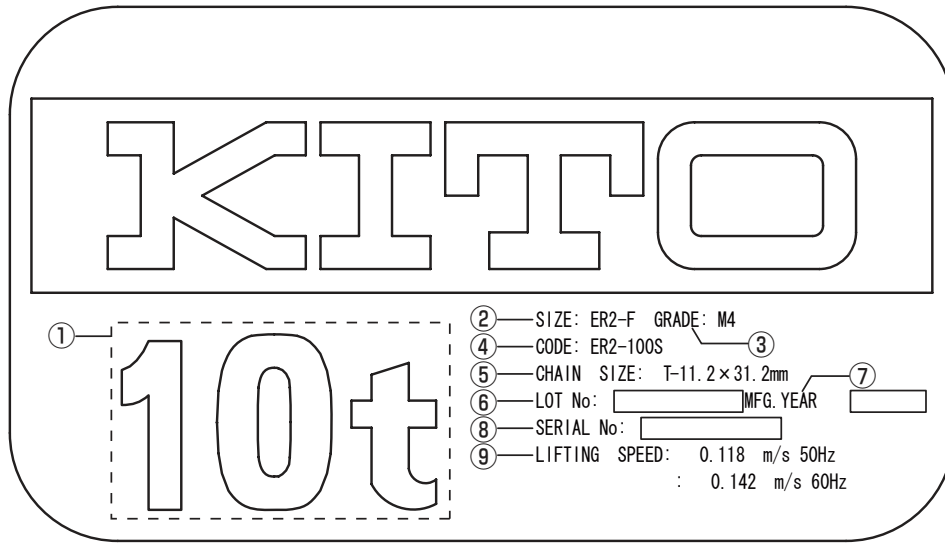

- | | |
|--|--|
| <p>1 <input type="text"/> Capacity Ex. 10t
The maximum mass of the load that can be imposed on the product. The mass of the hook is excluded.</p> <p>2 SIZE Body size Ex. Body size F, ER2-F
The size of the electric chain hoist body to support the load. Five models of B, C, D, E and F are provided.</p> <p>3 GRADE Ex. M4
The grade of an electric chain hoist specified by Japanese Industrial Standard JIS indicates degree of durability.</p> <p>4 CODE Product code Ex. ER2-100S
The code is denotations composed of product model, capacity, lifting speed.</p> | <p>5 CHAIN SIZE Load Chain size
Ex. T-11.2×31.2mm
The alphabet and the figures indicate the JIS grade, wire diameter and chain pitch respectively.</p> <p>6 LOT No.
Manufacture No. to identify the time of manufacture and a batch of production.</p> <p>7 MFG. YEAR Manufacture year</p> <p>8 SERIAL No.
Serial number to indicate the manufacturing sequence of the product.</p> <p>9 LIFTING SPEED</p> |
|--|--|

■ Nameplate of Motorized Trolley

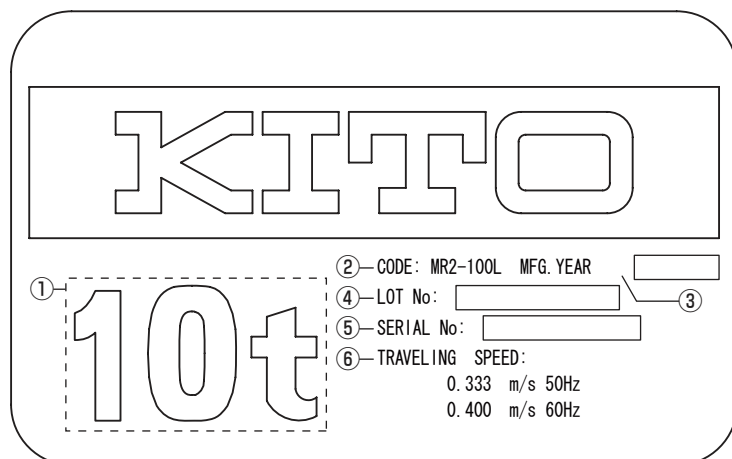

- 1 Capacity Ex. 10t
The maximum mass of the load that can be imposed on the product. The mass of the hook is excluded.
- 2 CODE ... Product code Ex. MR2-100L
The code is denotations composed of product model, capacity, lifting speed.
- 3 MFG. YEAR ... Manufacture year
- 4 LOT No.
Manufacture No. to identify the time of manufacture and the quantity of a production unit.
- 5 SERIAL No.
Serial number to indicate the manufacturing sequence of the product.
- 6 TRAVELING SPEED

■ Nameplate of Manual Trolley

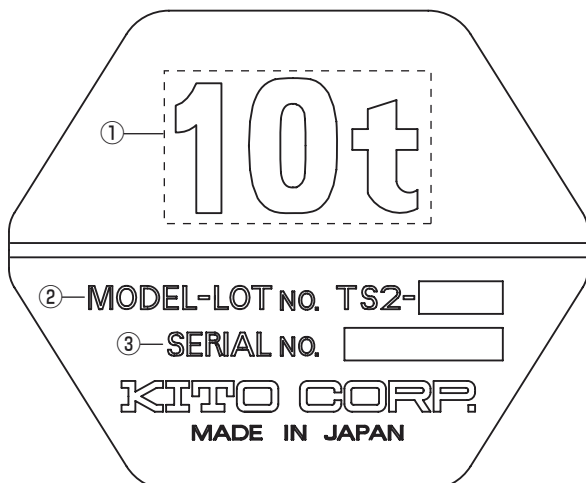

- 1 Capacity Ex. 10t
The maximum mass of the load that can be imposed on the product. The mass of the hook is excluded.
- 2 LOT No.
Manufacture No. to identify the time of manufacture and the quantity of a production unit.
- 3 SERIAL No.
Serial number to indicate the manufacturing sequence of the product.

■ Product code of large capacity

Capacity	Code				
	Electric chain hoist			Motorized trolley	Manual trolley
	Body size	Standard speed	Low speed	Low speed	(geared trolley)
7.5t	ER2-F	ER2-075S	-	MR2-075L	TSG075
10t		ER2-100S	ER2-100L	MR2-100L	TSG100
15t		ER2-150S	-	MR2-150L	TSG150
20t		ER2-200S	-	MR2-200L	TSG200

Checks on Unpacking

⚠ DANGER



Mandatory

After unpacking, confirm chain stamp, and make a record of serial number and an inspection as shown below.

■ Checking Chain Stamps

⚠ DANGER



Mandatory

• Be sure to check that the Load Chain is for the electric chain hoist ER2. The Load Chain of other models (such as model ES or ER) or for different capacity cannot be used.

Failure to use a proper chain may result in death or serious injury due to the drop of the lifted load.

The load chain identification stamp (RH-DAT) is indicated on at intervals of chain links. Make sure that the Load Chain is of a chain size (wire diameter) appropriate for ER2 referring to the table below.

Capacity	Load Chain : diameter (mm)	Stamp interval
7.5t	11.2	12 links
10t		
15t		
20t		

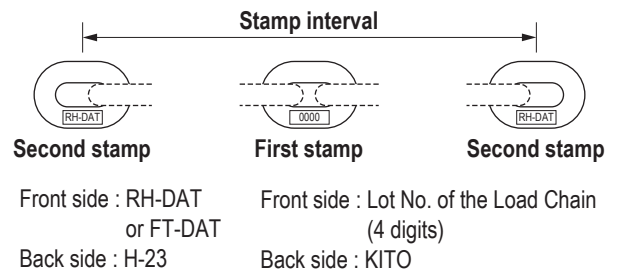

■ Recording the Product No.

- Fill in the table in the right with product's Lot No., Serial No. (described in the product nameplate), date of purchase and the name of the sales shop where you purchased the product.

* When requesting repair or ordering a hoist part, please inform us of these pieces of information together.

Item	Electric chain hoist	Motorized trolley	Manual trolley
Lot No.	ER2A-	MR2A-	TS2-
Serial No.			
Date of purchase			
Name of the sales shop			

■ Recording the Initial Value

- For later maintenance or inspection, at the time of unpacking, fill in the table in the right with the dimension "a" between embossed marks on the Bottom Hook, the width of the hook "b" and the thickness of the hook "c". (These values are used for checking. Please also record the value for the top hook of ER2 when your product is suspended with a hook.)

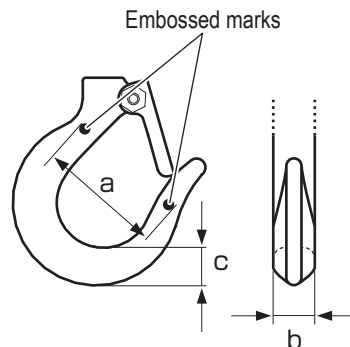

Initial dimensions

Top Hook (For ER2 only)	Dimension a	mm
	Dimension b	mm
	Dimension c	mm
Bottom Hook	Dimension a	mm
	Dimension b	mm
	Dimension c	mm

Assembling

DANGER



Prohibited

- Only qualified maintenance personnel or experts are allowed to assemble and disassemble the electric chain hoist.

Assembly or disassembly of the hoist by incompetent personnel may result in death or serious injury.

■ Installing a Chain Container

■ Preparation for Assembling

- To facilitate mounting the chain container, hang the hoist body.
- Check that the stopper and the cushion rubber are attached to the third link from the end of the no-load side chain (the side without the Bottom Hook).

■ Assembling

The two types of the Chain Container are provided: canvas and steel

This manual describes the method to combine the canvas Chain Container with the body of the electric chain hoist.

Refer to the separate "Mounting Manual of the Steel Chain Container" for the steel Chain Container.

DANGER



Mandatory

- The each type of Chain Container has the capacity to store the specific amount of the Load Chain. Use the Chain Container in correct capacity.

An chain overflow from the overstored container or a drop of container improperly installed on the hoist can cause quite dangerous situation, resulting in fatal or serious injury.

Failure to have the maintenance personnel install the Chain Container may cause fatal or serious injury.

Before installation of the container, please also check the container capacity of the hoist and lifting height as shown on the container.

CAUTION



Mandatory

- When storing the Load Chain into the Chain Container, put the end of no-load side chain first and then store the rest of the Load Chain in order.

Failure to comply with these instructions may causes bodily injury or loss of property.

● Chain Container Seal

A seal in the right to indicate the hoist capacity and the maximum lift is attached to the Chain Container. Be sure to check it before installation.

H1	CODE	LIFT MAX
	ER100S	6m
	ER075S,ER150S	4m
	ER100L,ER200S	3m

● 7.5t, 10t(L)

- 1) Install 2 container chains to the chain container with socket bolts, plain washers, and lever nuts.
- 2) Install the lug of the container on the chain guide A at the bottom of the hoist with the bolts and lever nuts.
- 3) Install 2 container chains to the container suspender with the socket bolts, plain washers and lever nuts.

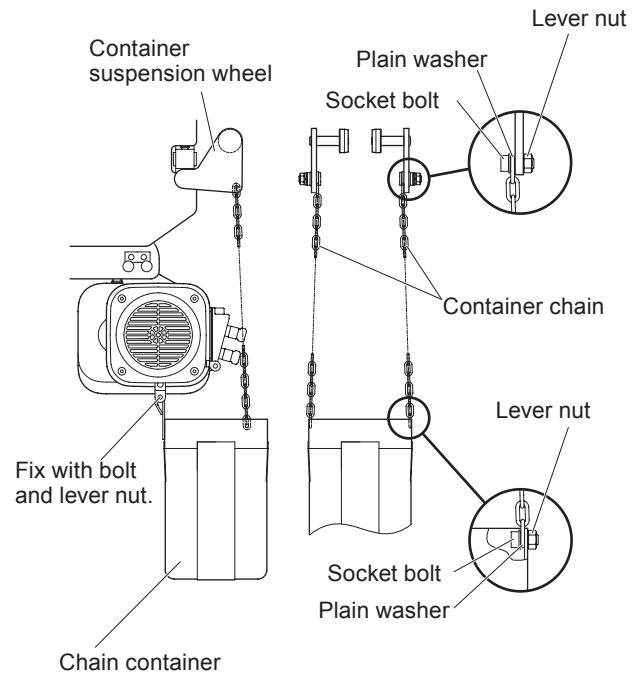

● 10t(S), 15t(S), 20t(S)

- 1) Install 2 container chains to the chain container with socket bolts, plain washers, and lever nuts.
- 2) Install the lug of the container on the chain guide A at the bottom of the hoist with the bolts and lever nuts.
- 3) Insert the socket bolt through a plate of the Connection yoke, both end links of container chains and the other plate and fasten them with plain washers and lever nuts.

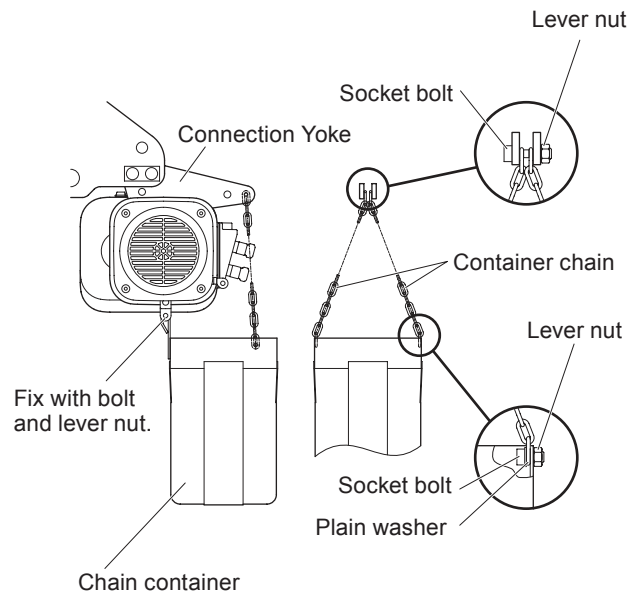

■ Checking rails used for the trolley, and adjusting the collar

Although the product is shipped in conjunction as far as the order of the hoist and trolley is made, it is necessary to adjust the collars to the width of your rail. When a rail width is specified upon order, the collars arrangement is made at shipment. However, if you change to a different rail width, make correct collar adjustments as explained in this section.

● Rail and wheel profile

In the conjunction with the motorized or manual trolley, the profile of the trolley wheel and the rail should meet. Check the profile of both the rail and the wheel.

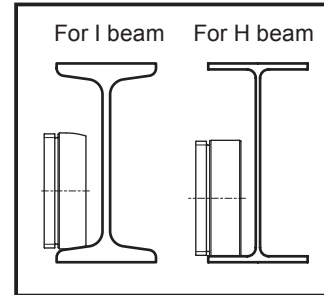

■ Rail spacer arrangement

Improper spacer arrangement could result in missing, irregular running or dropping. Make correct adjustments of the trolley spacers to the rail width as shown in the following the table.

● Motorized Trolley

		Number of Adjusting Spacers																																					
W (mm)	Beam flange width (mm)	149	153	155	160	163	170	175	178	180	184	200	203	215	220	229	232	250	254	257	260	264	267	279	283	286	289	295	298	300	302	305							
	Parts																																						
7.5 to 20	Thin spacer	Inner	1+1	1+2	1+2	2+3	3+3	4+4	1+1	1+2	2+2	2+3	1+1	1+2	3+3	4+4	1+1	1+2	4+4	1+1	1+2	2+2	2+3	3+3	1+1	1+2	2+2	2+3	3+4	1+1	1+2	2+2	2+3	3+4	4+0	4+0	4+1	5+1	
		Outer	6	5	5	3	2	0	6	5	4	3	6	5	2	0	6	5	0	6	5	4	3	2	6	5	4	3	1	4	4	3	2						
	Thick spacer	Inner	1+1	1+1	1+1	1+1	1+1	2+2	2+2	2+2	2+2	3+3	3+3	3+3	3+3	1+1	1+1	1+1	2+2	2+2	2+2	2+2	2+2	3+3	3+3	3+3	3+3	3+3	3+3	3+4	3+4	3+4	3+4	3+4	3+4	3+4	3+4	3+4	3+4
		Outer	4	4	4	4	4	4	2	2	2	2	0	0	0	0	5	5	5	3	3	3	3	3	3	1	1	1	1	1	0	0	0	0	0	0	0	0	0
	Fixing spacer	Inner	-	-	-	-	-	-	-	-	-	-	-	-	-	-	-	-	-	-	-	-	-	-	-	-	-	-	-	-	-	-	-	-	-	-	-	-	-
			Outer	-	-	-	-	-	-	-	-	-	-	-	-	-	-	-	-	-	-	-	-	-	-	-	-	-	-	-	-	-	-	-	-	-	-	-	-

Remarks: (1) Take note the numbers on spacers of inner side as follows.

Example 0+1

0 : Number on side plate S

1 : Number on side plate G

(2) Adjustment of trolley width :

Adjust the dimensions by appropriately increasing or decreasing the number of inner or outer adjusting spacers, without strictly adhering to the number of adjusting spacers shown in the above table.

(3) Spacers arrangement example.

Number of Adjusting Spacers

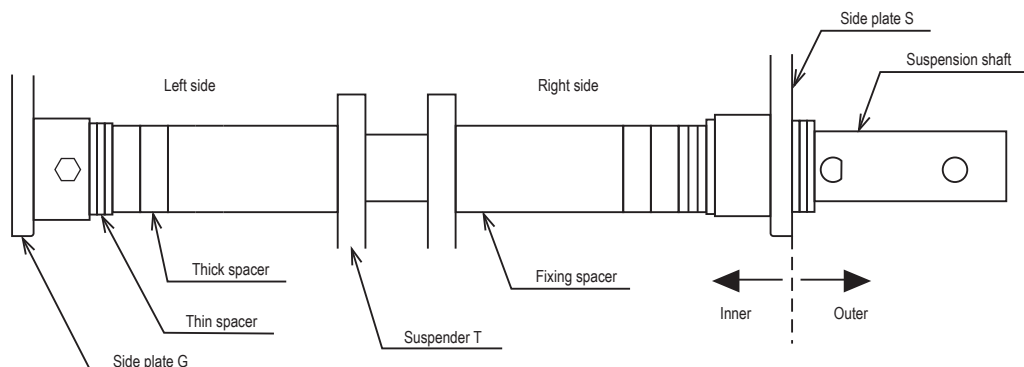

- **Manual Trolley**

Same as the Motorized Trolley table.

■ Checking Power and Power Cable

DANGER



Mandatory

- Check that the source voltage meets the rated voltage of the electric chain hoist.
- Check that the rating of the breaker meets the specifications of the electric chain hoist.

Failure to comply with this instruction may result in death or serious injury.

● Hook (ER2) and Manual Trolley (ER2SG) mount

Code		Cable size (mm ²)	Capacity of fuse and circuit breaker (A)				Cable size (AWG)	230/460V
			200V class	400V class	500V class	Single speed		
-	ER2SG075S	2	20	15	10	AWG14	Single speed	
-	ER2SG100L						30/10	
ER2-100S	ER2SG100S	8	40	30	15	AWG10	Single speed	
ER2-150S	ER2SG150S						50/20	
ER2-200S	ER2SG200S							

● Motorized Trolley (ER2M) mount

Code		Cable size (mm ²)	Capacity of fuse and circuit breaker (A)				Cable size (AWG)	230/460V
			200V class	400V class	500V class	ER Single MR Single		
ER2M075S-L	3.5	30	20	20	AWG12	30/15		
ER2M100L-L								
ER2M100S-L	8	60	40	20	AWG10	60/30		
ER2M150S-L								
ER2M200S-L								

● Checking the Power Cable

⚠ CAUTION



Prohibited

- Do not use the cable other than the accompanying cable or optional power cable.

Failure to comply with this instruction causes bodily injury or loss of property.



Mandatory

- Do not use the power supply cables beyond their maximum length or cable size.

Failure to comply with this instruction causes bodily injury or loss of property.

Code	Cable size (mm ²)	200V class		400V class		500V class	230/460V											
		Single speed						Cable size (mm ²)	Single speed									
		50Hz	60Hz	50Hz	60Hz	50Hz	60Hz											
		220-230V	220-230V	380-415V	380-440V		208-230V		415-460V									
-	ER2SG075S	2	21	18	59	56	108	AWG14 (AWG12)	16	68								
-	ER2SG100L	(3.5)	(37)	(32)	(103)	(99)	(189)		(28)	(119)								
ER2-100S	ER2SG100S	8	42	37	118	113	216	AWG10 (AWG8)	22	93								
ER2-150S	ER2SG150S										(14)	(75)	(64)	(207)	(198)	(378)	(32)	(136)
ER2-200S	ER2SG200S																	

Code	Cable size (mm ²)	200V class		400V class		500V class	230/460V				
		Single speed						Cable size (mm ²)	ER Single-MR Single		
		50Hz	60Hz	50Hz	60Hz	50Hz	60Hz				
		220-230V	220-230V	380-415V	380-440V		208-230V		415-460V		
ER2M075S-L	3.5 (5.5)	27	24	71	71	138	AWG12 (AWG10)	21	90		
ER2M100L-L		(42)	(38)	(111)	(112)	(217)				(34)	(142)
ER2M100S-L	8 (14)	36	32	96	95	182	AWG10 (AWG8)	19	80		
ER2M150S-L		(63)	(56)	(169)	(166)	(319)				(28)	(117)
ER2M200S-L		(54)	(49)	(142)	(143)	(276)				(25)	(103)

NOTE) Figures in parentheses () mean the cable one size larger than the standard size.

■ Connecting Cables

⚠ DANGER



Mandatory

- Be sure to turn off the power supply before wiring work.

Failure to comply with this instruction causes fatal or serious injury due to electrical shock.

NOTE

- Do not fastening the cable plugs by using a tool and be sure to fasten them by hand.
Tightening excessively a connector may result in damaging or breaking plastic threads.
- To prevent the cable from disconnecting or coming off, secure the strain relief wire of the push button cord to the hoist or trolley body.

■ Hook Suspensions for 10t (S) or more

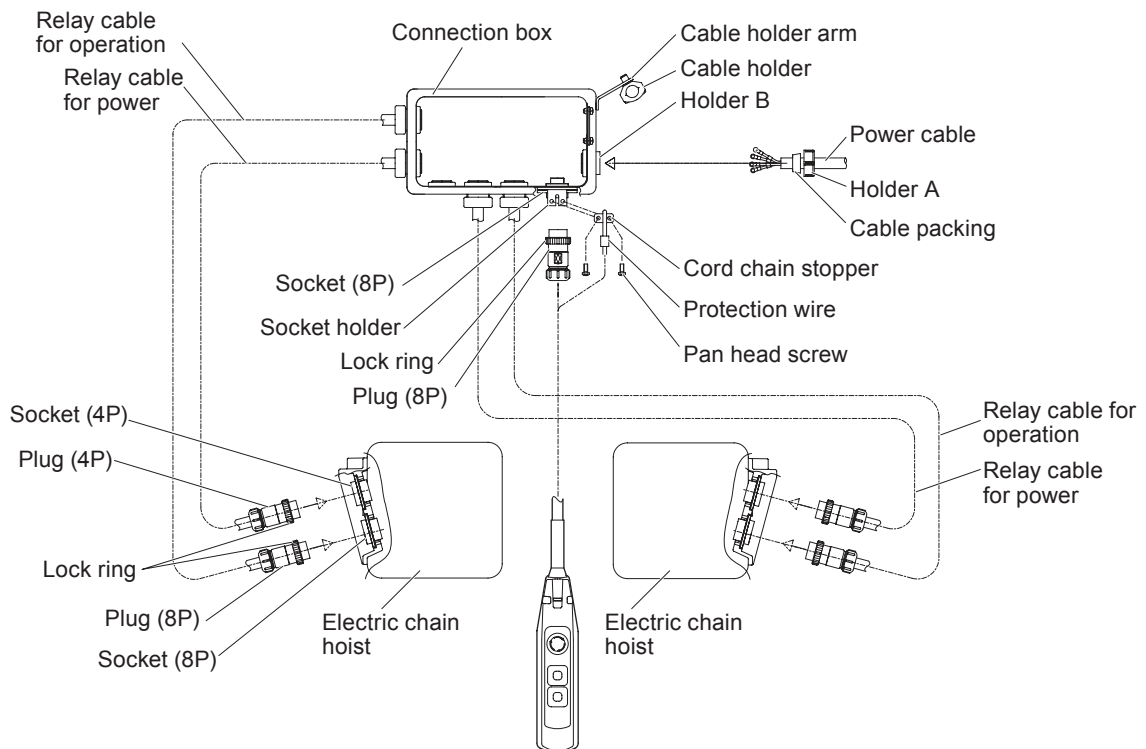

- **Connecting the relay cable**

- 1) Insert the plugs (4P) of the relay cable for power into the sockets (4P) of each of 2 hoists, and securely tighten the lock rings.

- 2) Insert the plugs (8P) of the relay cable for operation into the sockets (8P) of each of 2 hoists, and securely tighten the lock rings.

- **Connecting the push button switch cord**

- 1) Insert the plug (8P) of the push button switch cord into the socket (8P), and securely tighten the lock ring.

- 2) Insert the cord chain stopper into the end ring of the protection wire, and fix the stopper to the socket holder with a pan head screw.

- **Connecting the power cable**

- 1) Remove holder A installed on the connection box.

- 2) Remove the cable packing from the power cable, and pass holder A through the power cable.

- 3) Pass the cable packing through the power cable (see the figure P15), and then insert it into the connection box.

- 4) Tighten holder A, and fix the power cable to the connection box.

- 5) Connect the power cable to the terminal panel in the connection box.
(Refer to the wiring diagram on the connection box to perform wiring correctly.)

- 6) Fix the cable holder on the power cable to the cable holder arm.

Motorized Trolley

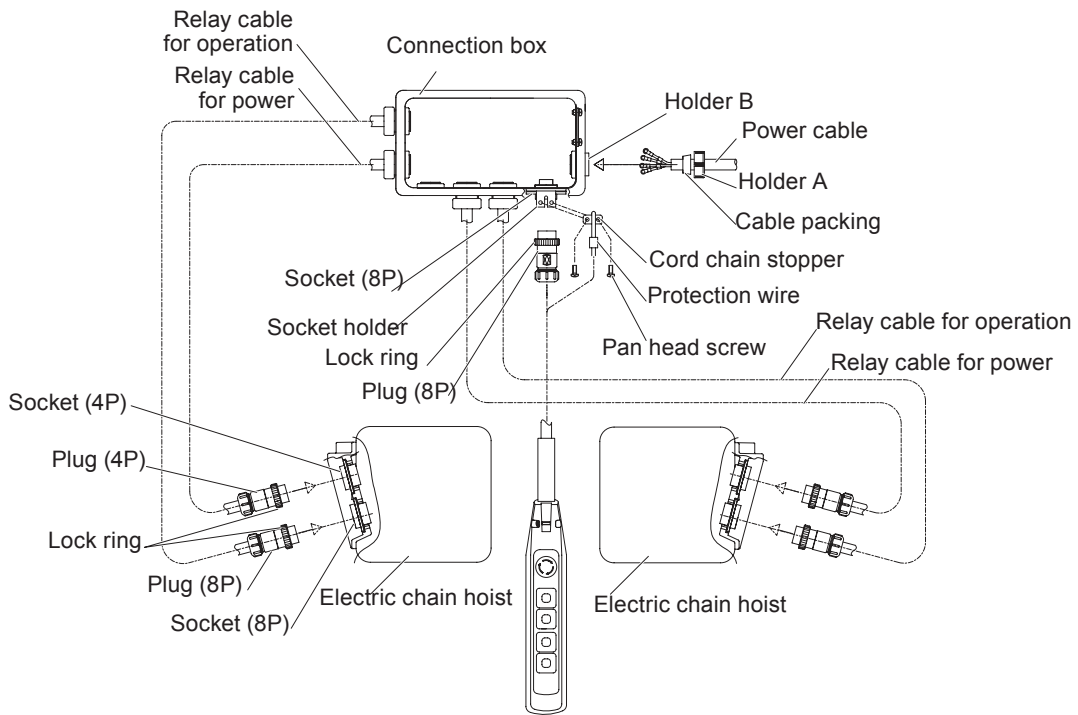

<15t-20t Push Button Switch Cord>

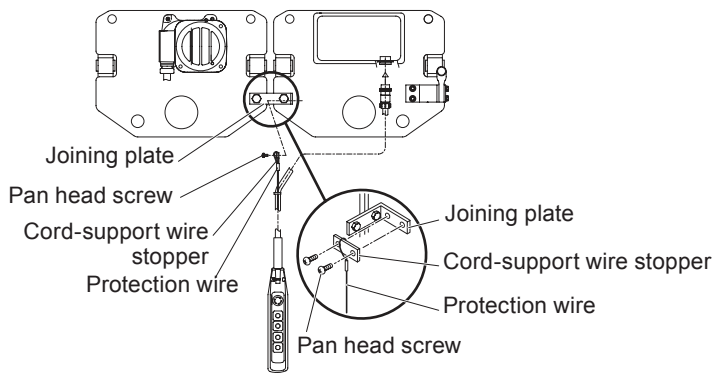

<Trolley Power Cable Connection>

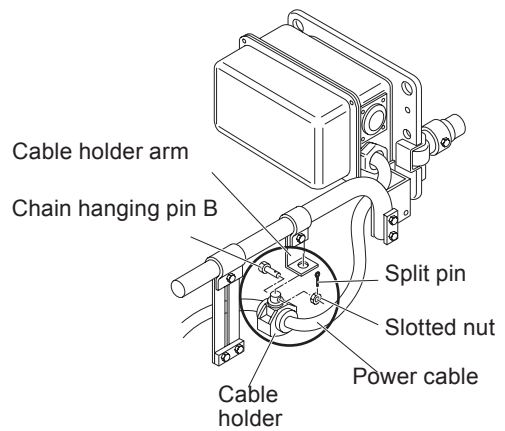

<Direct-mount Push Button Switch Cord Connection>

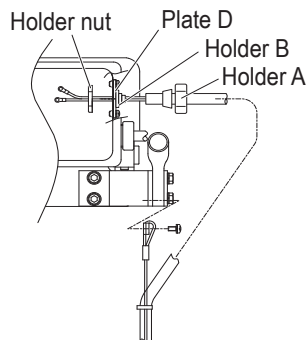

- **Connecting the relay cable**

- 1) Insert the plugs (4P) of the relay cable for power into the sockets (4P) of each of 2 hoists, and securely tighten the lock rings.
- 2) Insert the plugs (8P) of the relay cable for operation into the sockets (8P) of each of 2 hoists, and securely tighten the lock rings.

- **Connecting the push button switch cord**

- 1) Insert the plug (8P) of the push button switch cord into the socket (8P), and securely tighten the lock ring.
 - **Direct-mount**
 - 1) Mount the Holder B, which the Push Button Switch Cord is passed, to the plate D using the holder nut.
 - 2) Connect the Push Button Switch Cord to the terminal panel of the Connection Box.
- 2) Insert the cord chain stopper into the end ring of the protection wire, and fix the stopper to the socket holder with a pan head screw. For 15t and 20t, fix the cord-support wire stopper to the joining plate with a pan head screw.

- **Connecting the power cable**

- 1) Remove holder A installed on the connection box.
- 2) Remove the cable packing from the power supply cable, and pass holder A through the power cable.
- 3) Pass the cable packing through the power cable (see the figure P17), and then insert it into the connection box.
- 4) Tighten holder A, and fix the power cable to the connection box.
 - **Trolley Type**
 - 1) Mount the cable holder, which the Power Cable is passed, to the cable holder arm using a chain hanging pin B, a slotted nut and a split pin.
- 5) Connect the power cable to the terminal panel on the connection box.
(Refer to the wiring diagram on the connection box to perform wiring correctly.)
- 6) Fix the cable holder on the power cable to the cable holder arm.

Manual Trolley Type (7.5t, 10t(L))

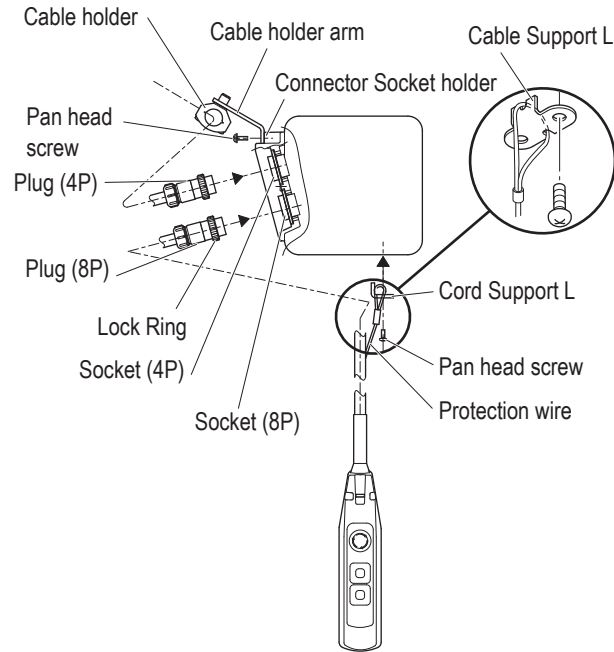

● Connecting the power cable

- 1) Insert the plugs (4P) of the power cable into the sockets (4P) of each of 2 hoists, and securely tighten the lock rings.
- 2) Fix the power cable to the cable holder with a affordable length.

● Connecting the push button switch cord

- 1) Insert the plug (8P) of the push button switch cord into the socket (8P), and securely tighten the lock ring.
- 2) Insert the cord support L into the end ring of the protection wire and set the wire to the notch of the cord support L, and fix the cord support L to the hoist body with a pan head screw.

■ Direct connection

1) Connecting the Power Cable

Insert the Power Cable into the Holder C (upper side) of the Connector Socket holder. Turn the Holder A to connect the cable securely.

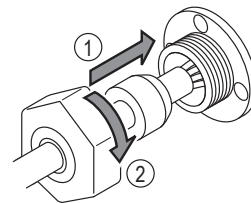

2) Connecting the Push Button Cord

Insert the Push Button Cord into the Holder C (lower side) of the Connector Socket holder. Turn the Holder A to connect the cord securely.

3) Carry out wiring correctly in accordance with the wiring diagram inside the Controller Cover.

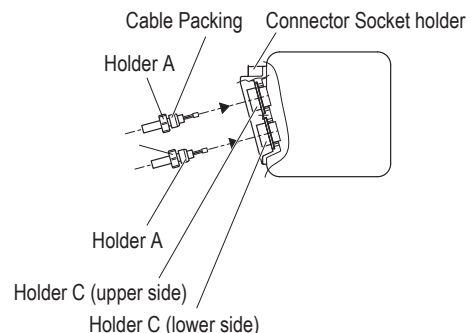

* Items other than the above are the same to those described for Plug Connection.

Regular Inspection

■ Daily Inspection

⚠ DANGER



Mandatory

- Carry out daily inspection before operation.

(When any abnormality is found during inspection, turn off the power, indicate "FAILURE" and ask the maintenance engineer for repair.)

Failure to comply with this instruction causes fatal or serious injury.

For information about the items not shown in the following table, see the ER2 Series Electric Chain Hoist (125kg to 5t) Owner's Manual and perform the inspection.

■ Load chain

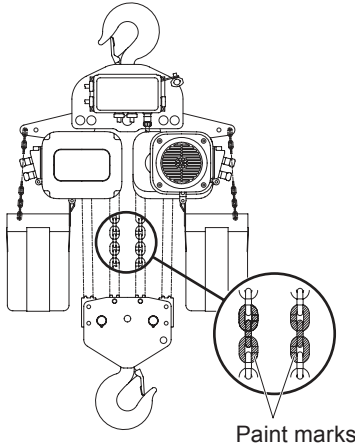
Item	Check method	Criteria	When failed
Paint marks on load chain (except for 7.5t/10t – (L))	<ul style="list-style-type: none"> • Check visually. 	<ul style="list-style-type: none"> • No misalignment in position (Misalignment between upper and lower of paint marks must be within 1m.) * Some misalignment due to differences in hoisting/lowering speed and stop distance between the left and right electric chain blocks is not a fault. 	With no load, lower the chains until both limit switches are triggered.

■ Hook, Idle Sheave

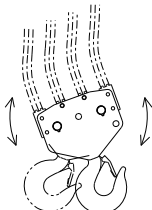
Item	Check method	Criteria	When failed
Tilt of bottom hook Tilt of idle sheave	<ul style="list-style-type: none"> • Check visually and by operation. 	<ul style="list-style-type: none"> • No tilt • Smooth rotation of the idle sheave and no tilt in bottom hook when hoisting/lowering 	Move the load chain or bottom fixture to remove accidental rotation, catching, and twisting.

■ Frequent Inspection

⚠ DANGER



Mandatory

- After completion of the frequent inspection, perform the functional check and make sure that the electric chain hoist operates correctly.

Failure to comply with this instruction causes fatal or serious injury.

NOTE

- When performing frequent inspections, also perform daily inspections.
- When using 2 electric chain blocks (10t or greater), perform inspections on all parts of both units.

For information about the items not shown in the following table, see the ER2 Series Electric Chain Hoist (125kg to 5t) Owner's Manual.

■ Load Chain

- Check the Load Chain after removing all the stain on the chain.
- Use the needle head caliper (point caliper) to measure the multiple pitches and diameter.
- Lubricate the Load Chain after inspection.
- Application of lubricant influences on the life of the Load Chain considerably. Use the KITO genuine lubricant or equivalent (industrial lithium grease: consistency No.0)
- Under no load, apply the lubricant to the linking part of the Load Chain that engages the Load Sheave and the Idle Sheave and the linking part of the Load Chain.
- After application of the lubricant operate the hoist to lift and lower without a load to spread the lubricant on the Load Chain.

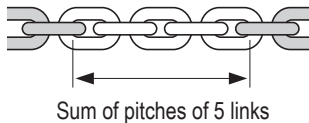
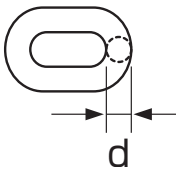
Item	Check method	Criteria	When failed
Elongation of pitch	<ul style="list-style-type: none"> • Measure the sum of pitch for 5 links with point caliper. 	<ul style="list-style-type: none"> • Does not exceed the following limit (common to all capacities) Standard: 157mm Limit: 161.7mm  <p>Sum of pitches of 5 links</p>	Replace the load chain.
Wear of chain diameter	<ul style="list-style-type: none"> • Measure chain diameter with point caliper. 	<ul style="list-style-type: none"> • Does not lower than the following limit. Standard: 11.2mm Limit: 10.1mm  <p>d</p>	Replace the load chain.

■ Hook

Item	Check method	Criteria	When failed							
Opening and wear of hook	<ul style="list-style-type: none"> Check visually and measure with vernier caliper. 	<table border="1"> <thead> <tr> <th>Measured value (mm)</th> <th>Limit value</th> </tr> </thead> <tbody> <tr> <td>Dimension a:</td> <td>does not exceed the size measured at the purchase.</td> </tr> <tr> <td>Dimension b:</td> <td rowspan="2">wear does not exceed 5%</td> </tr> <tr> <td>Dimension c:</td> </tr> </tbody> </table> <ul style="list-style-type: none"> Please be aware that these standard values shown in the table below include tolerance because of forging. 	Measured value (mm)	Limit value	Dimension a:	does not exceed the size measured at the purchase.	Dimension b:	wear does not exceed 5%	Dimension c:	Replace the hook.
Measured value (mm)	Limit value									
Dimension a:	does not exceed the size measured at the purchase.									
Dimension b:	wear does not exceed 5%									
Dimension c:										

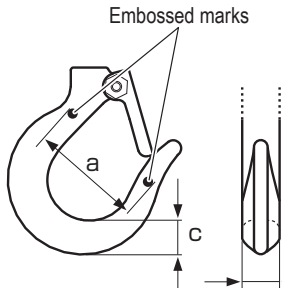

Capacity	Dimension a (mm)	Dimension b (mm)		Dimension c (mm)	
	Standard	Standard	Limit	Standard	Limit
7.5t	121	48	45.6	72.6	69
10t	131	60	57	87	82.7
15t	142	70	66.5	99.4	94.5
20t	181	71	67.5	112	106.4

■ Periodic Inspection

⚠ DANGER



Mandatory

- Put the electric chain hoist on the floor or work bench when inspecting the electric chain hoist.
- After completion of the periodic inspection, perform the functional check and make sure that the electric chain hoist operates correctly.

Failure to perform periodic inspections could result in death or serious injury.

NOTE

- When performing periodic inspections, also perform frequent and daily inspections.
- When using 2 electric chain hoist (10t or greater), perform inspections on all the parts of both hoists.

For information about the items not shown in the following tables, refer to the Kito ER2 Series Electric Chain Hoist (125kg to 5t) Owner's Manual and perform inspection.

■ Electric chain hoist periodic inspection

● Chain spring

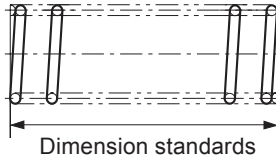
Item	Check method	Criteria	When failed
Deformation	<ul style="list-style-type: none"> • Check visually and measure the dimensions. 	<ul style="list-style-type: none"> • No remarkable deformation <p>Length of chain spring</p> <p>Standard: 160 mm</p> <p>Limit: 152 mm</p> 	Replace the chain spring.

● Oil

Item	Check method	Criteria	When failed
Oil amount and stain	Visual inspection from oil check hole on the side of the hoist	<ul style="list-style-type: none"> Oil does not enter until it approaches the oil surface position. Gear oil has viscosity but not stained. For more information about changing gear oil, see the ER2 Series Electric Chain Hoist (125kg to 5t) Owner's Manual . <p>Gear oil quantity: per hoist</p> <ul style="list-style-type: none"> Friction clutch: 1900ml Friction clutch with mechanical brake: 2700ml 	Add or change oil.

* For friction clutch with mechanical brake, insert an oil dipstick into the oil inspection hole on the top of the hoist to check a level of the oil quantity. The level should be 130mm from the hole. (Please refer to the Kito ER2 Series Electric Chain Hoist (125kg to 5t) Owner's Manual.)

● Electromagnetic brake (gap)

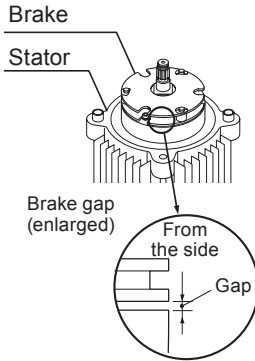
Item	Check method	Criteria	When failed
Gap	Measure the gap with thickness gauge.	<ul style="list-style-type: none"> Do not exceed the limit Limit: 1.1 mm 	Replace the electromagnetic brake.

● Load sheave/idle sheave

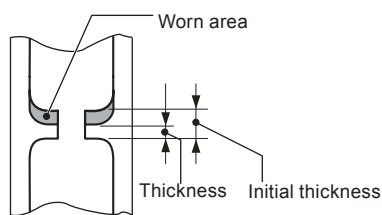
Item	Check method	Criteria	When failed
Wear and flaw	Check visually and measure the dimensions.	<ul style="list-style-type: none"> To have no significant wear, deformation and damage To have neither wear nor run-on flaw on the sheave pocket. <p>Should not be below the limit Standard thickness value: 7.3mm Abration threshold value: 4.9mm</p> 	Replace the applicable parts.

● Load sheave/idle sheave (Continued)

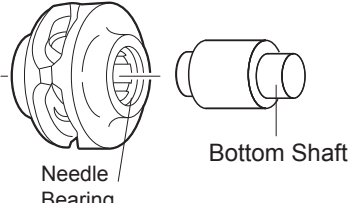
Item	Check method	Criteria	When failed
<p>Abrasion and flaw of the Needle Bearing for Idle Sheave and Bottom Shaft.</p>  <p>Needle Bearing Bottom Shaft</p>	<p>Wipe off the grease applied inside of the Idle Sheave and Needle Bearing, and check visually for Needle Bearing and Bottom Shaft.</p>	<ul style="list-style-type: none"> No deformation and damage. The idle Sheave rotate smoothly. After having maintenance and have no abnormalities, apply grease inside adequately Timing of change the grease (Refer to “the ER2 Series Electric Chain Host (125kg to 5t) Owner’s Manual.” (P91) .) 	<p>Replace the Idle Sheave.</p>

■ Electric trolley periodic inspection

● Brake (amount of wear)

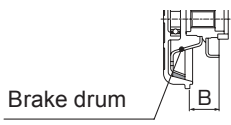
Item	Check method	Criteria	When failed
<p>Wear of brake pad</p>	<p>Disassemble the Brake and measure the size B. (Measure the size so that the break drum is attached to the motor cover.)</p>	<ul style="list-style-type: none"> Should not be below the limit <p>Standard for dimension B: 32.5mm Limit for dimension B: 31mm</p>  <p>Brake drum</p>	<p>Replace the motor cover.</p>

● Wheel (amount of wear)

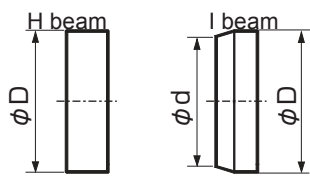
Item	Check method	Criteria	When failed
<p>Amount of wear</p>  <p>H beam I beam ϕD ϕd ϕD</p>	<p>Measure outer diameter with vernier caliper.</p>	<ul style="list-style-type: none"> Should not be below the limit <p>(For I beam) Standard for dimension D: 175mm Limit: 165mm Standard for dimension d: 166mm Limit: 156mm</p> <p>(For H beam) Standard for dimension D: 175mm Limit for dimension D: 165mm</p>	<p>Replace the Wheel.</p>

● Side roller (amount of wear)

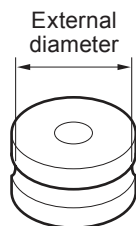
Item	Check method	Criteria	When failed
<p>Amount of wear</p>	<p>Measure outer diameter with vernier caliper.</p>	<ul style="list-style-type: none"> Should not be below the limit <p>Standard: 55mm Limit: 54mm</p>  <p>External diameter</p>	<p>Replace the side roller.</p>

Manual trolley periodic inspection

● Wheel

Item	Check method	Criteria	When failed																
Amount of wear	<ul style="list-style-type: none"> Measure outer diameter and flange with vernier caliper. <div style="text-align: center;"> </div>	<ul style="list-style-type: none"> Should not be below the limit <p>(For I beam)</p> <table> <tr> <td>Standard for dimension D:</td> <td>155mm</td> </tr> <tr> <td>Limit:</td> <td>148mm</td> </tr> <tr> <td>Standard for dimension d:</td> <td>145mm</td> </tr> <tr> <td>Limit:</td> <td>139mm</td> </tr> </table> <p>(For H beam)</p> <table> <tr> <td>Standard for dimension D:</td> <td>147mm</td> </tr> <tr> <td>Limit:</td> <td>140mm</td> </tr> </table> <p>(Common)</p> <table> <tr> <td>Standard for dimension t:</td> <td>13mm</td> </tr> <tr> <td>Limit:</td> <td>9mm</td> </tr> </table>	Standard for dimension D:	155mm	Limit:	148mm	Standard for dimension d:	145mm	Limit:	139mm	Standard for dimension D:	147mm	Limit:	140mm	Standard for dimension t:	13mm	Limit:	9mm	Replace the Wheel.
Standard for dimension D:	155mm																		
Limit:	148mm																		
Standard for dimension d:	145mm																		
Limit:	139mm																		
Standard for dimension D:	147mm																		
Limit:	140mm																		
Standard for dimension t:	13mm																		
Limit:	9mm																		

NOTE

- For information about the troubleshooting, see Chapter 3 of the KITO ER2 Series Electric Chain Hoist (125kg to 5t) Owner's Manual.

Appendix

■ Wiring Diagram of Single Speed ER(10tL),ERSG (7.5/10tL) ■ 200V class 400V class, 500V class (Plug Connection)

Parts No	NAME
1 T~	Transformer
2 F~	Fuse
3 B~	Electromagnetic Brake
4 CHM	Counter/Hour Meter
5 G11	Rectifier
6 M11	Hoist Motor
7 K~	Contact
8 X~	Plug/Socket/Connector
9 TP~	Motor Thermal Protector
10 LS11	Upper Limit Switch
11 LS12	Lower Limit Switch

Abbreviation
Bk: Black
Gn/Ye: Green/Yellow
Rd: Red
Wh: White
Bn: Brown
Gy: Gray
Or: Orange
EM: Emergency Stop
Be: Blue
Gn: Green
Ye: Yellow

Note

- Capacity: ERSG075S/ERSG(ER) 100L
- Operation Type
Hoist: Single Speed
- Power Supply
200V class, 400V class, 500V class
50/60Hz, 3 Phase
- Push Button Connection
Plug Connection

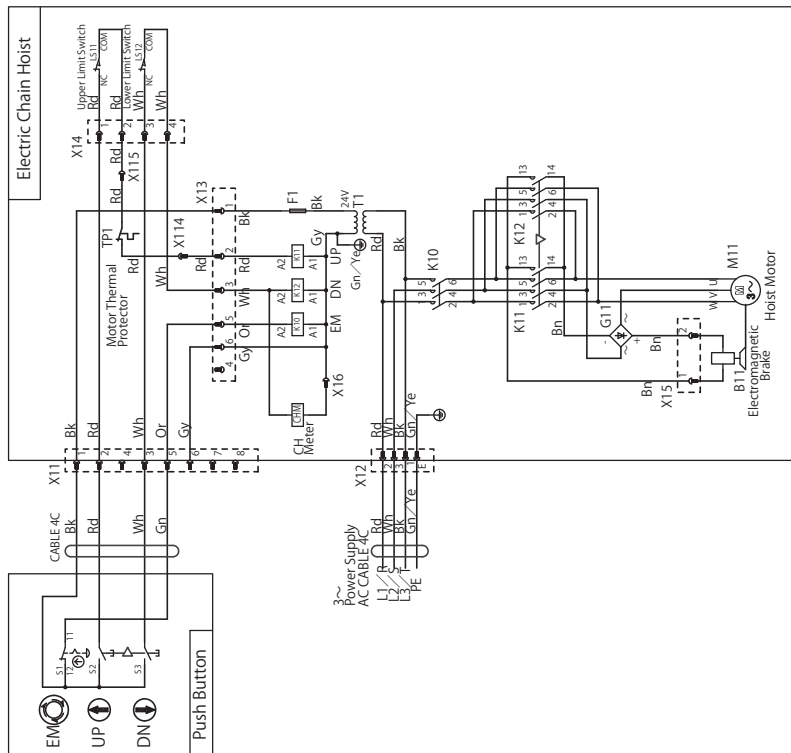

■ 200V class 400V class, 500V class (Direct Connection)

Parts No	NAME
1	Transformer
2	Fuse
3	Electromagnetic Brake
4	Counter/Hour Meter
5	G11 Rectifier
6	M11 Hoist Motor
7	Contact
8	X~ Plug/Socket/Connector
9	TP~ Motor Thermal Protector
10	LS11 Upper Limit Switch
11	LS12 Lower Limit Switch

Abbreviation
Bk: Black
Rd: Red
Wh: White
Bn: Brown
Gy: Gray
Or: Orange
Be: Blue
Gn: Green
Ye: Yellow

- Note**
- Capacity: ERSG075S/ERSG(ER)100L
 - Operation Type
Hoist: Single Speed
 - Power Supply
200V class, 400V class, 500V class
50/60Hz, 3Phase
 - Push Button Connection
Direct Connection

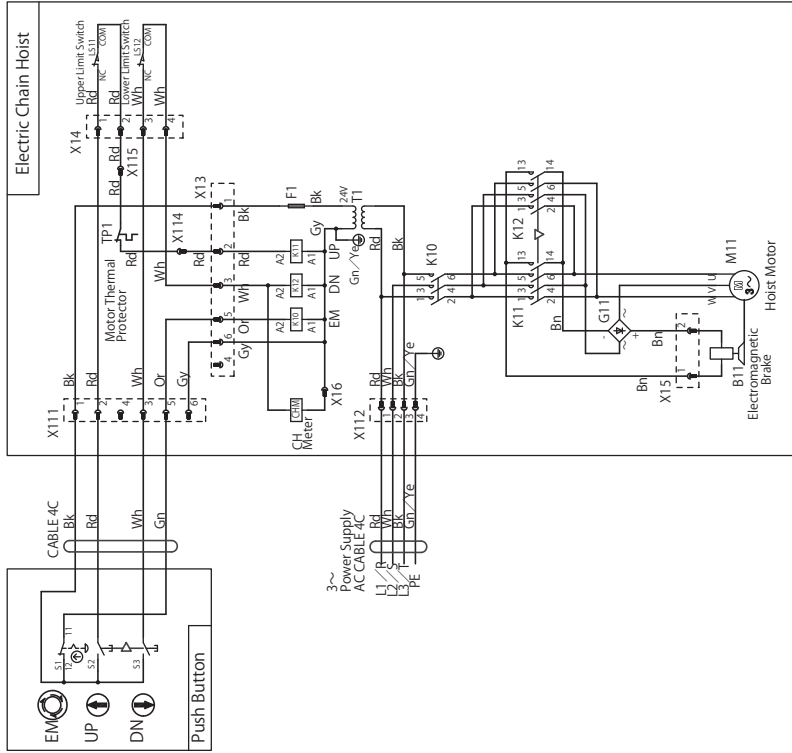

■ 230/460V class (208-230V) (Plug Connection)

Parts No	NAME
1	T~ Transformer
2	F~ Fuse
3	B~ Electromagnetic Brake
4	CHM Counter/Hour Meter
5	G11 Rectifier
6	M11 Hoist Motor
7	K~ Contactor
8	X~ Plug/Socket/Connector
9	TP~ Motor Thermal Protector
10	LS11 Upper Limit Switch
11	LS12 Lower Limit Switch
12	TB~ Terminal Block

Abbreviation
Bk: Black
Rd: Red
Wh: White
Bn: Brown
Gy: Gray
Or: Orange
Be: Blue
Gn: Green
Ye: Yellow

Note

1.Capacity: ERSG075S/ERSG(ER)100L

2.Operation Type

Hoist: Single Speed

3.Power Supply

208~230V,60Hz,3Phase

4.Push Button Connection

Plug Connection

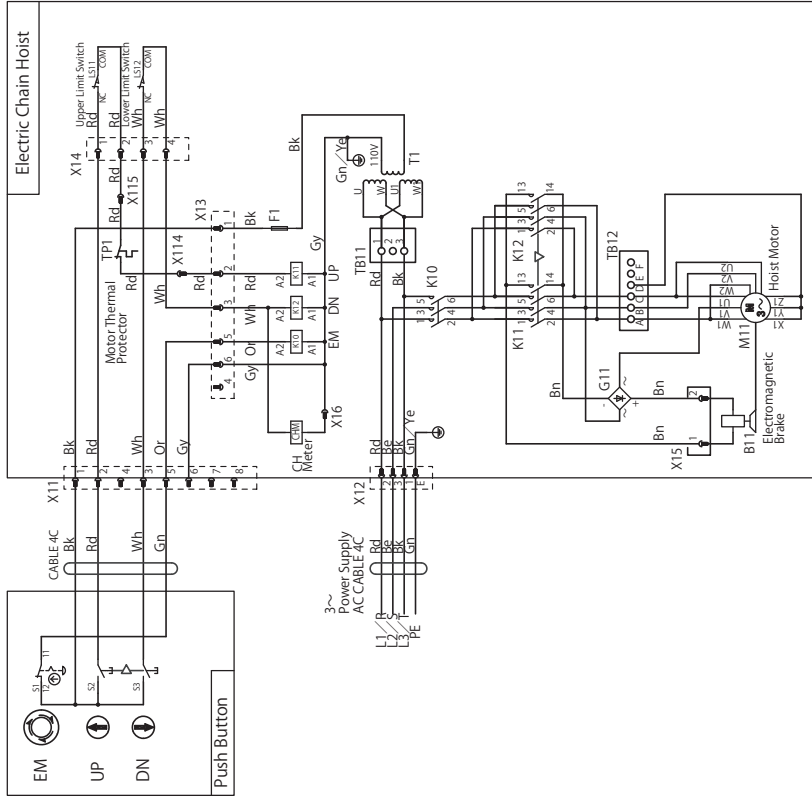

■ 230/460V class (415-460V) (Plug Connection)

Parts No	NAME
1	Transformer
2	Fuse
3	Electromagnetic Brake
4	Counter/Hour Meter
5	Rectifier
6	Hoist Motor
7	Contact
8	Plug/Socket/Connector
9	Motor Thermal Protector
10	Upper Limit Switch
11	Lower Limit Switch
12	Terminal Block

Abbreviation	
Bk: Black	Gn/Ye: Green/Yellow
Rd: Red	
Wh: White	
Bn: Brown	
Gy: Gray	
Or: Orange	EM: Emergency Stop
Be: Blue	EM: UP
Gn: Green	EM: DN
Ye: Yellow	

- Note
- Capacity: ERSG075S/ERSG(ER)100L
 - Operation Type
Hoist: Single Speed
 - Power Supply
415~460V, 60Hz, 3Phase
 - Push Button Connection
Plug Connection

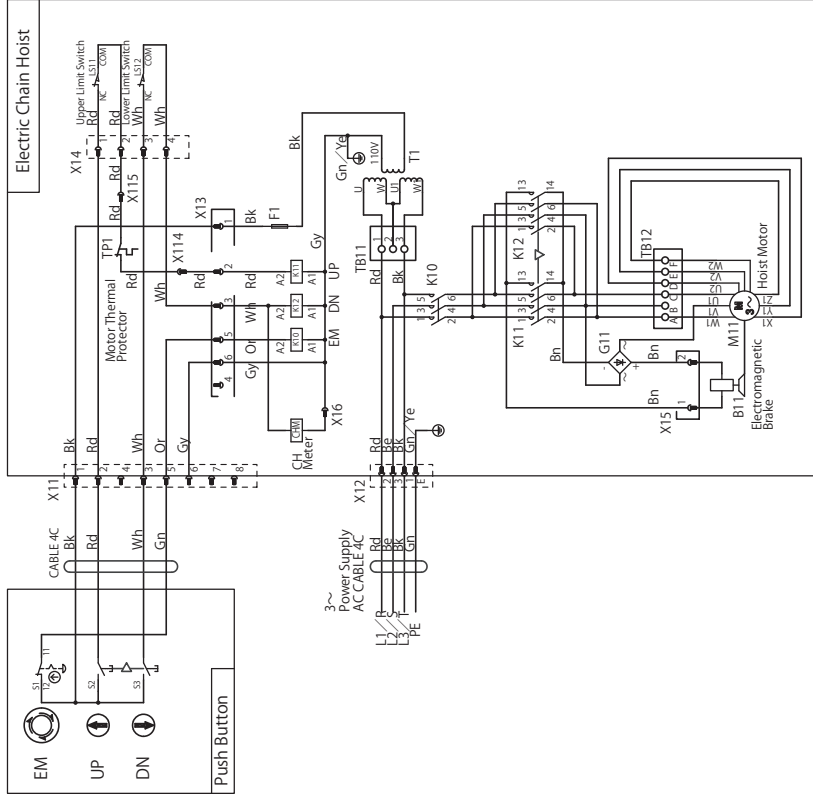

Wiring Diagram of Single Speed ER (10 to 20t), ERSG (10 to 20t)

200V class 400V class, 500V class (Plug Connection)

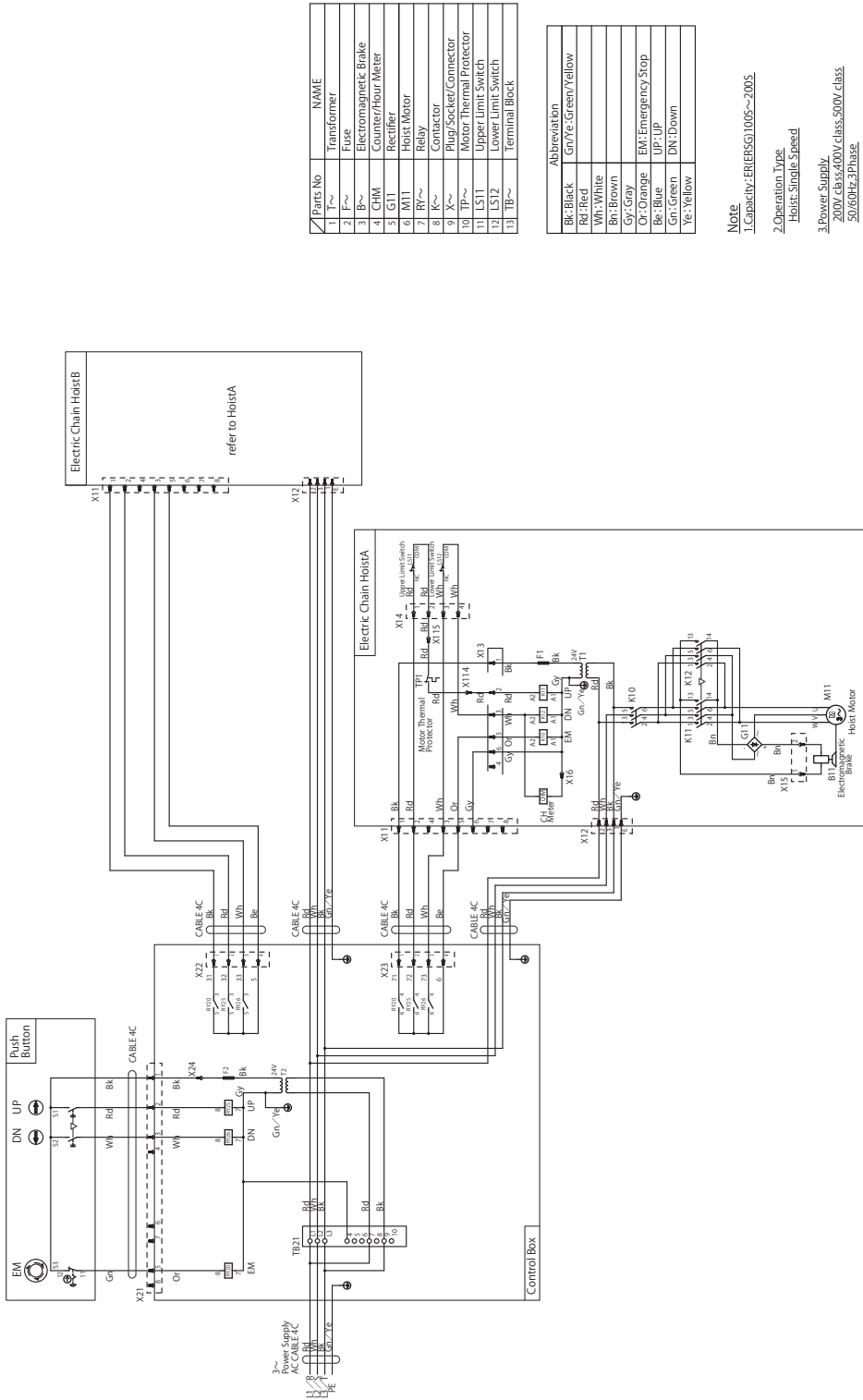

Parts No	NAME
1	Transformer
2	Fuse
3	Electromagnetic Brake
4	Counter/hour Meter
5	Rectifier
6	Hoist Motor
7	Relay
8	Contactor
9	Plug/Socket/Connector
10	Motor Thermal Protector
11	Upper Limit Switch
12	Lower Limit Switch
13	Terminal Block

Abbreviation
Bk:Black
Rd:Red
Wh:White
Bn:Brown
Gy:Gray
Or:Orange
Bl:Blue
Gn:Green
Ye:Yellow

- Note**
- Capacity: ER(ERSG)100S~200S.
 - Operation Type
Hoist: Single Speed
 - Power Supply
200V class/400V class/500V class
50/60Hz/3Phase
 - Push Button Connection
Plug Connection

■ 200V class 400V class, 500V class (Direct Connection)

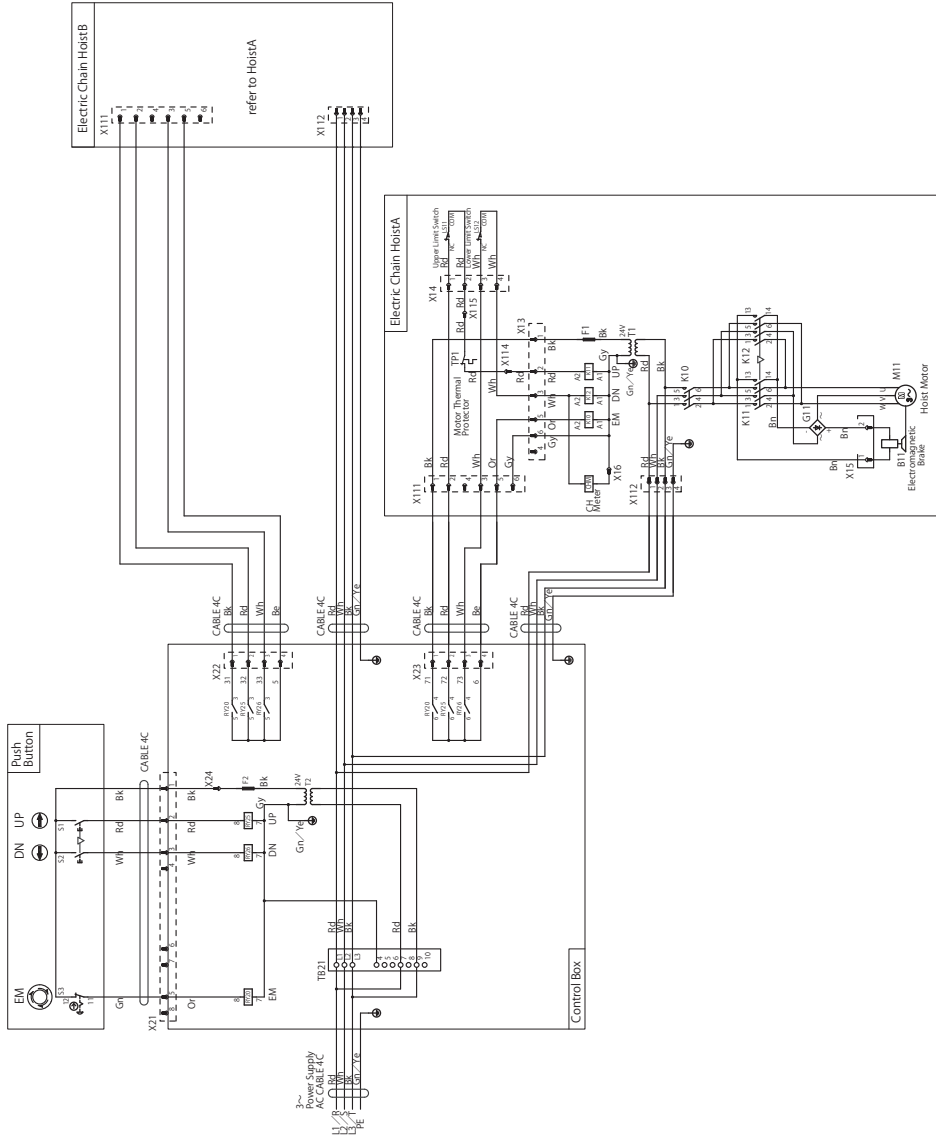

Parts No	NAME
1	Transformer
2	Fuse
3	Electromagnetic Brake
4	Counter/Hour Meter
5	Rectifier
6	Hoist Motor
7	Relay
8	Contactor
9	Plug/Socket/Connector
10	Motor Thermal Protector
11	Upper Limit Switch
12	Lower Limit Switch
13	Terminal Block

Abbreviation	Color
Bk	Black
Rd	Red
Wh	White
Bn	Brown
Gy	Gray
Or	Orange
Bl	Blue
Gn	Green
Ye	Yellow

- NOTE**
- Capacity: ER(ERSG)100S~200S
 - Operation Type
Hoist: Single Speed
 - Power Supply
200V class, 400V class, 500V class
50/60Hz, 3 Phase
 - Push Button Connection
Plug Connection

230/460V class (208-230V) (Plug Connection)

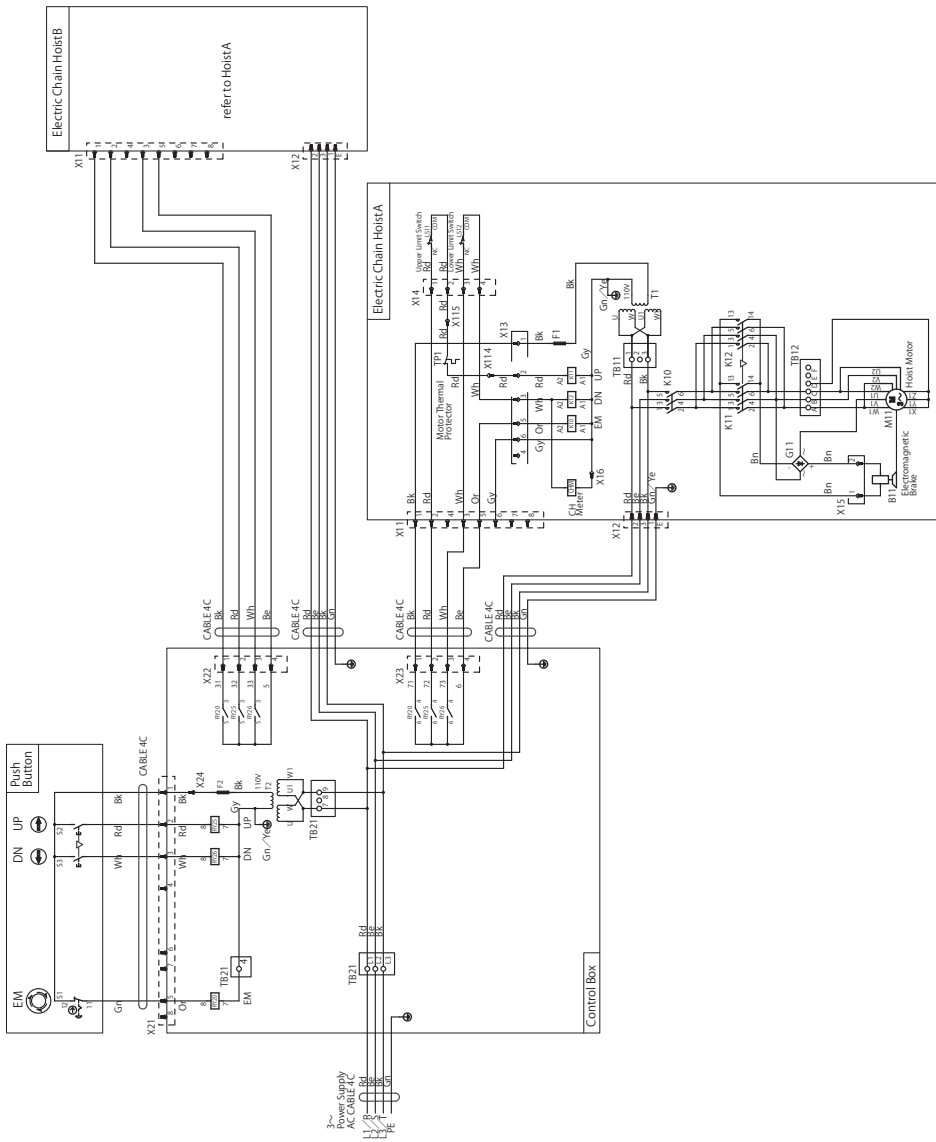

Parts No	NAME
1	Transformer
2	Fuse
3	Electromagnetic Brake
4	CHM Counter/Hour Meter
5	Rectifier
6	IM11 Hoist Motor
7	RV~ Relay
8	K~ Contactor
9	X~ Plug/Socket/Connector
10	TP~ Motor Thermal Protector
11	LS11 Upper Limit Switch
12	LS12 Lower Limit Switch
13	TB~ Terminal Block

Abbreviation
Bk: Black
Rd: Red
Wh: White
Br: Brown
Gy: Gray
Or: Orange
Bl: Blue
Gn: Green
Ye: Yellow

- Note**
- Capacity: E(ERSG)1005~2005
 - Operation Type
Hoist: Single Speed
 - Power Supply
208~230V, 60Hz, 3-Phase
 - Push Button Connection
Plug Connection

■ 230/460V class (415-460V) (Plug Connection)

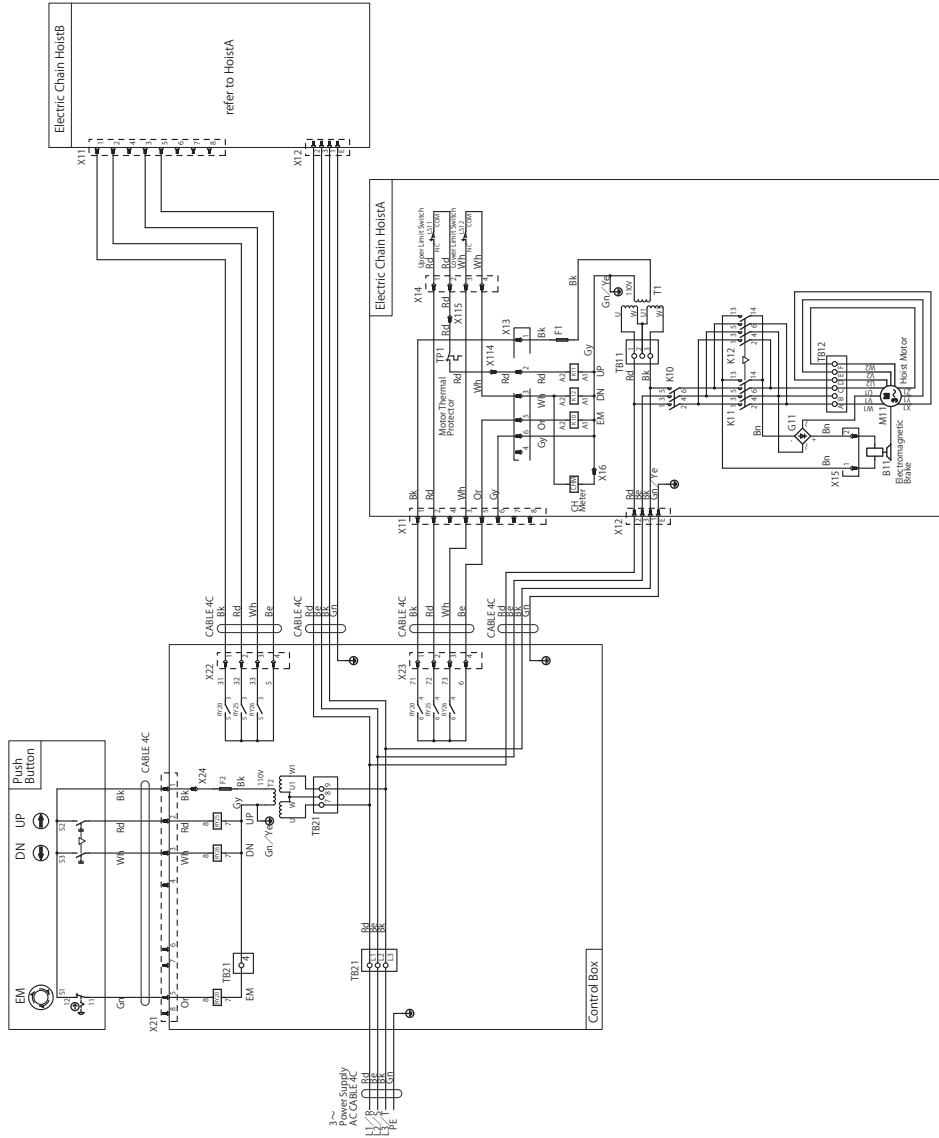

Parts No	NAME
1 F~	Transformer
2 F~	Fuse
3 B~	Electromagnetic Brake
4 CHM	Counter/Hour Meter
5 G11	Receiver
6 M11	Hoist Motor
7 RY~	Relay
8 K~	Contactor
9 X~	Plug/Socket/Connector
10 TP~	Motor Thermal Protector
11 LS1	Upper Limit Switch
12 LS2	Lower Limit Switch
13 TB~	Terminal Block

Abbreviation	Color
Bk	Black
Rd	Red
Wh	White
Br	Brown
Gy	Gray
Or	Orange
Bl	Blue
Gn	Green
Ye	Yellow

- Note**
- Capacity: E1ERSG1005~2005
 - Operation Type: Hoist: Single Speed
 - Power Supply: 415~460V/60Hz, 3Phase
 - Push Button Connection: Plug Connection

Wiring Diagram of Single Speed ERM7.5t/10tL

200V class, 400V class, 500V class (Plug Connection)

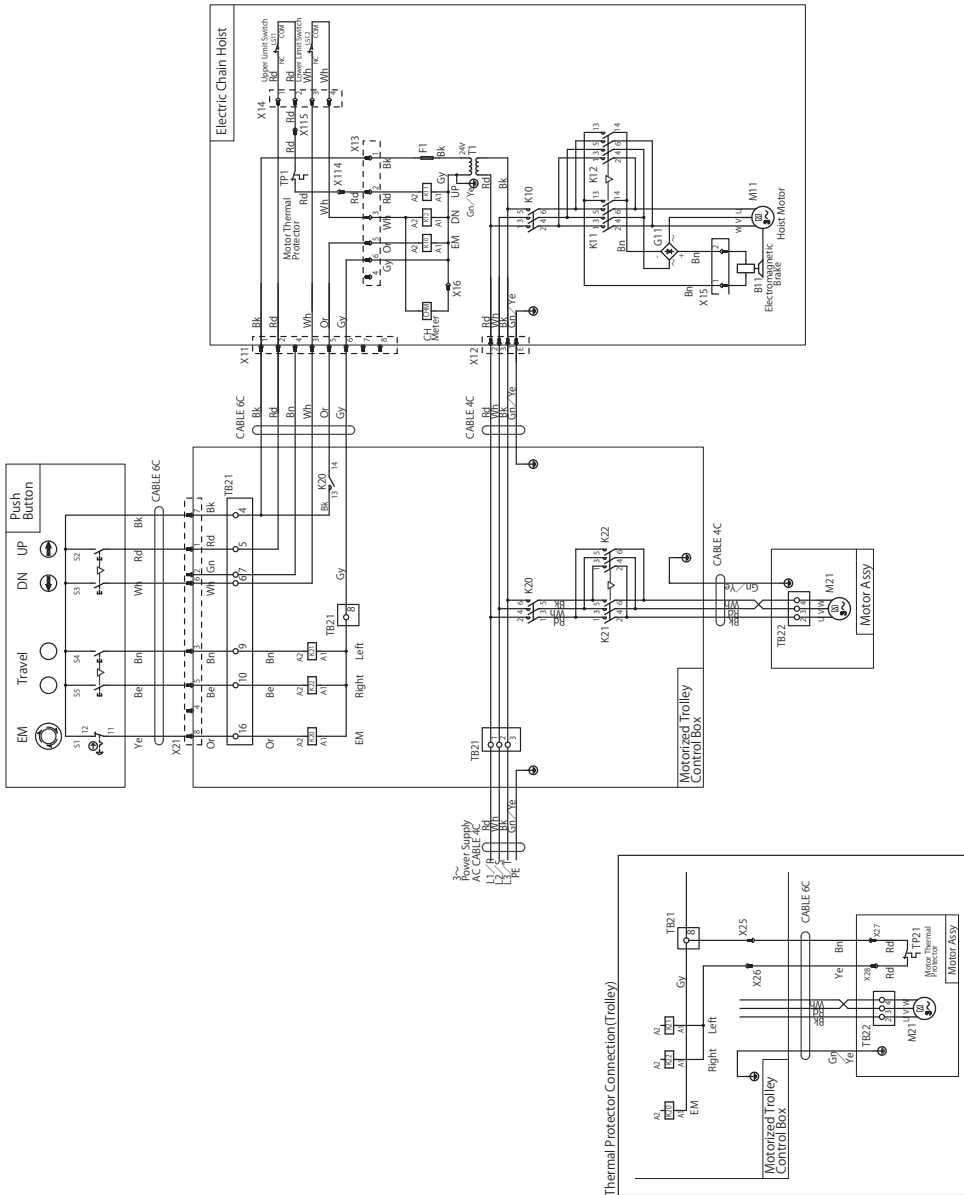

Parts No	NAME
1 TT	Transformer
2 FI	Fuse
3 BT1	Electromagnetic Brake
4 CHM	Counter/Hour Meter
5 GT1	Rectifier
6 MT1	Hoist Motor
7 IMZ1	Trolley Motor
8 K~	Contact
9 X~	Plug/Socket/Connector
10 TP~	Motor Thermal Protector
11 LS11	Upper Limit Switch
12 LS12	Lower Limit Switch
13 TB~	Terminal Block

Abbreviation
Bk:Black
Rd:Red
Wh:White
Bn:Brown
Gy:Gray
Or:Orange
Bc:Blue
Gn:Green
Ye:Yellow

- Note**
- Capacity:ERM07.5/ERM100L
 - Operation Type
Hoist: Single Speed
Trolley: Single Speed
 - Power Supply
200V class, 400V class, 500V class
50/60Hz, 3Phase
 - Plug Connection

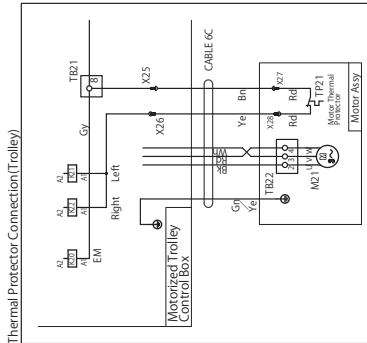

■ 200V class 400V class, 500V class (Direct Connection)

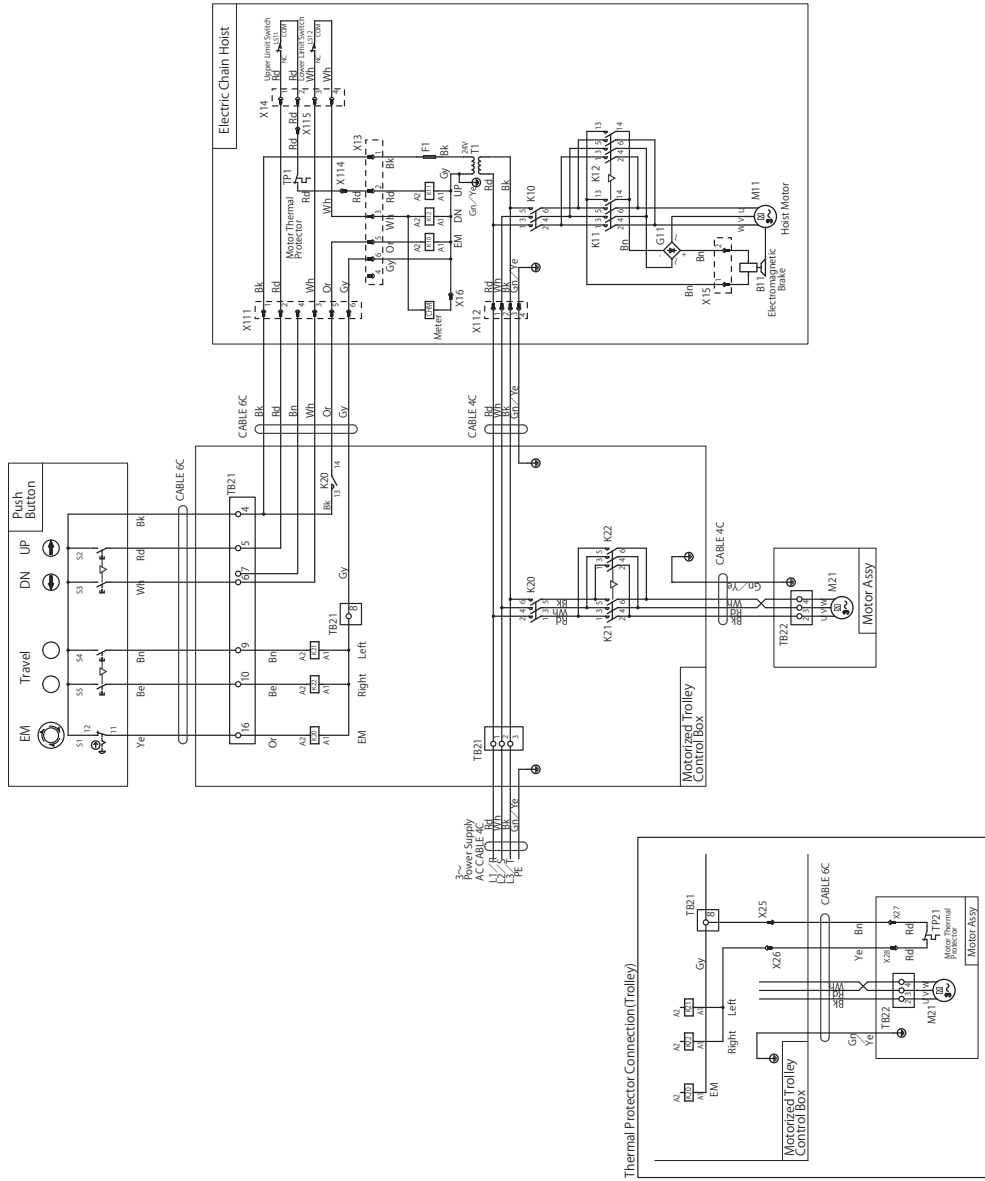

Parts No	NAME
1	TT
2	Transformer
3	F1
4	Fuse
5	B11
6	Electromagnetic Brake
7	CHM
8	Counter/Hour Meter
9	G11
10	Rectifier
11	M11
12	Hoist Motor
13	IM21
14	Trolley Motor
15	K~
16	Contactor
17	X~
18	Plug/Socket/Connector
19	Motor Thermal Protector
20	TP~
21	Upper Limit Switch
22	LS12
23	Lower Limit Switch
24	TB~
25	Terminal Block

Abbreviation
Bk:Black
Rd:Red
Wh:White
Bn:Brown
Gy:Gray
Or:Orange
Bl:Blue
Gn:Green
Ye:Yellow

Note

- Capacity:ERM0755/ERM100L
- Operation Type
Hoist: Single Speed
Trolley: Single Speed
- Power Supply
200V class, 400V class, 500V class
50/60Hz, 3P base
- Push Button Connection
Direct Connection

230/460V class (208-230V) (Plug Connection)

Parts No	NAME
1	T1 Transformer
2	F1 Fuse
3	B11 Electromagnetic Brake
4	CHM Counter/Hour Meter
5	G11 Rectifier
6	M11 Hoist Motor
7	M21 Trolley Motor
8	K~ Contactor
9	X~ Plug/Socket/Connector
10	TP~ Motor Thermal Protector
11	LS11 Upper Limit Switch
12	LS12 Lower Limit Switch
13	TB~ Terminal Block

Abbreviation
Bk:Black
Rd:Red
Wh:White
Bn:Brown
Gy:Gray
Or:Orange
Be:Blue
Gn:Green
Ye:Yellow

- NOTE**
- 1.Capacity:ERM0755/ERM100L
 - 2.Operation Type
Hoist: Single Speed
Trolley: Single Speed
 - 3.Power Supply
208~230V/60Hz,3Phase
 - 4.Push Button Connection
Plug Connection.

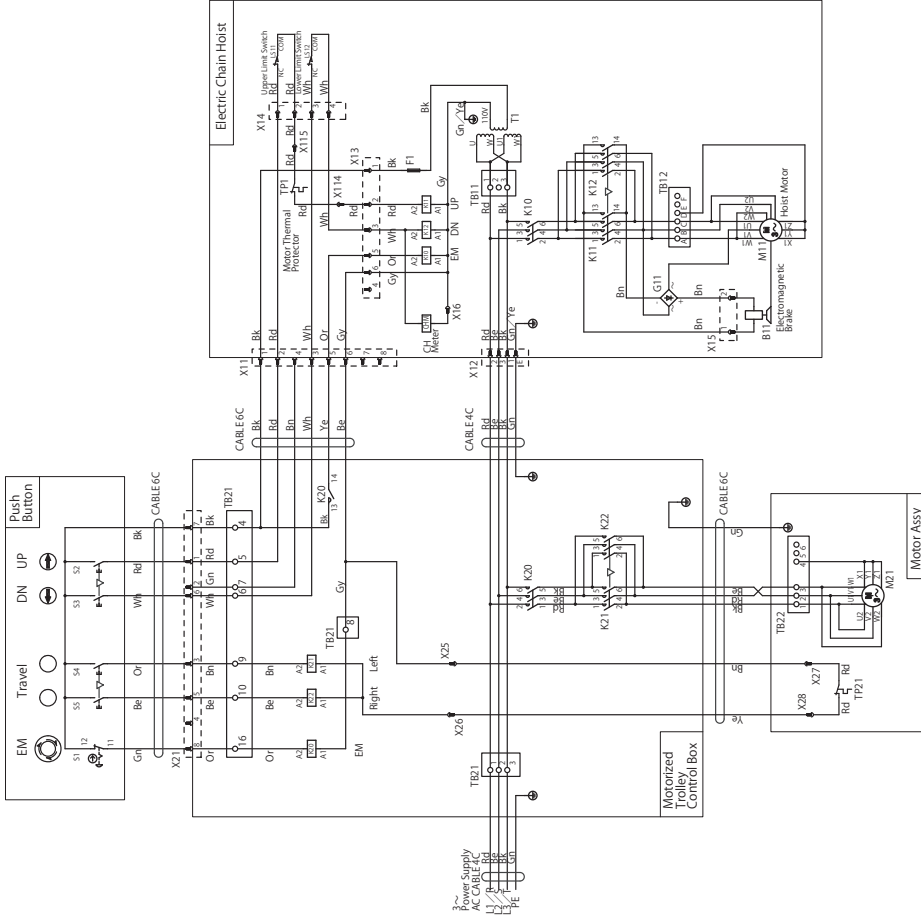

■ 230/460V class (415-460V) (Plug Connection)

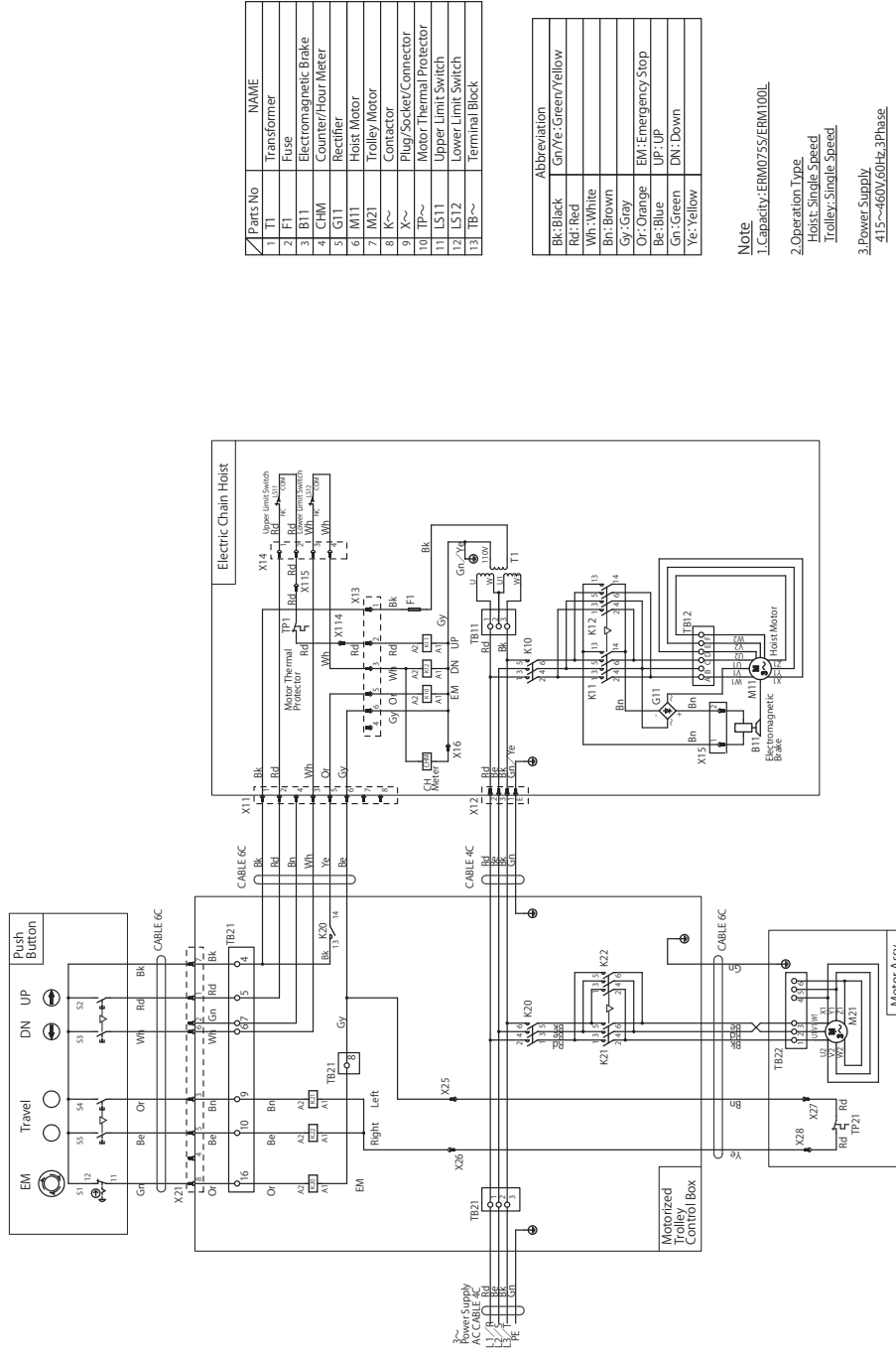

Parts No	NAME
1 T1	Transformer
2 F1	Fuse
3 B11	Electromagnetic Brake
4 CHM	Counter/Hour Meter
5 G11	Rectifier
6 M11	Hoist Motor
7 M21	Trolley Motor
8 K~	Contactor
9 X~	Plug/Socket/Connector
10 TP~	Motor Thermal Protector
11 LS11	Upper Limit Switch
12 LS12	Lower Limit Switch
13 TB~	Terminal Block

Abbreviation
Bk: Black
Gn/Ye: Green/Yellow
Rd: Red
Wh: White
Br: Brown
Gv: Gray
Or: Orange
Em: Emergency Stop
Bc: Blue
Gn: Green
DN: Down
Ye: Yellow

- Note**
- Capacity: ERM0755/ERM100L
 - Operation Type
Hoist: Single Speed
Trolley: Single Speed
 - Power Supply
415~460V/60Hz, 3-Phase
 - Push Button Connection
Plug Connection

Wiring Diagram of Single Speed ERM15/20t

200V class, 400V class, 500V class (Plug Connection)

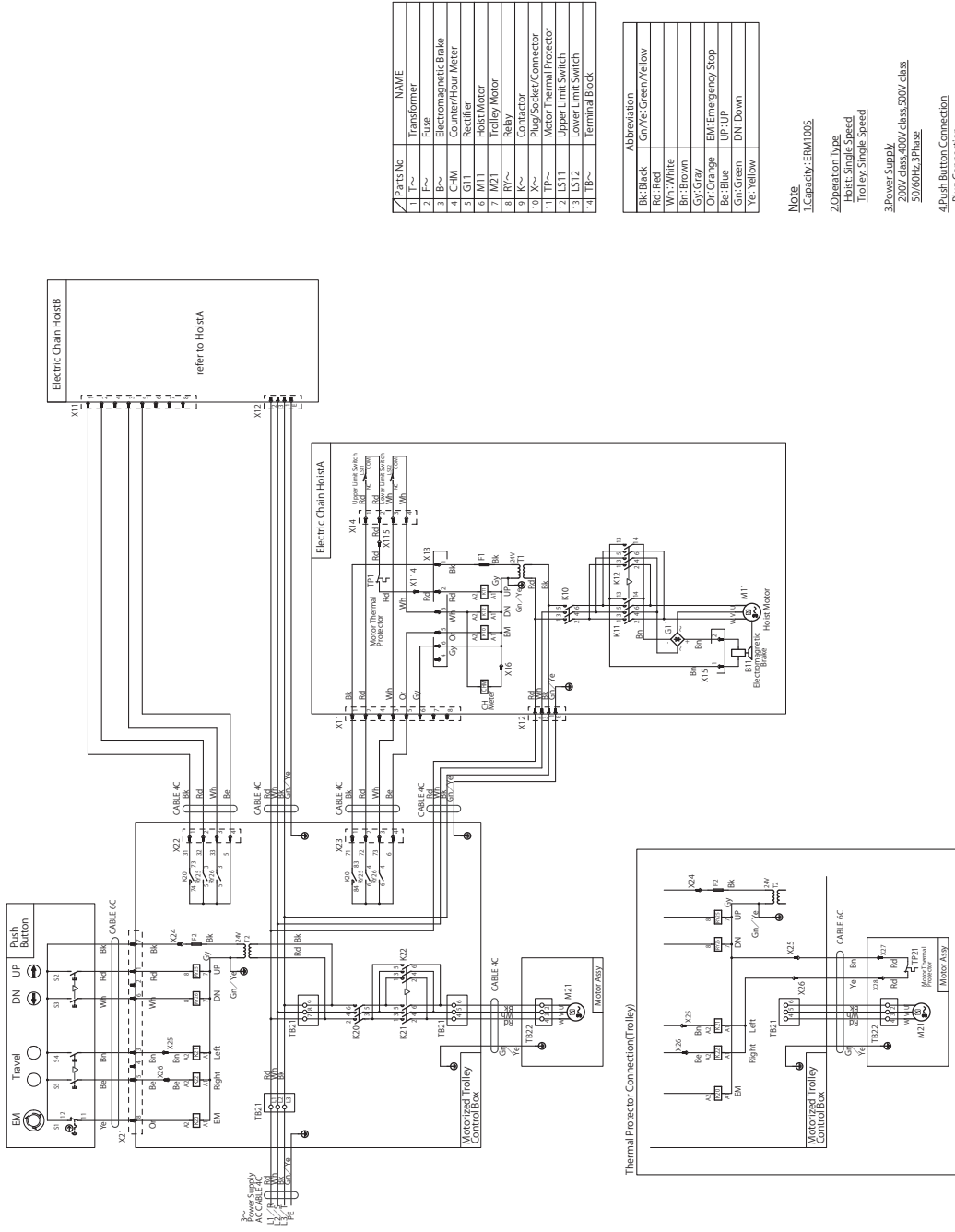

Parts No	NAME
1	Transformer
2	Fuse
3	B~
4	CHM Counter/Hour Meter
5	G11 Rectifier
6	M11 Hoist Motor
7	M21 Trolley Motor
8	RY~ Relay
9	K~ Contactor
10	X~ Plug/Socket/Connector
11	TP~ Motor Thermal Protector
12	LS11 Upper Limit Switch
13	LS12 Lower Limit Switch
14	TP~ Terminal Block

Abbreviation	Color
Bk: Black	Gn/Ye: Green/Yellow
Rd: Red	
Wh: White	
Br: Brown	
Gy: Gray	
Or: Orange	EM: Emergency Stop
Bl: Blue	UP: UP
Gn: Green	DN: Down
Ye: Yellow	

- Note**
1. Capacity: ERM100S
 2. Operation Type: Hoist: Single Speed, Trolley: Single Speed
 3. Power Supply: 200V class, 400V class, 500V class, 50/60Hz, 3Phase
 4. Push Button Connection: Plug Connection

■ 200V class 400V class, 500V class (Direct Connection)

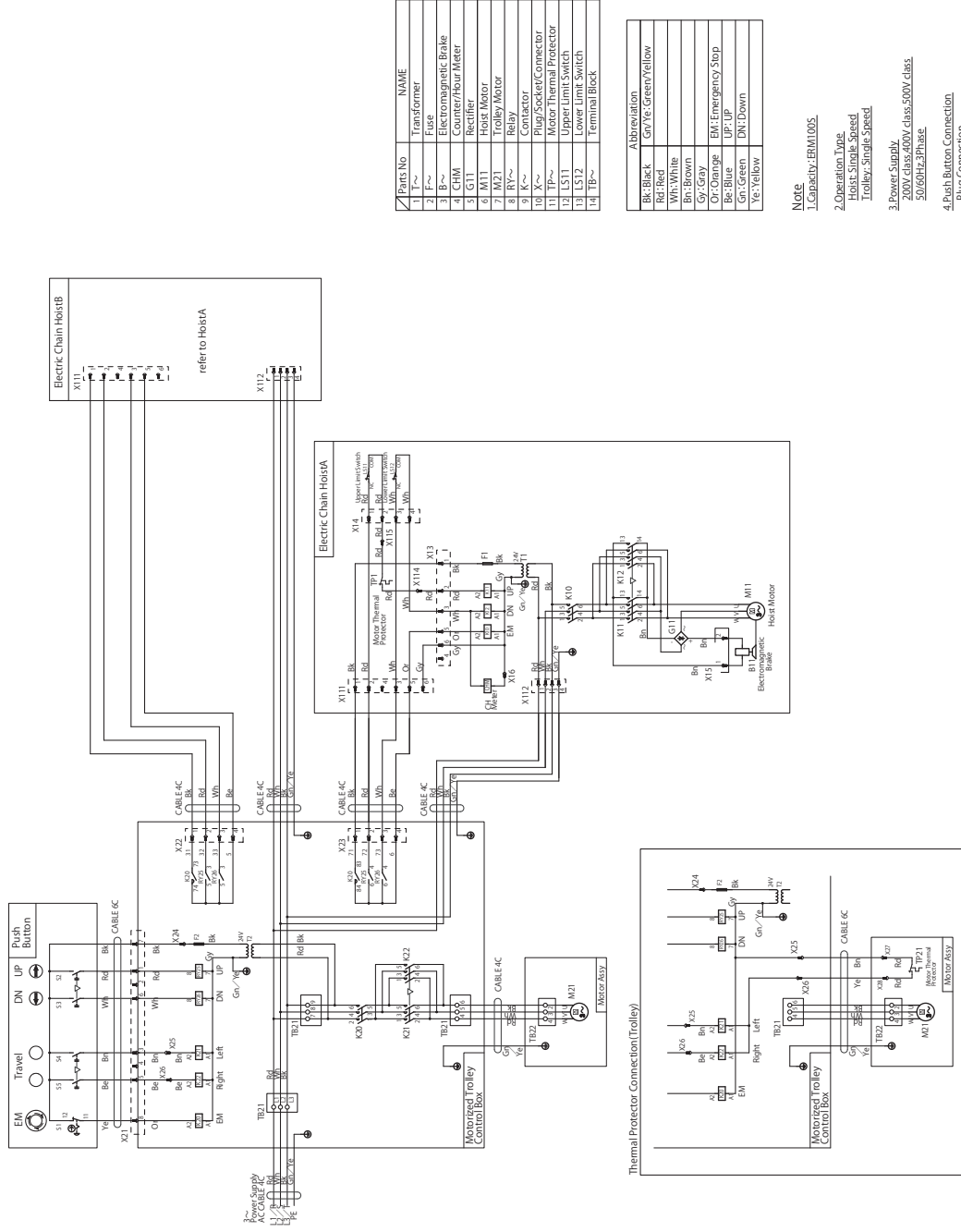

Parts No	NAME
1	Transformer
2	Fuses
3	B~
4	Electromagnetic Brake Counter/Hour Meter
5	G11 Rectifier
6	M11 Hoist Motor
7	M21 Trolley Motor
8	RY~ Relay
9	K~ Contactor
10	X~ Plug Socket/Connector
11	Motor Thermal Protector
12	TP~ Upper Limit Switch
13	TP~ Lower Limit Switch
14	TP~ Terminal Block

Abbreviation	Color
Bk	Black
Rd	Red
Wh	White
Br	Brown
Gy	Gray
Or	Orange
Bl	Blue
Gr	Green
Ye	Yellow

- NOTE**
- Capacity:ERM1005
 - Operation Type: Hoist, Single Speed, Trolley, Single Speed
 - Power Supply: 200V class, 400V class, 500V class, 50/60Hz, 3Phase
 - Push Button Connection: Pilot Connection

230/460V class (208-230V) (Plug Connection)

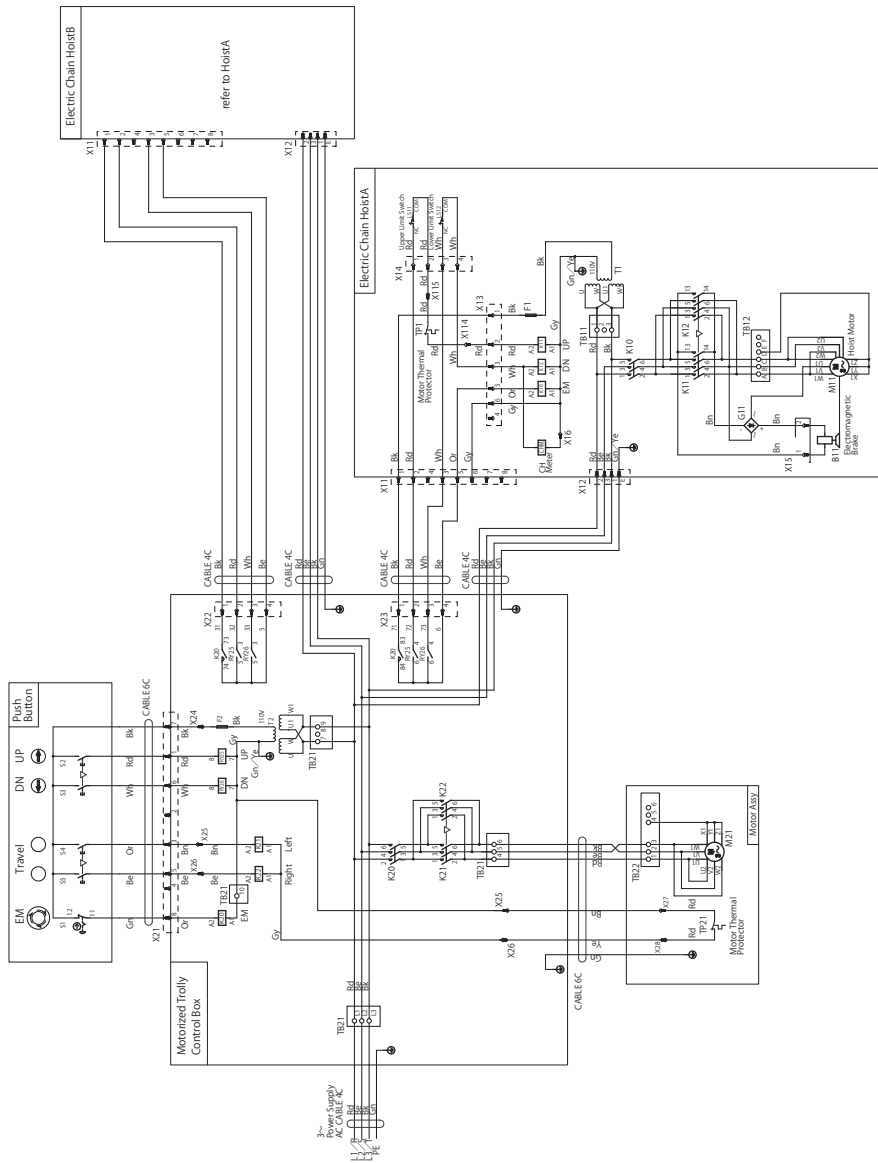

Parts No	NAME
1	Transformer
2	Fuse
3	Electromagnetic Brake
4	Counter/Hour Meter
5	Rectifier
6	Host Motor
7	Host Motor
8	Relay
9	Contactor
10	Plug/Socket/Connector
11	Motor Thermal Protector
12	Upper Limit Switch
13	Lower Limit Switch
14	Terminal Block

Abbreviation	Color
Bk	Black
Rd	Red
Wh	White
Br	Brown
Gy	Grey
Or	Orange
Bk	Blue
Gn	Green
Ye	Yellow

- Note**
- Capacity: ERM1005
 - Operation Type: Host, Single Speed, Trolley, Single Speed
 - Power Supply: 208~230V/60Hz, 3Phase
 - Push Button Connection: Plug Connection

■ 230/460V class (415-460V) (Plug Connection)

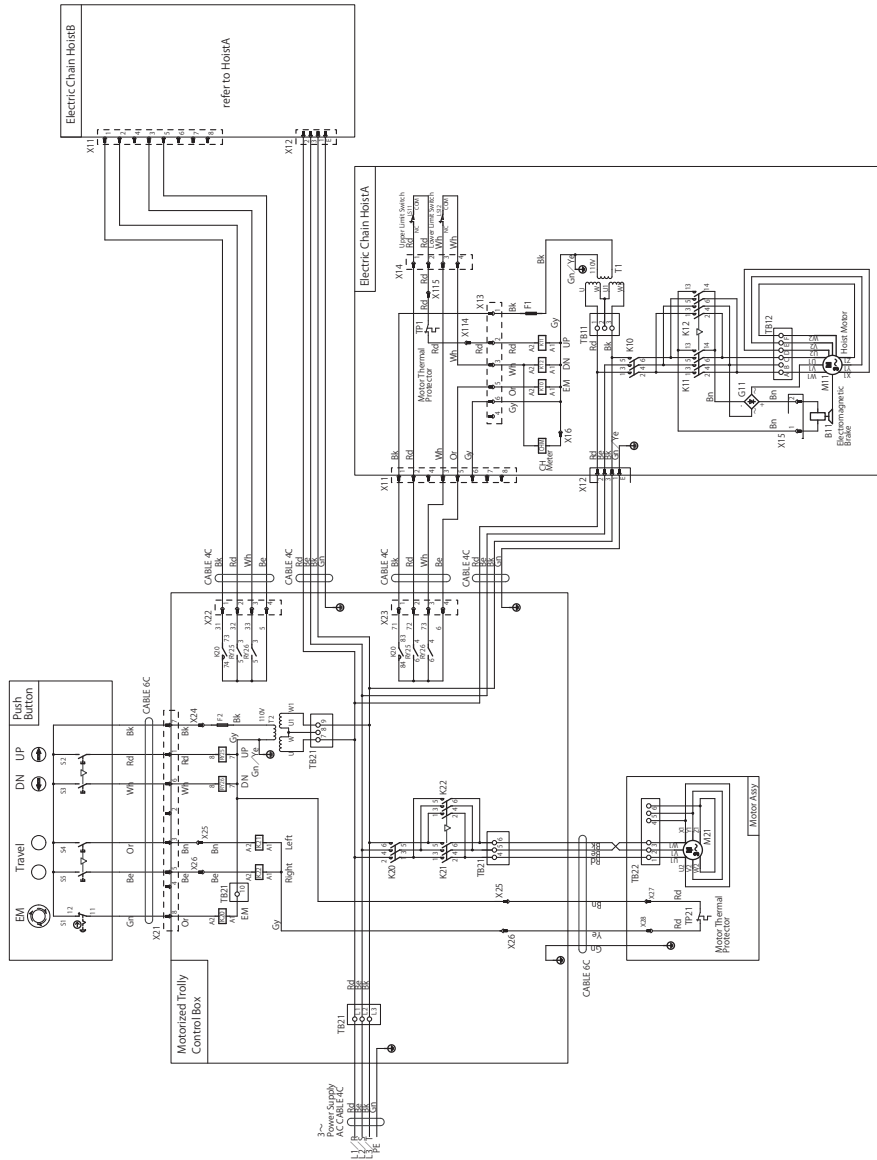

Parts No	NAME
1	T~ Transformer
2	F~ Fuse
3	B~ Electromagnetic Brake
4	CHM Counter/Hour Meter
5	G11 Rectifier
6	G12 Forwarder
7	K11 Relay Motor
8	KV~ Relay Motor
9	K~ Contactor
10	X~ Plug/Socket/Connector
11	TP~ Motor Thermal Protector
12	LS11 Upper Limit Switch
13	LS12 Lower Limit Switch
14	TB~ Terminal Block

Abbreviation	Color
Bk	Black
Rd	Red
Wh	White
Bl	Blue
Gr	Green
Or	Orange
Em	Emergency Stop
Blu	Blue
Grn	Green
Yel	Yellow

NOTE

- Capacity: ERM1005.
- Operation Type: Hoist: Single Speed, Trolley: Single-speed.
- Power Supply: 415~460V, 60Hz, 3-Phase.
- Push Button Connection: Plug Connection.

Wiring Diagram of Single Speed ERM10t

200V class, 400V class, 500V class (Plug Connection)

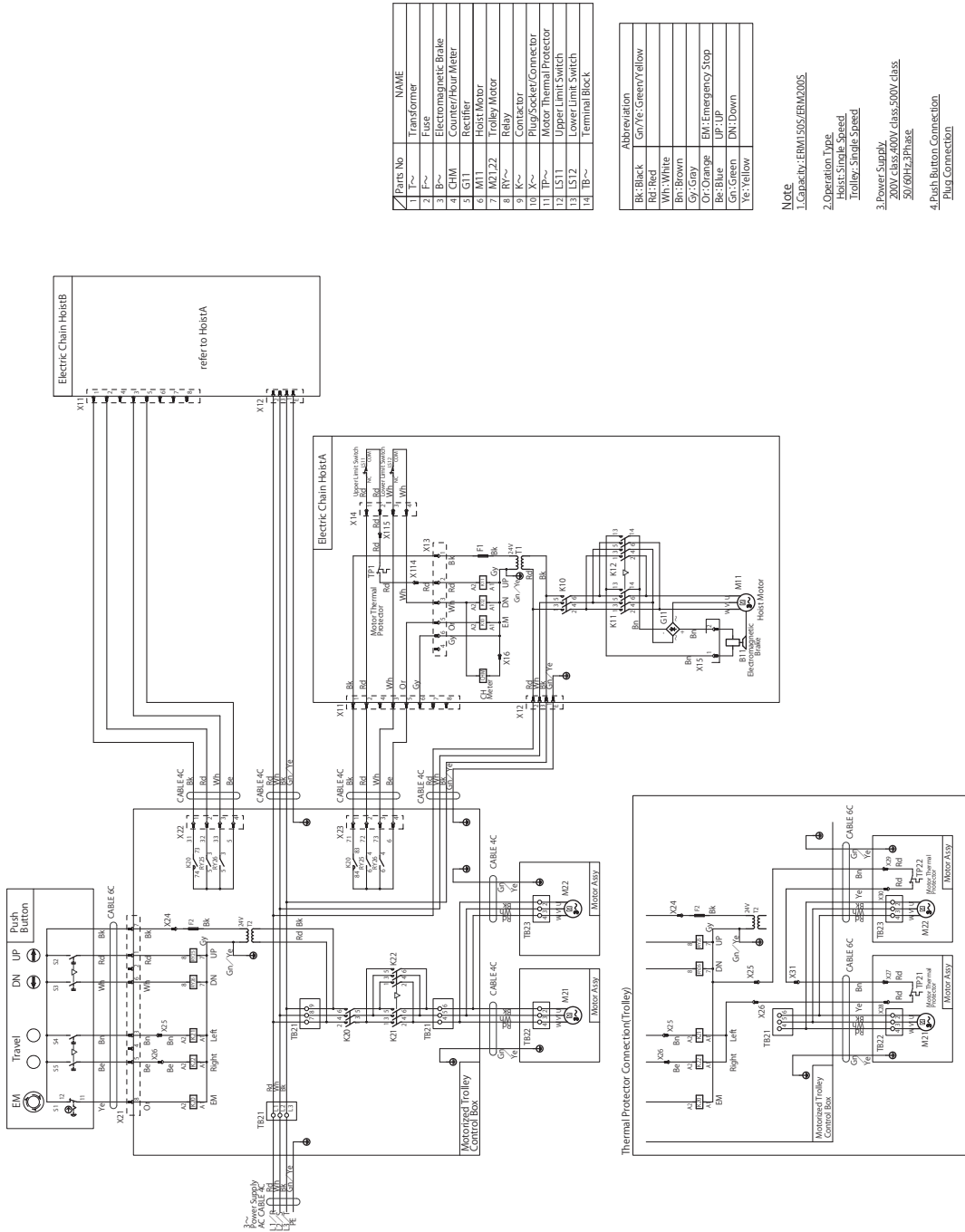

Parts No	NAME
1	Transformer
2	Fuse
3	Electromagnetic Brake
4	CHM Counter/Hour Meter
5	GM1 Rectifier
6	M11 Host Motor
7	M21,22 Trolley Motor
8	RV~ Relay
9	Contactor
10	Plug/Socket/Connector
11	TP~ Motor Thermal Protector
12	LS11 Upper Limit Switch
13	LS12 Lower Limit Switch
14	FB~ Terminal Block

Abbreviation
Bk: Black
Gr/Yl: Green/Yellow
Rd: Red
Wh: White
Brn: Brown
Gy: Grey
Or: Orange
Bz: Blue
Gr: Green
Yl: Yellow

- Note**
- Capacity: ERM150S, ERM200S.
 - Operation Type: Hoss-Single Speed, Trolley-Single Speed.
 - Power Supply: 200V class, 400V class, 500V class, 50/60Hz, 3Phase.
 - Push Button Connection: Plug Connection.

■ 200V class 400V class, 500V class (Direct Connection)

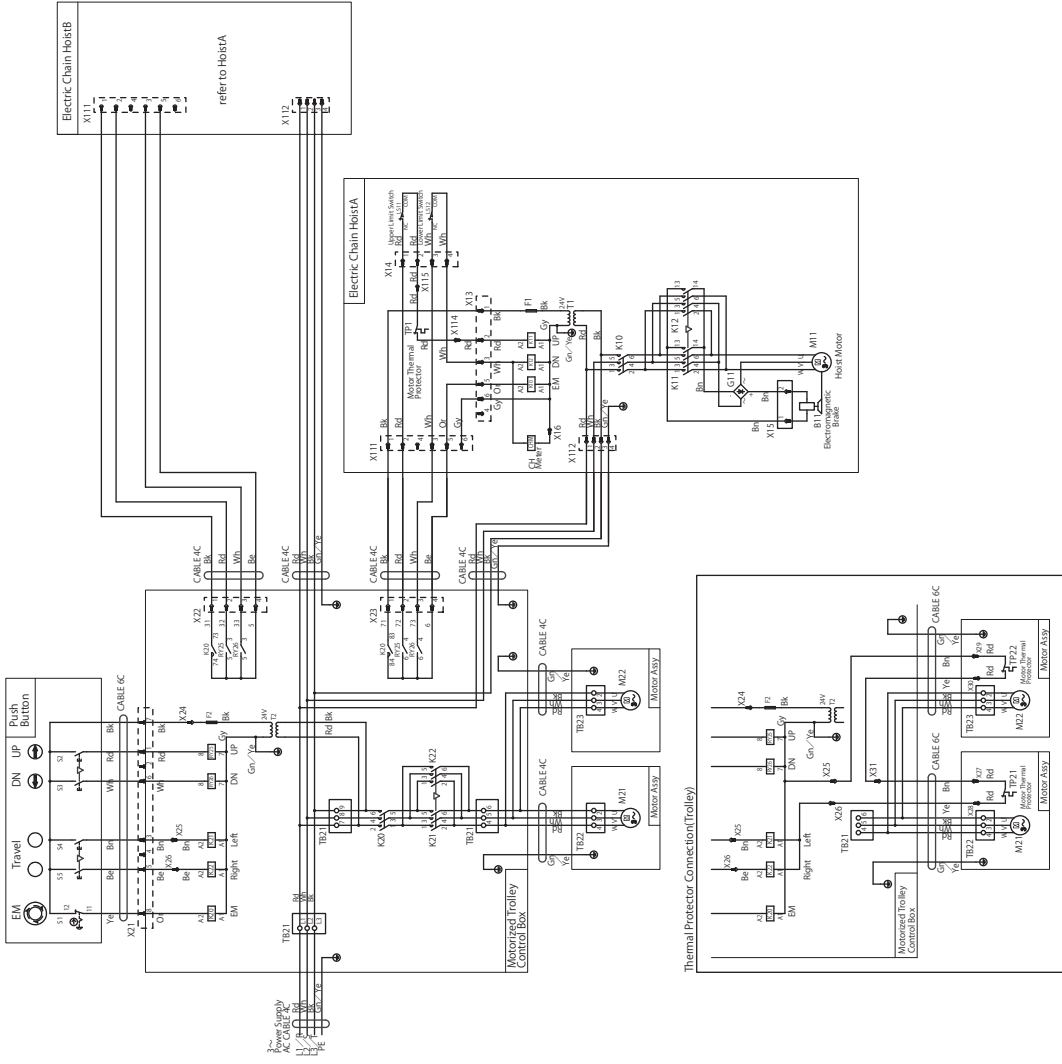

Parts No	NAME
1	Transformer
2	Fuse
3	Electromagnetic Brake
4	CHM Counter/Hour Meter
5	M11 Hoist Motor
6	M21,22 Trolley Motor
7	Relay
8	Contactor
9	Plug/Socket/Connector
10	Motor Thermal Protector
11	Upper Limit Switch
12	LS11 Lower Limit Switch
13	LS12 Terminal Block
14	Terminal Block

Abbreviation	Color
Bk	Black
Gr	Green
Yl	Yellow
Wh	White
Br	Brown
Gr	Gray
Or	Orange
Bl	Blue
Gn	Green
Ye	Yellow

- Note**
1. Capacity: EMI1505/EM2005.
 2. Operation Type: Hoist, Single Speed, Trolley, Single Speed.
 3. Power Supply: 200V class, 400V class, 500V class, 50/60Hz, 3Phase.
 4. Push Button Connection: Plug Connection.

230/460V class (208-230V) (Plug Connection)

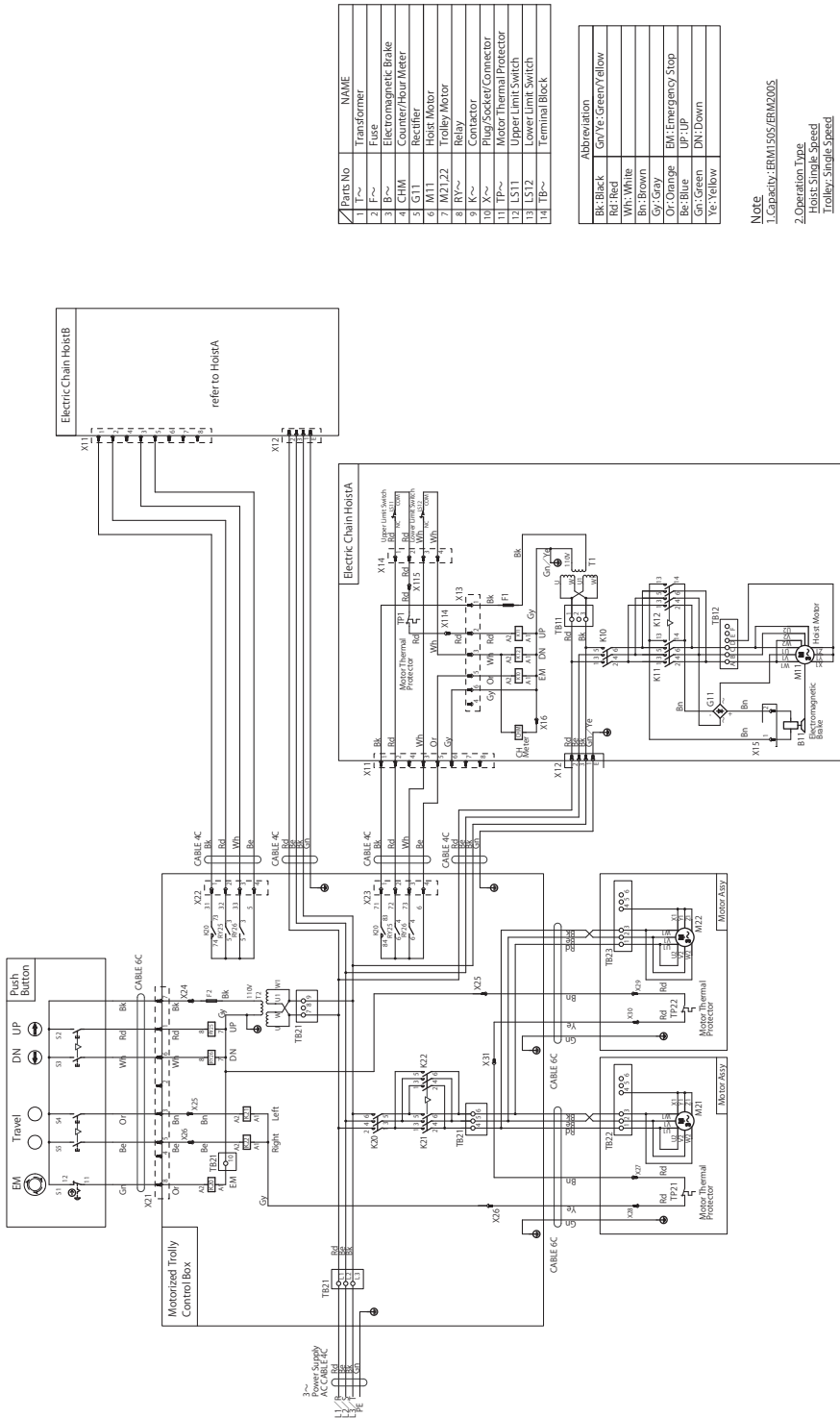

Parts No	NAME
1 T~	Transformer
2 F~	Fuse
3 B~	Electromagnetic Brake
4 CHM	Counter/Hour Meter
5 G11	Rectifier
6 MT1	Hoist Motor
7 R02122	Trolley Motor
8 K~	Relay
9 K~	Relay
10 X~	Plug Socket/Connector
11 TP~	Motor Thermal Protector
12 LS11	Upper Limit Switch
13 LS12	Lower Limit Switch
14 TB~	Terminal Block

Abbreviation	Color
Bk	Black
R	Red
Wh	White
Br	Brown
G	Green
B	Blue
Gr	Green
Y	Yellow

- Note**
- Capacity: ERM150/ERM205
 - Operation Type: Hoist Single Speed, Trolley Single Speed
 - Power Supply: 208~230V/3Phase
 - Plug Burton Connection: Plug Connection

■ 230/460V class (415-460V) (Plug Connection)

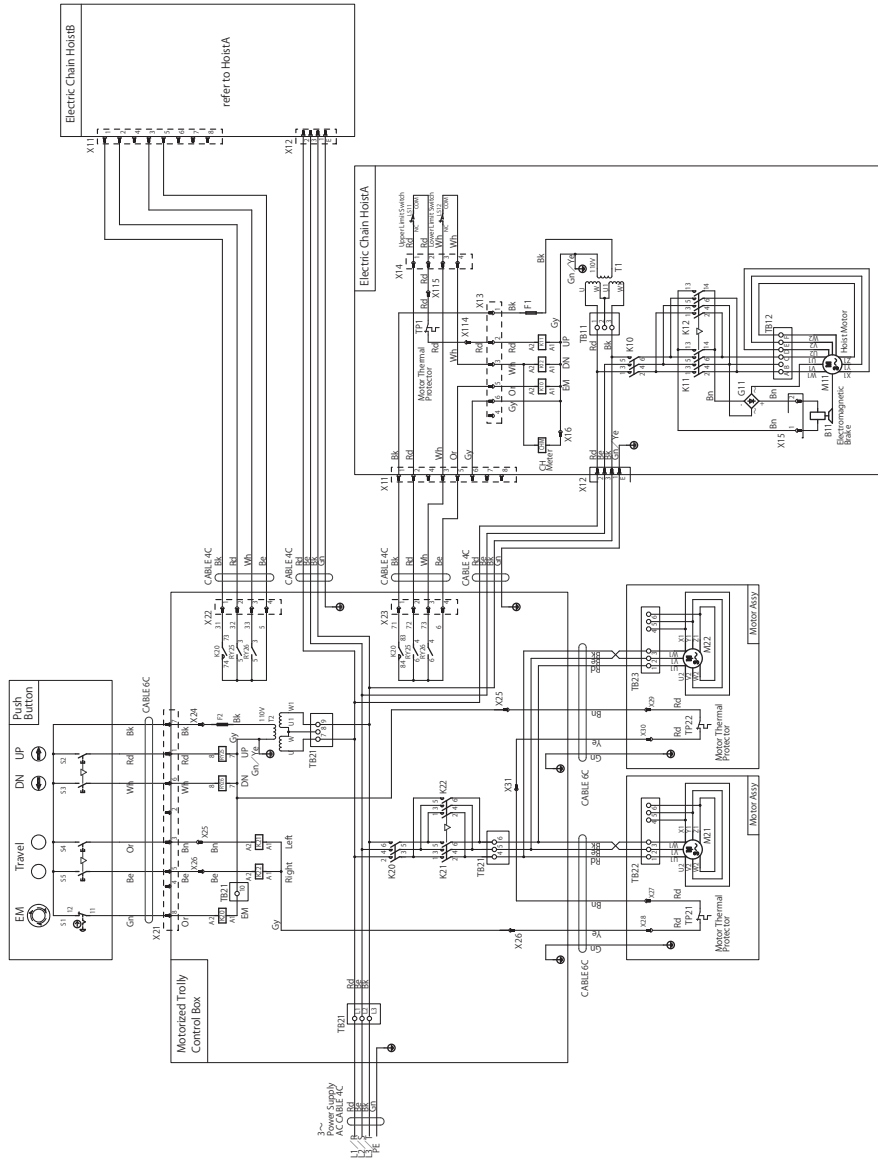

Parts No	NAME
1	T~ Transformer
2	F~ Fuse
3	B~ Electromagnetic Brake
4	CHM Counter/Hour/Meter
5	CHM Counter/Hour/Meter
6	CHM Counter/Hour/Meter
7	M21, 22 Trolley/Motor
8	RY~ Relay
9	K~ Contactor
10	X~ Plug/Socket/Connector
11	TP~ Motor Thermal Protector
12	LS11 Upper Limit Switch
13	LS12 Lower Limit Switch
14	TB~ Terminal Block

Abbreviation	Color
Bk	Black
Gr	Green
Ye	Yellow
Wh	White
Bl	Blue
Br	Brown
Gy	Grey
Or	Orange
Be	Blue
Gr	Green
Ye	Yellow

- NOTE**
1. Cable: ERM150S/ERM200S.
 2. Operation Type:
 - Logic: Single-Speed
 - Trolley: Single-Speed
 3. Power Supply: 415~460V/60Hz, 3Phase
 4. Push Button: Connection Plug Connection

< Memo >

A series of horizontal dotted lines for writing.



KITO

Global Website: kito.com