

TCS Series Air Hoist (250 kg to 980 kg)

Instruction Manual

**Hook Suspended Type,
Manual Trolley Type**
TCSH03CS/PS
TCSH04CS/PS
TCSH09CD/PD
TCSH09CS/PS

To Customer

- Thank you for purchasing KITO Air Hoist (TCR Series).
- Operators and maintenance engineers are requested to read this manual.
- After reading, please keep this manual at hand for future use.
- This product is designed considering the environment protection. The product contains none of six hazardous substances specified by European RoHS Directives nor asbestos.

Table of Contents

Introduction	3	Operation	33
Disclaimer	3	Operating the Cord and Pendant	35
Restriction on Use	3	Precautions for Operation	38
Warning Indication	4	Maintenance	41
General Matters on Handling and Control	5	Daily Inspection	41
Opening the Package	6	Frequently inspection	47
Checking the Product	6	Periodic Inspection	50
Recording the Product No.	6	Check Sheet for daily inspection	52
Recording the Hook Dimensions	7	Check Sheet for Frequent inspection	54
Checking the Mark on the Load Chain	7	Warranty	56
Product Components	8			
Hook Suspended Type	8			
Manual Trolley Type	10			
Product Specification and Operational Environment	11			
Product Specification	11			
Operational Environment	12			
Preparations before Daily Work	13			
Selecting the Compressor and Removing the Drain	13			
Piping	13			
Preparing and Attaching the Air Supply Hose	14			
Lubrication	17			
Exhaust Piping	17			
Checking the Product Components	18			
Attaching the Chain Container	20			
Attaching the Upper Accessory	21			
Combining with the Trolley and Adjusting the Applicable Rail Width	26			
Installing the Product	28			
Checking after Installation	31			
Adjusting the Maximum Speed	32			

Introduction

Thank you for purchasing KITO Air Hoist (TCS Series).

The Air Hoist (TCS Series) is designed and manufactured for the purpose of lifting and lowering a load vertically, powered by compressed air, within a normal environment. The manual trolley are designed and manufactured for the purpose of moving the lifted load laterally in combination with the air hoist.

The instruction manual is intended for the actual operators and maintenance engineers of the air hoist. When using the air hoist, fully understand the instruction manual together with the instruction manual for the compressor.

■ Disclaimer

- KITO shall not be liable for any damage incurred thereof due to natural disaster such as fire, earth quake and thunderbolt, conduct by third party, accident, willful conduct or negligence by customer, erroneous use and other use exceeding the operational condition.
- KITO shall not be liable for any incidental damage due to the use or non-use of the product such as loss of business profit, suspension of business and damage of the lifted load.
- KITO shall not be liable for any damage arising from negligence of the contents in the instruction manual and the use of the product exceeding the scope of its specification.
- KITO shall not be liable for any damage arising from the malfunction due to the combination of the product with other devices in which KITO is not concerned.
- KITO shall be indemnified from any loss of life, bodily injury and property damage due to the use of our product for which it has been 10 years since its delivery.
- KITO shall not be liable to supply the spare parts for the product for which it has been 15 years since the discontinuation of the product.

■ Restriction on Use

- The product is intended for use only in the region or the country where it was purchased. Due to the differences in regulations and standards, it is not for use outside of the region or the country where it was purchased.
- The product described herein is not designed or manufactured for transporting people. Do not use the product for that purpose.
- The product described herein is designed for the materials handling work such as lifting/lowering and traveling the load under ordinary operational condition. Do not use the product for the work other than materials handling work.
- Do not assemble the product into machinery not for materials handling, as a part of it.

■ Warning Indication

Improper use of air hoist causes danger such as drop of lifted load. Read this instruction manual carefully before installation, operation and maintenance. Use the product after understanding the product knowledge, safety information and precautions.

This instruction manual classifies the safety information and precautions into three categories of “DANGER”, “WARNING” and “CAUTION”.

Description of Signal Words

 **DANGER** Indicates an imminently hazardous situation which, if not avoided, will result in death or serious injury.



 **WARNING** Indicates a potentially hazardous situation which, if not avoided, could result in death or serious injury.



 **CAUTION** Indicates an imminently hazardous situation which, if not avoided, may result in minor or moderate injury. It may also be used to alert against unsafe practices.

Further, the event described in CAUTION may result in serious accident depending on the situation. Both DANGER and CAUTION describe important contents. Please follow the instruction.

After reading, please keep this manual at hand for future use by the user.

Description of Safety Symbols

 Means “Prohibited” or “You must not do”.
Prohibited action is shown in the circle or described near the circle.
This instruction manual uses  as the general prohibition.

 Means “Mandatory Action” or “You must do”.
Required action is shown in the circle or described near the circle.
This instruction manual uses  as the general instruction.

■ General Matters on Handling and Control

WARNING



Prohibited

Only the personnel with expertise and know-how should be allowed to disassemble and repair the air hoist.
Do not modify the product and its accessories.

Failure to comply with these instructions may not only fail to exert the successful functions and performance of the air hoist, but cause unexpected trouble, resulting in a grave accident.



Mandatory

Understand the contents of the instruction manual sufficiently. Then operate the air hoist.
Use the product according to the instructions on the warning labels or the tags pasted to its different parts.

Improper use of the air hoist may not only fail to exert its successful functions and performance of the air hoist, but hinder safe operations, resulting in a grave accident.

CAUTION



Prohibited

When transporting the product, care should be taken not to drag, hit against an object or drop it.

Failure to comply with this instruction not only fail to exert the successful functions and performance of the air hoist due to damage on or air leak from the air hoist, but cause a grave accident.



Mandatory

Prior to using the air hoist, conduct daily inspection.
Contact our office or our dealer for periodic inspection, repair of the air hoist and maintenance.
Keep regular (frequent and periodic) inspection records.

Failure to comply with inspection and maintenance may not only fail to exert the successful functions and performance of the air hoist, but cause a grave accident.

NOTE

When discarding the product, disassemble it to an extent that it cannot be reused, and follow the local municipal ordinance or the rules specified by the business operator.

Opening the Package

■ Checking the Product

- Make sure that the indications on the package and the packed product coincide with your order.
 - Make sure that the code indicated on the package label or the nameplate of the product body conforms to the ordered product.
 - The package includes the following items in addition to the hoist body.



Instruction manual



Test report



Load chain grease tube



Plastic or canvas chain container



horse stem

- If the manual trolley (TSP) to be combined with the air hoist has been ordered at the same time, note that it will be delivered in a separate package.

(Separate package)



(TSP)

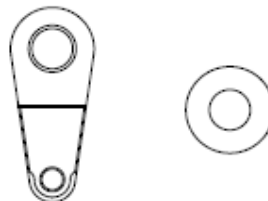

(Trolley combining parts: Suspender, collar, etc.)

- Make sure that the product has not been deformed or damaged due to vibrations, load shift, etc. during transportation.

■ Checking the Product No.

- Enter the product code, serial number, date of purchase and name of the sales shop inscribed on the nameplate attached to the product in the following table.
- * When you ask for repair or order expendable parts, let us know these information as well.

Item	Product information
Product type (Code)	
Serial No.	
Date of purchase	
Name of the sales shop	

■ Recording the Hook Dimensions

At the time of unpacking, enter the dimension L between the embossed marks of the hook and the hook thickness dimension H in the following table for maintenance reason.

(These numerical values are used for inspection.)

Dimension	Bottom hook
L	(mm)
H	(mm)

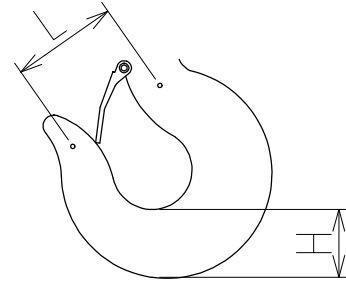

■ Checking the Marks on the Load Chain

Type marks are indicated on the load chain at equal pitches.

Seeing the following table, check that your product code is compatible with the indicated marks and load chain size.

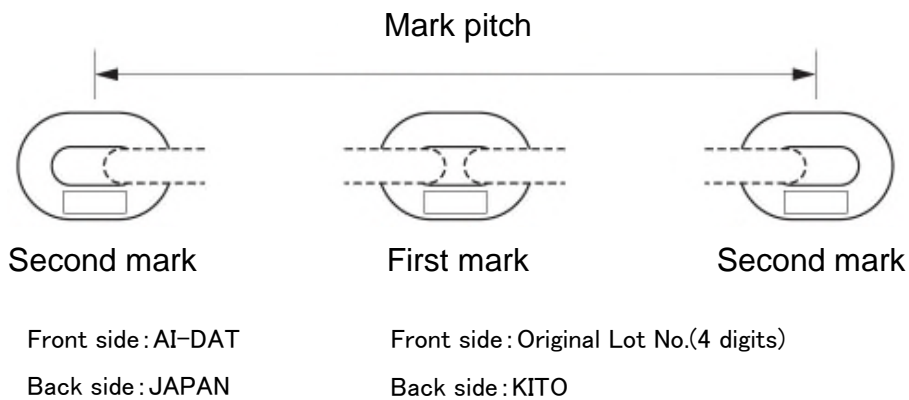

Product code	Load Chain size: diameter (mm)	Mark pitch	First mark (Front side/Back side)	Second mark (Front side/Back side)
TCSH03CS/PS, TCSH04CS/PS TCSH09CD/PD	6.3	20 Links	4 digits /KITO	AI-DAT/JAPAN

Product Components

■ Hook Suspended Type

■ 250 kg - 490 kg (TCSH03CS/PS, TCSH04CS/PS)

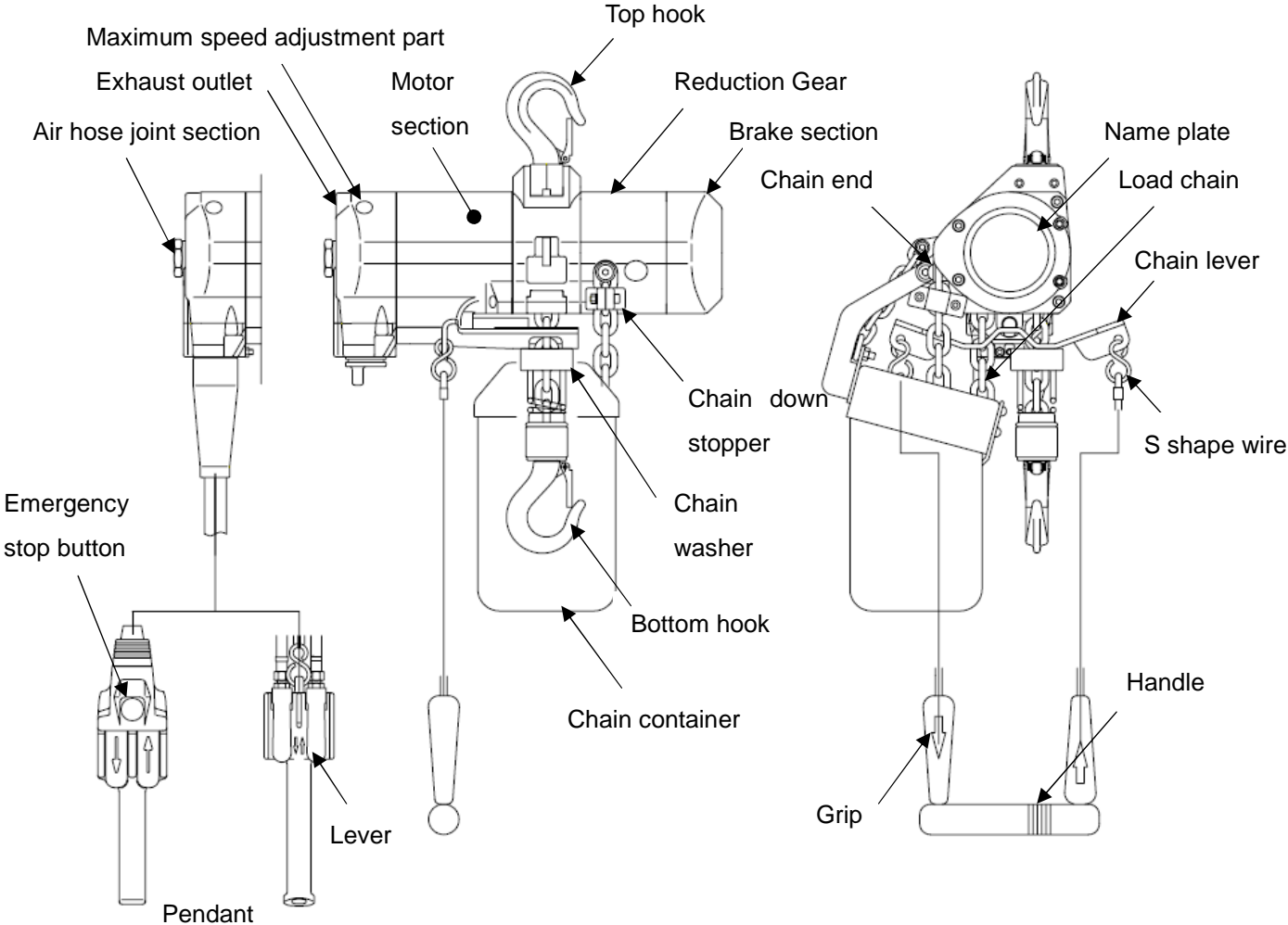

■ 980 kg (TCSH09CD/PD)

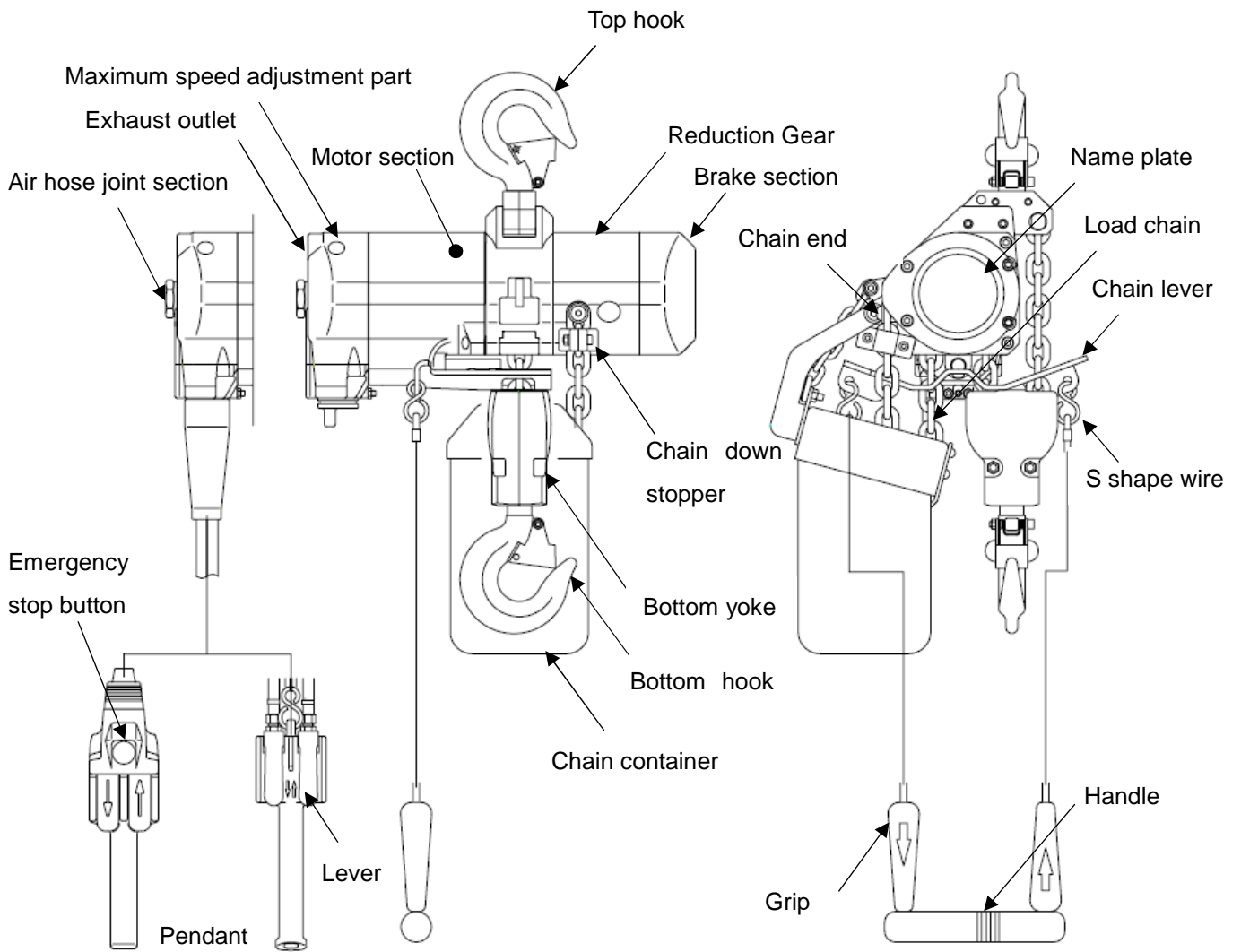

■ Manual trolley type

■ Plain trolley (TSP) type

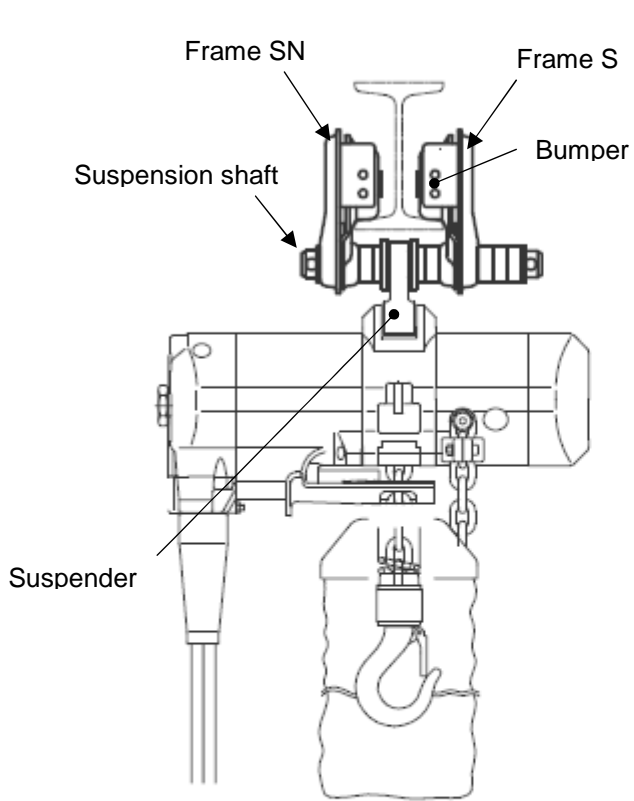

※Refer to page 8-9 for the Air Hoist parts name.

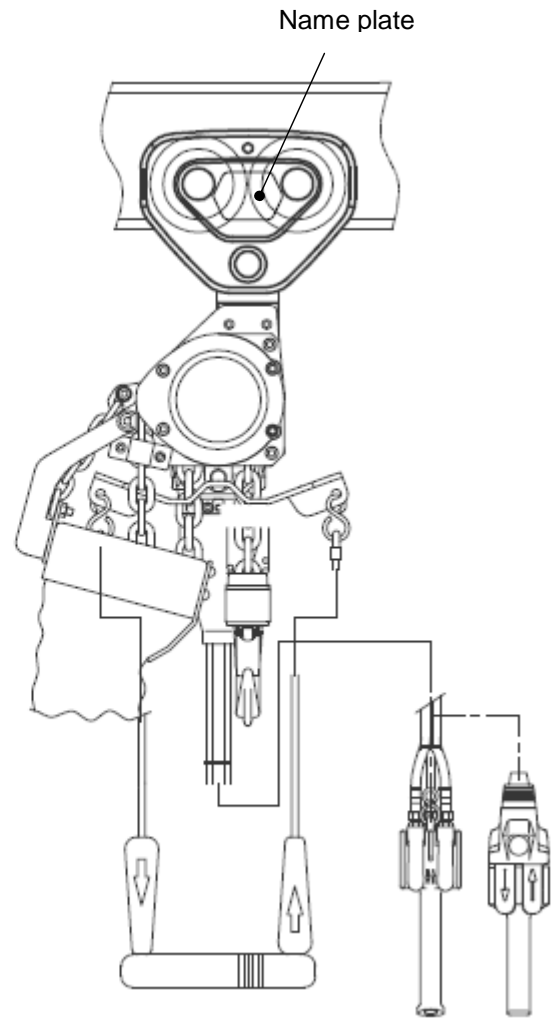

Product Specification and Operational Environment

■ Product Specification

■ Common specification

Service air pressure: 0.4 to 0.6 MPa

Color: KITO Yellow (Equivalent to Munsell 7.2YR6.5/14.5)

Noise level: 85±3 dB(A)

Brake capacity: 400% or more (when the rated load is applied)

■ Hook suspended type (Single unit hoist)

Capacity	Code	Lift (m)	Operation method	Load chain diameter(mm) xNo. of falls	Speed (m/min)				Air consumption (m ³ /min)	Air inlet (Rc)	Net weight (kg)
					During rated loading		When unloaded				
					Lifting	Lowering	Lifting	Lowering			
250kg	TCSH03CS	3	Pendant	φ6.3x1	34.0	63.0	63.0	38.0	2.1	1/2	20
250kg	TCSH03PS	3	Cord	φ6.3x1	34.0	63.0	63.0	38.0	2.1	1/2	21
490kg	TCSH04CS	3	Pendant	φ6.3x1	17.0	33.0	33.0	19.0	2.1	1/2	20
490kg	TCSH04PS	3	Cord	φ6.3x1	17.0	33.0	33.0	19.0	2.1	1/2	21
980kg	TCSH09CD	3	Pendant	φ6.3x2	8.5	17.0	16.5	9.5	2.1	1/2	26
980kg	TCSH09PD	3	Cord	φ6.3x2	8.5	17.0	16.5	9.5	2.1	1/2	27

* The performance values in the table above are when the service air pressure is 0.6 MPa and the pendant hose length is 2 m; the values in the table differ in other cases.

■ Manual trolley type

■ Plain Trolley Combination Type

Capacity	Code	Lift (m)	Operation method	Load chain diameter(mm) x No. of falls	Speed (m/min)				Air consumption (m ³ /min)	Applicable rail width (mm)	Minimum turning radius (mm)	Air inlet (Rc)
					During rated loading		When unloaded					
					Lifting	Lowering	Lifting	Lowering				
250kg	TCSH03CS	3	Cord	φ6.3x1	34.0	63.0	63.0	38.0	2.1	[50],75,100	1100	1/2
250kg	TCSH03PS	3	Pendant	φ6.3x1	34.0	63.0	63.0	38.0	2.1	[50],75,100	1100	1/2
490kg	TCSH04CS	3	Cord	φ6.3x1	17.0	33.0	33.0	19.0	2.1	[50],75,100	1100	1/2
490kg	TCSH04PS	3	Pendant	φ6.3x1	17.0	33.0	33.0	19.0	2.1	[50],75,100	1100	1/2
980kg	TCSH09CD	3	Pendant	φ6.3x2	8.5	17.0	16.5	9.5	2.1	75,100,125	1300	1/2
980kg	TCSH09PD	3	Cord	φ6.3x2	8.5	17.0	16.5	9.5	2.1	75,100,125	1300	1/2

* The performance values in the table above are when the service air pressure is 0.6 MPa and the pendant hose length is 2 m; the values in the table differ in other cases.

When the applicable rail width numerical value is shown in square brackets [], only straight rails can be used.

■ Operational Environment

Installation site: Indoor

Ambient temperature: -10°C to 60°C

Humidity: 85%RH

Operating atmosphere:

Place free from oil mist, corrosive gas, flammable gas, explosive gas, volatile gas and steam.

Do not operate the product in the places exposed to an organic solvent, much powder dust, much acid and salinity, and direct sunshine.

* When the Product is used in a special environment, consult us.

CAUTION



Prohibited

An air motor lubricant is slightly discharged from the air hoist body because of the structural reason of the air hoist. Do not use in an environment accepting no oils and fats.

The discharged lubricant may damage your properties or result in an accident affecting the health of your body such as falling.

Preparations before Daily Work

■ Selecting the Compressor and Removing the Drain

■ Guide for selection

(For max air consumption of each air hoist, see the specifications on Page 13,14)

$$(\text{Max air consumption} \times 10) \times \text{No. of units used} \leq \text{Compressor horsepower}$$

■ Removing the drain

Internal accumulation of water and oil causes rust and trouble. Before and after daily work, loosen the drain valve at the lower part of the air tank of the compressor to remove internally accumulated water and oil so as to use dry clean compressed air. (For details, see the instruction manual for the compressor.)

■ Piping

See the following piping diagram to connect pipes. The customer is requested to prepare the devices and materials enclosed by dotted lines in the piping diagram.

Main and branch pipes should be larger than the hose size, and use as large as possible ones. If they are smaller or too long, full performance may not be exhibited due to pressure loss.

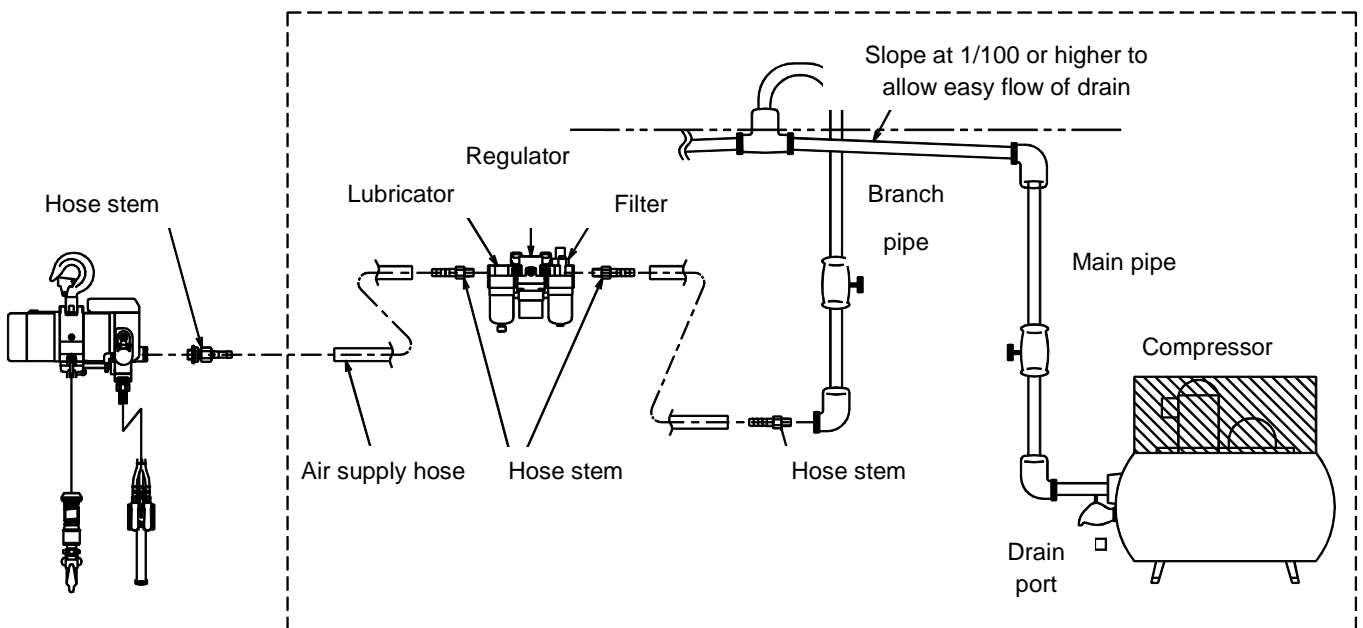

(Piping diagram)

⚠ CAUTION



Mandatory

Be sure to install an air filter, reducing valve and lubricator (line oiler) near the air hoist. The air filter, reducing valve and lubricator (line oiler) should be sized larger than the hoses.

Improper air control may not only cause trouble and malfunctioning due to rust, early wear of internal parts, but lead to bodily injury due to these factors.

Use the air filter, regulator and lubricator larger than the hose size.



The pilot type regulator is recommended. If the regulator is not the pilot type, it is recommended to use the regulator one size above in order to secure the performance.

For handling of the air filter, regulator and lubricator, follow the instructions in the manufacturer's instruction manual.

(Recommended air set)

Target product type	Air set	Type	Manufacturer
TCSH03CS/PS	Regulator	AR625-06G	SMC Corporation
TCRH04CS/PS	Filter	AF50-06-A	
TCRH09CD/PD	Lubricator	AL50-06-A	

It is recommended to use the regulator with pressure gauge in order to check the air pressure. Also, use a mounting bracket as required.

 CAUTION	
 Prohibited	<p>Do not use quick couplers to connect the hoses and pipes.</p> <p>Failure to comply with this instruction may not only fail to exert the successful functions and performance of the air hoist, but cause troubles, leading to an unexpected accident.</p>

■ Preparing and Attaching the Air Supply Hose

■ Air hose inner diameter

- Check the purchased product type and prepare the hose with inner diameter shown in the table below.
- Also, prepare hose bands suitable for the hose used.

Code	Unit (mm)					
	TCSH03CS	TCSH03PS	TCSH04CS	TCSH04PS	TCSH09CD	TCSH09PD
Hook suspended type/ Manual trolley type	12.7 or more					

(Recommended air supply hoses)

Hose inner diameter (mm)	Manufacturer	Type	Use pressure (Mpa)
12.7	The Yokohama Rubber Co., Ltd.	HI-MID Oil Series HI-MID12	0-1.5
19		HI-MID Oil Series HI-MID19	0-1
25		HI-MID Oil Series HI-MID25	0-1

■ Air hose length

⚠ CAUTION



Mandatory

The air hose length used should be within 10 m.

Taking account of pressure loss according to the length of the air supply hose, adjust the air pressure with the regulator and use at the appropriate service air pressure (0.4 to 0.6 MPa; 0.6 MPa recommended).

Failure to adjust the service air pressure not only fails to exert successful functions and performance of the air hoist, but obstructs efficient operation.

See the following table for relations between an air flow rate and a pressure drop when the hose is 10 m long.

Hose dimension (mm)	Hose inlet pressure (MPa)	Free air flow rate through 10-m hose(m ³ /min)							
		0.5	0.75	1	1.25	1.5	2	2.5	3
		Pressure drop (MPa)							
9.5 (10)	0.4	0.0439	0.0987	0.1757	0.2549				
	0.5	0.0382	0.0879	0.1461	0.227	0.3306			
	0.6	0.0328	0.074	0.1326	0.1971	0.2835			
	0.7	0.0294	0.0626	0.1155	0.1732	0.2492			
12.7	0.4	0.0107	0.0249	0.0424	0.0648	0.0932			
	0.5	0.0091	0.0203	0.036	0.0541	0.078			
	0.6	0.0078	0.0173	0.0309	0.0464	0.0668	0.1184	0.1849	
	0.7	0.0071	0.0155	0.0269	0.0424	0.0588	0.0999	0.1561	
19.0	0.4	0.0001	0.0033	0.0057	0.0089	0.0124	0.022	0.0346	0.0459
	0.5	0.0001	0.0028	0.0047	0.0075	0.0108	0.0184	0.0288	0.0415
	0.6	0.0001	0.0025	0.0041	0.0065	0.0093	0.0159	0.0248	0.0355
	0.7		0.0016	0.0036	0.0043	0.0081	0.0144	0.0217	0.0312

* When the hose is longer than 10 m, there are proportional relations between the hose length and a pressure loss. If the hose length is 20 m, for instance, its pressure loss is twice higher than the pressure loss value in the table.

■ Adjusting the service air pressure

In order to maintain the performance of the air hoist, supply the appropriate service air pressure (0.4 to 0.6 MPa; 0.6 MPa recommended), taking account of pressure loss in the air supply hose connecting the air set (regulator, air filter and lubricator) and the air hoist.

■ Adjusting the pressure loss and service air pressure

Example: When using the TCSH03CS (250 kg) with the 10 m long air supply hose

- (1) The hose inner diameter is 12.7 mm according to the table on Page 14.
- (2) The maximum air consumption is 2.1 m³/min. according to the specification table on Page 11.
(When the table has no relevant air consumption for the maximum air consumption value of the Product, take the closest higher value.)
- (3) The pressure loss is 0.1849 MPa according to the table above, based on the hose inner diameter, hose inlet pressure (when the regulator's pressure gauge indicates 0.6 MPa) and air consumption value.

(4) Since the air pressure supplied to the air hoist is reduced only by 0.1849 MPa, the supply pressure is 0.4151 MPa (= 0.6 – 0.1849).

Adjust this reduced pressure portion finely with the regulator so as to obtain the recommended value of 0.6 MPa.

Note) Check the pressure resistance performance of the regulator and hose to adjust the supply pressure.

■ Attaching the Air Hose to the Air Hose Joint

⚠ CAUTION



Mandatory

Attach the air supply hose firmly to a hose stem with a hose band.

Loose connection or air leak may not only fail to exert the successful functions and performance, but detach the hose during operation, coming into contact with the worker and resulting in bodily injury.

- (1) Coil the seal tape around the threaded part of the hose nipple. Assemble the hose nipple, hose stem and hose nut as illustrated in the following figure, and attach them to the air hoist body.

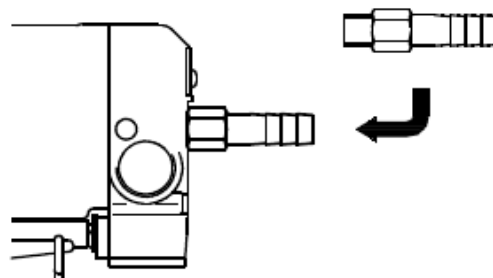
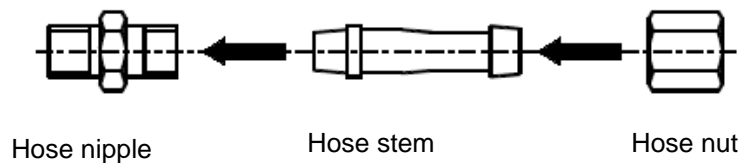

- (2) Then, insert the air hose close to the hexagonal part of the hose stem and fix it firmly with a hose band. When this is done, apply 10 drops of lubricant (see the following table) to the hose inserting part.

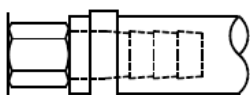
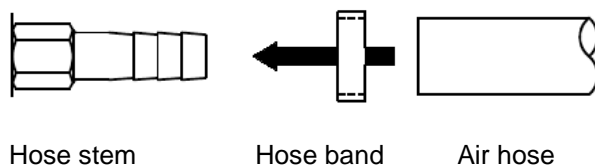

(Attachment end status)

■ Lubrication

⚠ CAUTION



Mandatory

Be sure to apply a lubricant to the load chain.

To lubricate the motor, use a lubricator (line oiler) to apply 10 to 15 drips (2 to 3 cc) of lubricant per minute.

When storing the air hoist for a long period or when using it again after long-term storage, lubricate 2 to 3 cc from the air supply hose joint, perform low-speed operation to accustom, and then, store or use it again.

Use only the specified lubricants.

Improper lubrication may not only cause trouble and malfunctioning due to rust, early wear of internal parts, but lead to bodily injury due to these factors.

(Lubricants)

Lubricant	Grade or Manufacturer	Lubricating spot	Lubrication method
EPNOC GREASE AP (N) 0	JX Nippon Oil & Energy Corporation	Load chain	Direct application
Additive turbine oil	ISOVG32-56	Air motor	Lubricator

■ Exhaust Piping

The exhaust discharged from the air hoist motor contains a slight amount of lubricant.

This exhaust can be discharged outdoors or to another place by the following method.

- (1) Remove the exhaust plate and silencer.
- (2) Connect discharge piping to the internal NPT3/4 female threads.

The inner diameter of the exhaust piping should be 3/4 (19 mm) near the connection to this product (within approx. 100 mm from this product) and upsize the inner diameter of the subsequent piping and hose to 1 inch (25 mm) or more

Note that if the smaller size of piping is connected, the performance degrades.

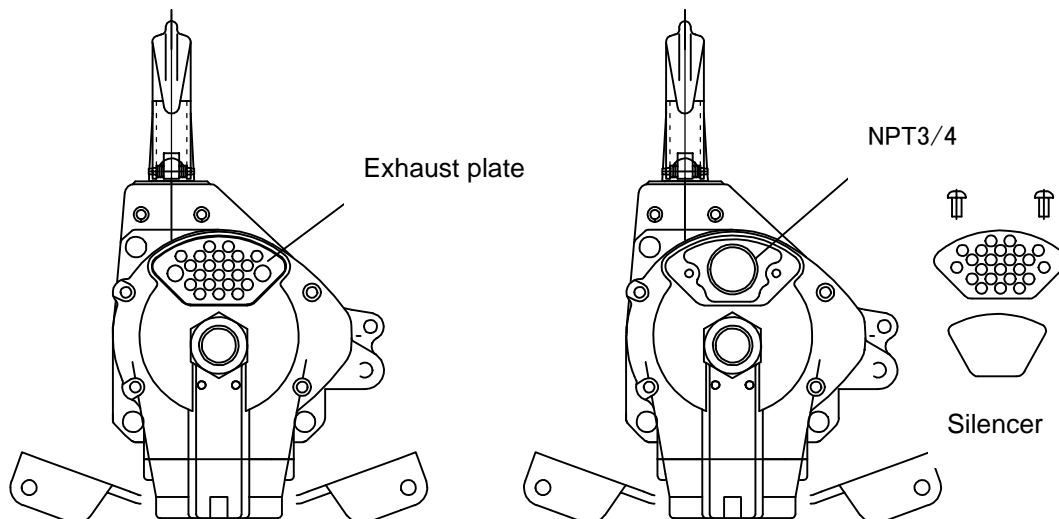

■ Checking the Product Components

■ Checking the chain end connection

- Check that the end of the chain is firmly attached to the hoist body with a hexagon socket button head screw (M8 x 15) and a plain washer (ø8).

Retighten the screw or bolt, if loosened.

Tightening torque = 12 N·m

- Check that the chain is free from torsion at the chain fixing part, and that the weld zone of the vertical link is directed as illustrated in the following figure.

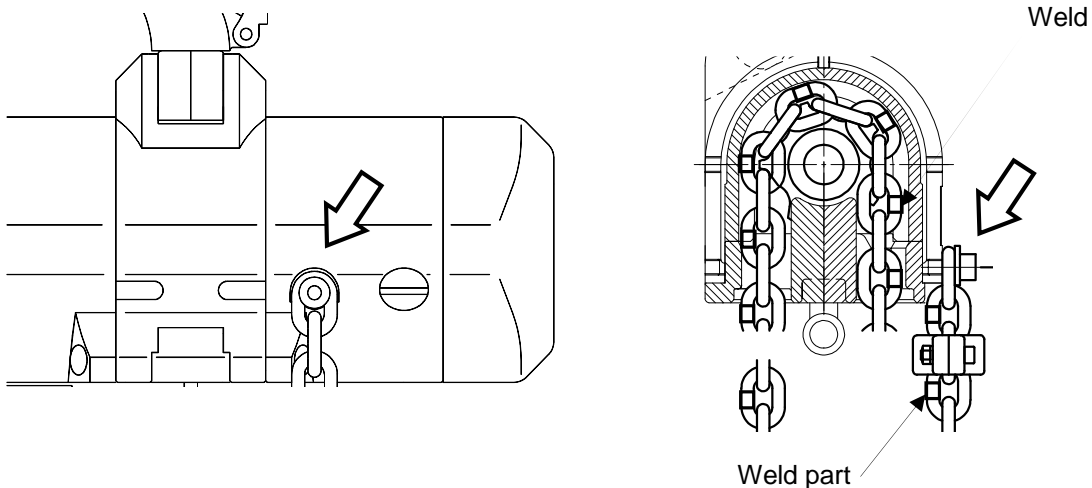

(250kg-980kg)

■ Checking the chain-down stopper (other than 250kg)

⚠ WARNING



Mandatory

Be sure to attach a chain-down stopper to the specified position.

If it is not attached, the chain may come off when an overwinding prevention device is not activated by any chance, resulting in death or a grave accident due to a fall of the suspended load.

If it is attached to other than the specified position, the overwinding prevention device fails to function successfully, resulting in hoist trouble.

- Check that the chain-down stopper has been attached to the position illustrated in the following figure.

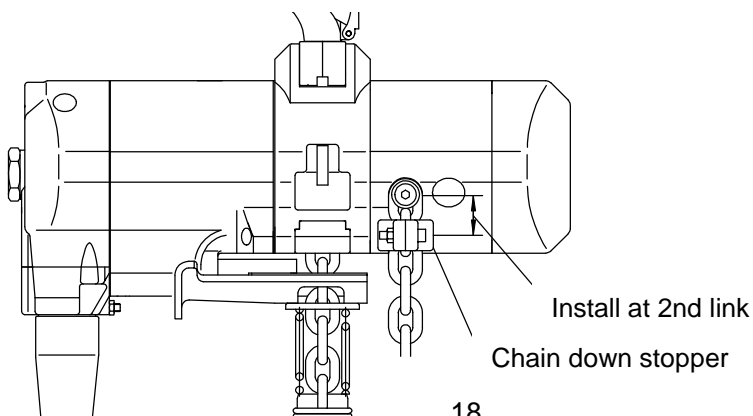

■ Checking the double chain type for twist

WARNING



Mandatory

In the double chain type, a hook block may have passed between chains, twisting them. Before using the air hoist, check the chains for any twist to use it with no twisted chains.

If used with twisted chains, they may be broken, resulting in a grave accident such as death due to a fall of the suspended load.

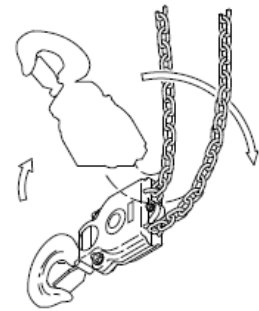

■ Attaching the Chain Container

■ Canvas chain container

A chain container has not been attached to the air hoist body. Attach it as illustrated in the following figure. After attaching the container, store the chain in the container without entwining it.

- (1) Fix the arm part of the chain bag to the air hoist body with a hanger bolt (M8), plain washers ($\varnothing 8$) and U-nut (M8).

When this is done, tighten the hanger bolt until a split pin hole in its end comes out of the U-nut.

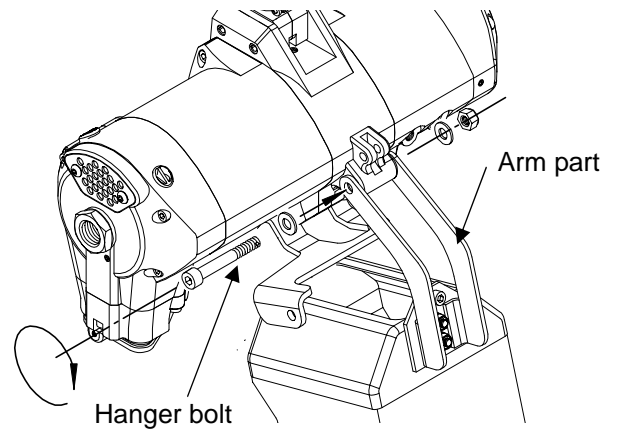

- (2) Fix the end of the chain to the air hoist body with a hanger bolt (M6), plain washers ($\varnothing 6$) and U-nut (M6).

When this is done, tighten the hanger bolt until a split pin hole in its end comes out of the U-nut.

Attach the chain in such a manner that it will not be twisted.

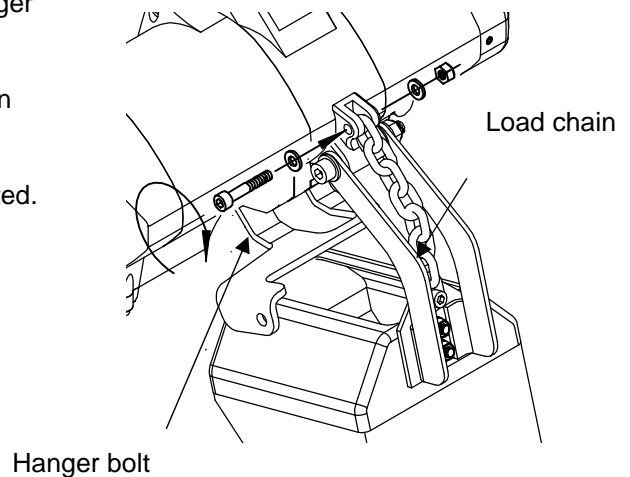

- (3) Attach split pins 2 x 15 and 2.5 x 20 to the hanger bolts M6 and M8, respectively, to secure them.

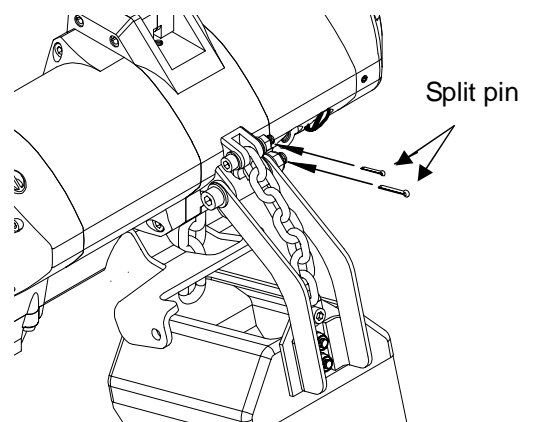

■ Attaching the Upper Accessory

The air hoist may be used in line with the customer's intended purpose by replacing the upper accessory. Prior to use, attach the accessory in the following procedures.

⚠ CAUTION



Mandatory

When replacing the upper accessory, make sure that a spring pin or hanger pin insertion hole in the wheel housing has not been worn or damaged, and that the concave part has not been deformed or cracked.

Failure to comply with this instruction may result in a serious accident such as a fall of the suspended load.

■ Hook suspended type (Top hook type)

When hooking the air hoist onto the structure to use it, attach a top hook.

The top hook has been attached to the air hoist beforehand upon delivery of the product. When changing from the trolley combined air hoist, however, follow the procedure below to attach the top hook.

■ 250 kg to 490 kg

- (1) Insert the top hook into the concave on the top of the air hoist.
- (2) Drive the spring pins ($\phi 8 \times 60$, 2 pcs.) from the side in such a manner that their grooves face downward.

Use new spring pins.

When attaching the top hook, use the pin punch (special tool, Tip diameter ϕ is 6 mm) to remove or drive the spring pin.

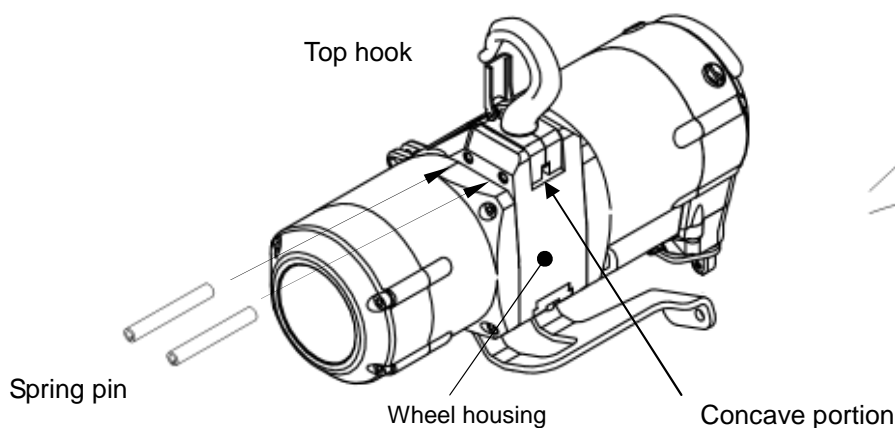
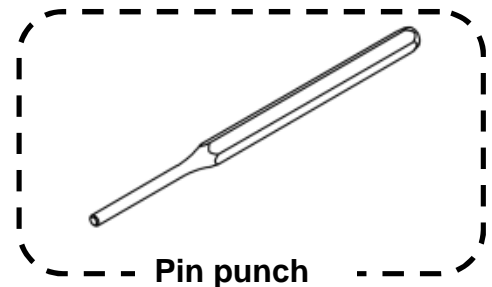

■ 980 kg

- (1) Insert the top hook into the concave on the top of the air hoist.
- (2) Drive the spring pins ($\varnothing 8 \times 60$, 2 pcs.) from the side in such a manner that their grooves face downward.
Use new spring pins.

When attaching the top hook, use the pin punch (special tool,
Tip diameter φ is 8 mm) to remove or drive the spring pin.

- (3) Fix the end of the load chain to the Part A of the connection yoke with a bolt, washer and U-nut.

When this is done, assemble the chain in such a manner that it will not be twisted.

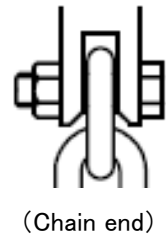
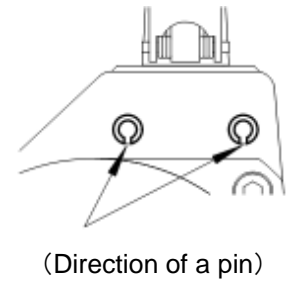
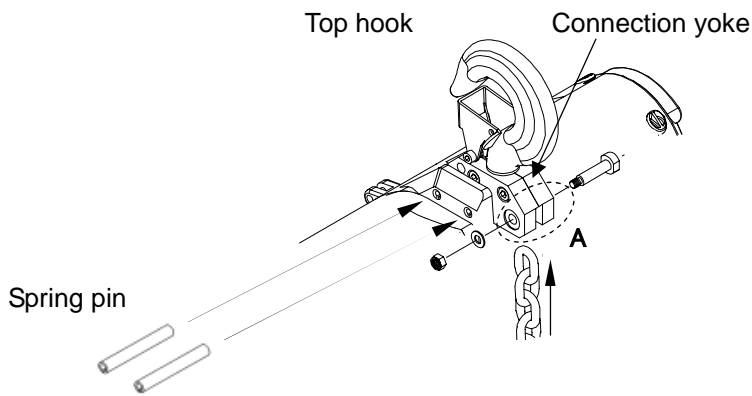
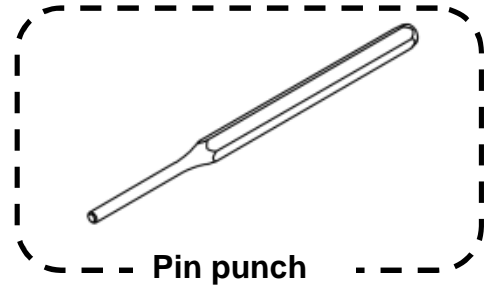

Manual trolley type

When combining the air hoist with a manual trolley, attach an exclusive suspender as illustrated in the following figure.

- (1) Set the top hook in the concave part on the top of the air hoist.
- (2) Drive the spring pins ($\varnothing 8 \times 60$, 2 pcs.) from the side in such a manner that their grooves face downward.

Use new spring pins.

When attaching the suspender, use the pin punch (special tool, Tip diameter φ is 6 mm) to remove or drive the spring pin.

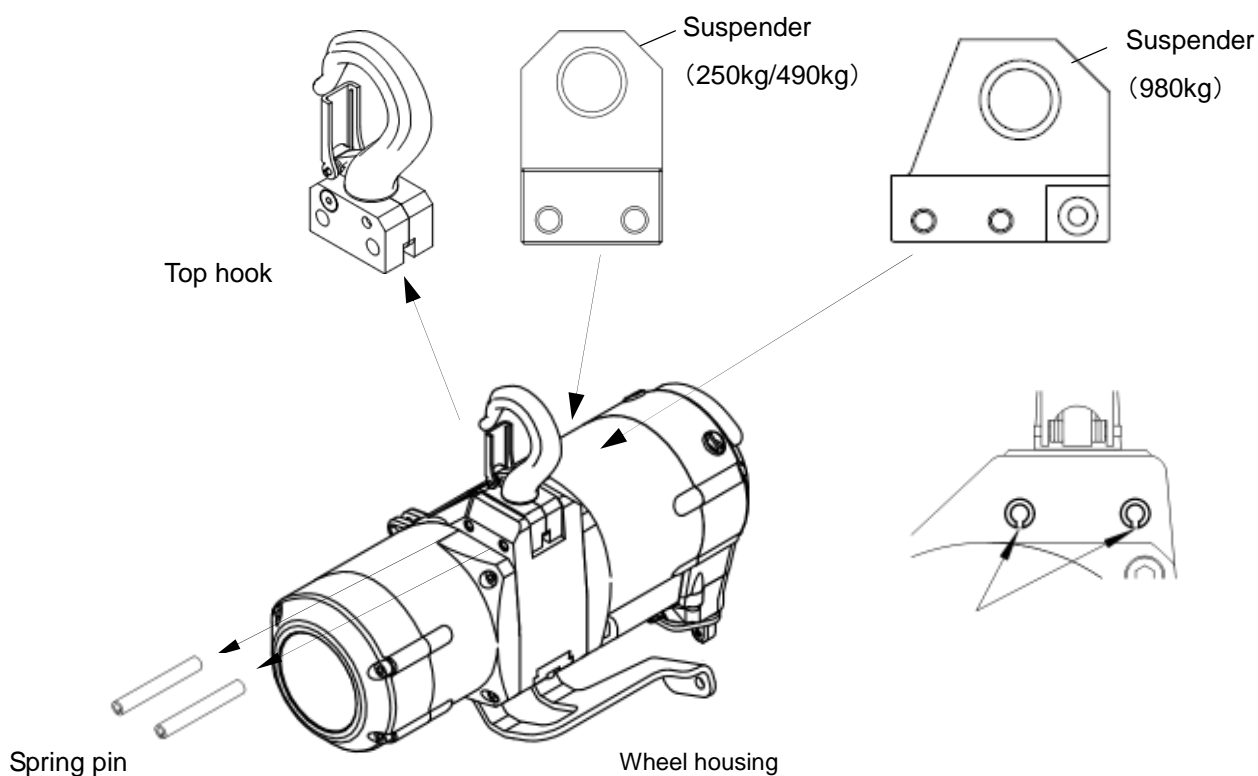
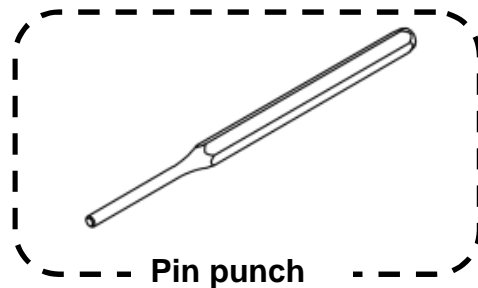

- (3) For the double chain type (980 kg), fix the end of the load chain to the Part A of the suspender with a bolt and U-nut. When this is done, assemble the chain in such a manner that it will not be twisted.

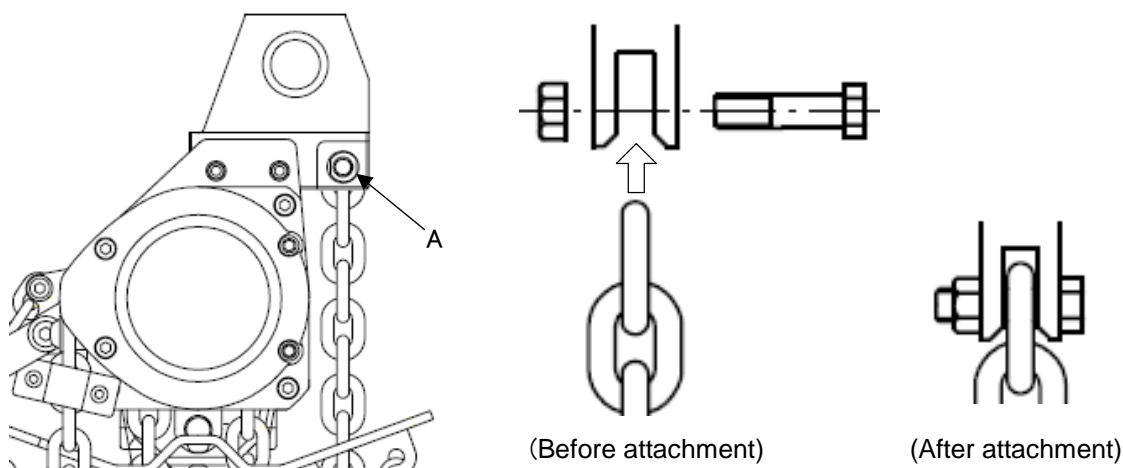

⚠ CAUTION



Prohibited

Do not hook the top hook of the air hoist directly onto the suspension shaft to use the air hoist. When using the air hoist with the trolley combined, use the exclusive suspender to combine. The TSC series air hoists are designed to be combined with a plain trolley (TSP). Do not use them in combination with a geared trolley (TSG).

Failure to comply with these instructions may not only fail to exert the successful functions and performance of the air hoist, but hinder safe operations, resulting in a grave accident.

■ Combine the Light Crane System

When using the air hoist as a Light crane system, see Page 28 as with the manual trolley to attach an exclusive suspender to the air hoist body and combine with the trolley in the following procedure.

- (1) Remove a clip from the trolley and pull out a pin from the trolley.

The pin is pulled out by pulling the Part A in the following figure to the near side and raising a lever.

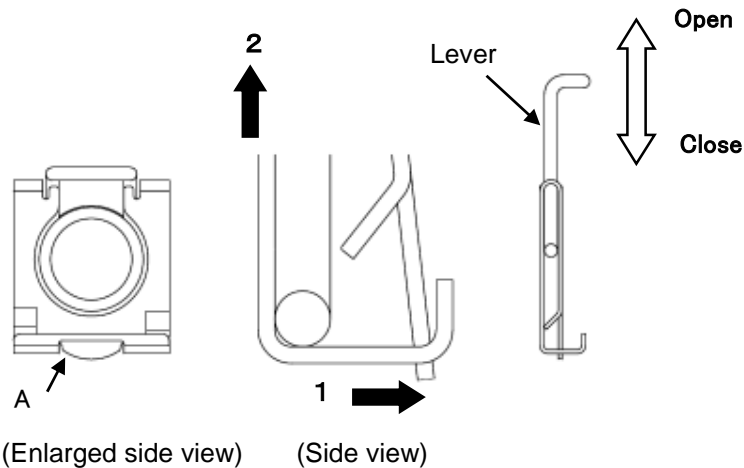

(Front view) (Enlarged side view) (Side view)

- (2) Insert the suspender of the air hoist from below, put through the pin and secure with the clip.

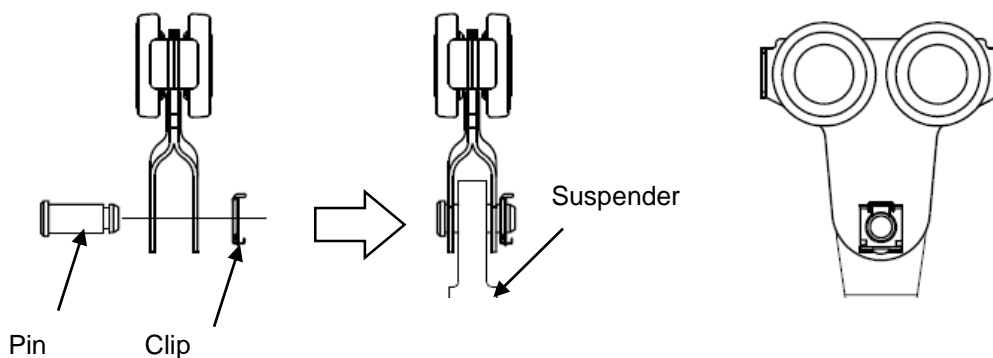

(Attaching to the single type trolley)

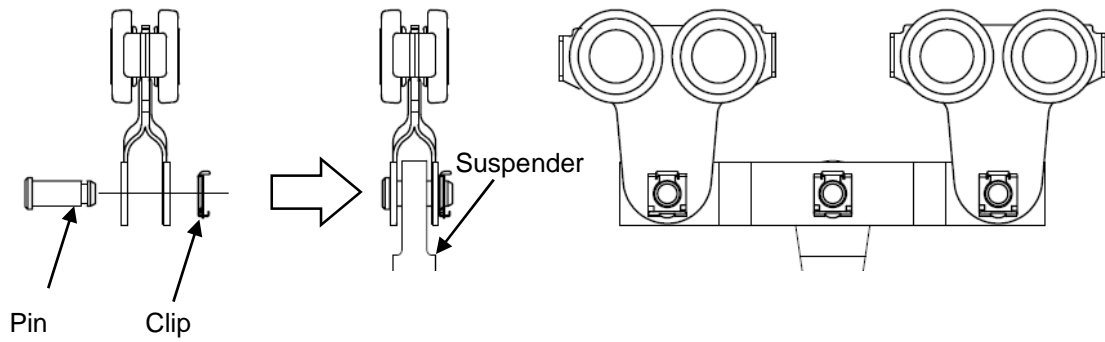

(Attaching to the double type trolley)

⚠ CAUTION



Mandatory

Be sure to close the lever and secure the pin with the clip of the Light crane trolley.

Failure to comply with this instruction may cause the pin to come off, resulting in a serious accident such as a fall of the suspended load.

■ Combining with the Trolley and Adjusting the Applicable Rail Width

■ Manual trolley type

The manual trolley is packed and delivered separately from the air hoist body.

When combining the air hoist with the manual trolley for use, it is necessary to combine the hoist body with the trolley and adjust the frame distance of the trolley according to the service rail width. Assemble in the following procedure.

- (1) Insert a suspension shaft from inside the frame G or S and insert a spacer from the end of the suspension shaft.

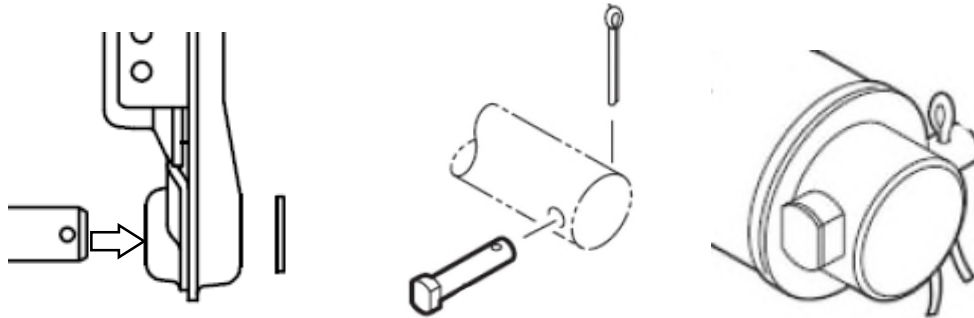

(Inserting the suspension shaft) (Inserting the shaft stopper pin) (Fixing with the split pin)

- (2) Insert the shaft stopper pin into a hole in the end of the suspension shaft and fix with the split pin.

Using the new split pin, open their end properly so that it will not come off. (End angle 70° or more)

- (3) Paying attention to the positional relationship between the nameplates of the air hoist body and trolley, check the trolley assembly direction.

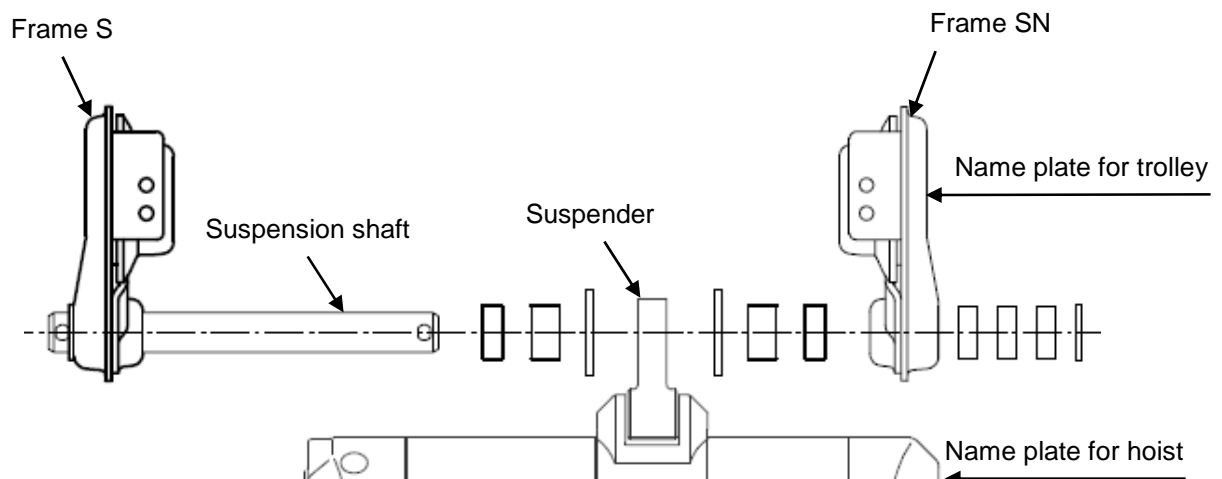

(4) According to the following table, check the number and arrangement of different collars suitable to the rail width and insert the required number of them onto the suspension shaft.

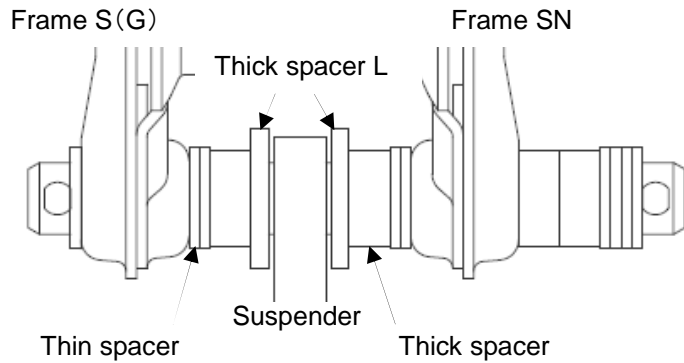

Capacity	Trolley	Rail width		Thin spacer	Thin spacer	Thick spacer	Thick spacer L	Thick spacer L	Thick spacer	Thin spacer	Thin spacer	Thick spacer	Thin spacer	(Unit:piece)		
		(inch)	(mm)											Thin spacer	Thin spacer	Thick spacer
250kg 490kg	TSP	2	50	1	Frame S(G)	3	0	1	Suspender	1	0	2	Frame SN	4	4	1
		2-5/16	58	1		4	0	1		1	0	3		2	4	1
		2-1/2,2-5/8	64,66	1		1	1	1		1	1	0		8	2	1
		2-7/8,2-15/16	73,74	1		2	1	1		1	1	1		6	2	1
		3	75,76	1		2	1	1		1	1	2		5	2	1
		3-1/4	82	1		3	1	1		1	1	3		3	2	1
		3-9/16	90,91	1		1	2	1		1	2	0		8	0	1
		3-7/8	98	1		2	2	1		1	2	1		6	0	1
		3-15/16	100	1		2	2	1		1	2	2		5	0	1
		4	102	1		3	2	1		1	2	2		4	0	1
980kg	TSP	2-5/16	58	1	3	0	1	1	0	3	2	6	1			
		2-1/2,2-5/8	64,66	1	0	1	1	1	1	1	0	8	4	1		
		2-7/8,2-15/16	73,74	1	1	1	1	1	1	1	6	4	1			
		3	75,76	1	2	1	1	1	1	1	5	4	1			
		3-1/4	82	1	3	1	1	1	1	2	3	4	1			
		3-9/16	90,91	1	0	2	1	1	2	0	8	2	1			
		3-7/8	98	1	1	2	1	1	2	1	6	2	1			
		3-15/16	100	1	2	2	1	1	2	1	5	2	1			
		4	102	1	2	2	1	1	2	2	4	2	1			
		4-3/16	106	1	3	2	1	1	2	2	3	2	1			
		4-5/16	110	1	3	2	1	1	2	3	2	2	1			
		4-7/16	113	1	4	2	1	1	2	3	1	2	1			
		4-11/16,4-3/4	119,120	1	1	3	1	1	3	0	7	0	1			
		4-15/16	125	1	2	3	1	1	3	1	5	0	1			
		5	127	1	2	3	1	1	3	2	4	0	1			

Note) Arrange the spacers outside (right side) for the I-beam and inside (between the frame SN and collar) for the H-beam.

(5) Close the trolley frame, insert the remaining collars onto the suspension shaft, insert the shaft stopper pin into the end of the suspension shaft, and fix with the split pin. (See Step (1).)

■ Installing the Product

WARNING



Mandatory

Installation of the air hoist includes high-place work. Wear a safety belt and a helmet.
Before starting installation, secure stable foothold.

Failure to comply with this instruction may result in an accident which affects physical health.

WARNING



Mandatory

Installation (uninstallation) should be implemented by a professional contractor or personnel having expertise.

Install (uninstall) the air hoist properly according to the manual.

Once installation is completed, proceed to "Checking after Installation" (Page XX).

Failure to comply with these instructions may not only fail to maintain the successful functions and performance of the air hoist, but result in a grave accident such as a fall of the suspended load.

WARNING



Mandatory

Attach stoppers to both ends of the travel rail for the trolley

Make sure that the structure is strong enough to install the air hoist or the trolley.

Install the air hoist to the structure where you can suspend a load equivalent to 125% of the rated load and operate without hindrance.

Failure to comply with these instructions may not only fail to maintain the successful functions and performance of the air hoist, but result in a grave accident such as a fall of the suspended load.

WARNING



Prohibited

Do not install the air hoist in an outdoor place always exposed to rain and water splash or in a high-humidity place.

Do not install the air hoist in the moving area of another trolley or other mobile device (facility).

Do not operate the air hoist while its outer shell structural portion (body) is interfering with other object or being fixed.

Do not combine the air hoist with your traversing equipment without using our trolley.

Failure to comply with these instructions may not only fail to exert the successful functions and performance of the air hoist, but hinder safe operations, resulting in a grave accident.

■ Installing the hook suspended type (Single unit of hoist)

- Installation method and checking the installation site

⚠ WARNING



Mandatory

When using the hook suspended type (single unit of hoist), hook the air hoist properly until the safety claw of the top hook is firmly closed.

Install the air hoist in such a manner that the top hook and air hoist body can move freely. (Do not operate the air hoist in manner of restraining the top hook and air hoist body.)

Do not install the air hoist upside down.

Failure to comply with these instructions may lead to a grave accident such as death or serious injury.

■ Installing the trolley type

⚠ CAUTION



Mandatory

During installation, support the air hoist and trolley firmly so that they will not fall or tilt.

Failure to comply with this instruction may cause the product to fall, resulting in damage on properties or an accident having an effect on the health.

- Overhead installation by inserting from the end of the traversing rail

- (1) Check whether the frame distance of the trolley conforms to the applicable rail.
- (2) Check that the rail is horizontal.
- (3) Install the trolley from the end of the rail, with the air hoist combined.

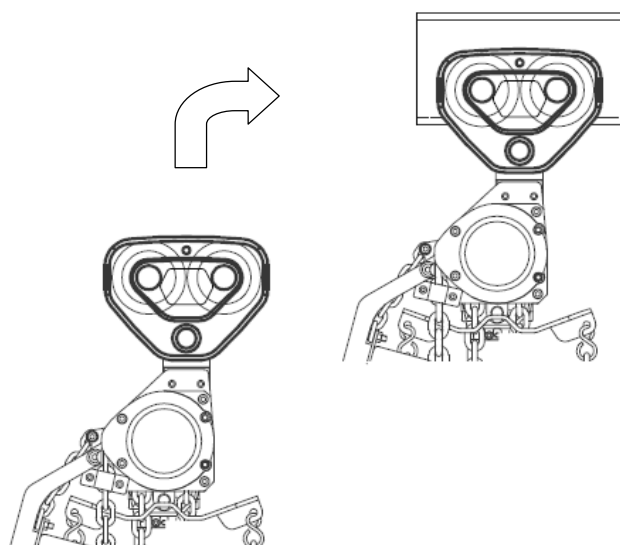

■ Overhead installation from below the rail by opening the trolley frame

(In the case of the manual trolley type)

(1) Open the trolley frame and insert from below the rail.

When this is done, support the air hoist to prevent the hoist body from falling and the trolley from tilting.

(2) Place one-side wheel on the rail flange and close the opposite frame.

(3) Put back the collars to their initial positions, insert a shaft stopper pin and fix with a split pin.

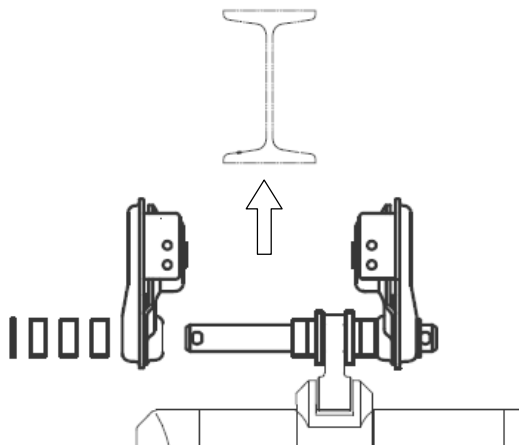

(Insert from below the rail)

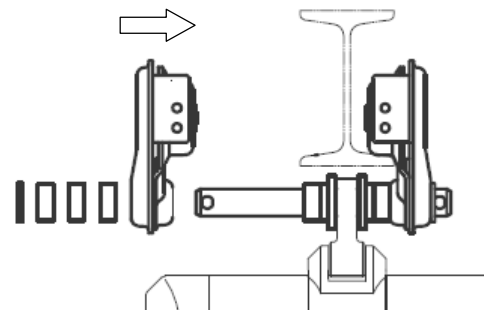

(One-side wheel is on the rail flange)



(Fix with a split pin)

■ **Attaching the traverse stopper**

■ In the case of the manual trolley type

When using the air hoist in combination with the manual trolley, see the instruction manual for the manual trolley.

■ **Routing the air supply hose**

The product does not come with an air supply hose and hanger. Consult us when you want to use them.

■ Checking after Installation

Wrong assembly or installation may result in a grave accident such as death due to a hoist trouble or a fall of the suspended load. In order to avoid such a danger, check the following after installing the product.

■ Check items

- Check whether or not bolts, nuts, snap pins and split pins are missing and properly tightened and assembled.
- Check whether or not a pendant wire has been reliably connected, and whether or not it receives a pendant pull force so as not to apply an excessive force to the air hose when the pendant is pulled.
- Check whether or not the air supply hose has been reliably secured and supported so that no excessive force is applied.
- Check whether or not the service air pressure has been adjusted to the specified value (recommended value: 0.6 MPa).

<When using the air hoist in combination with the trolley>

- Check whether or not the air hoist is combined with exclusive fittings and the hoist body faces in the proper direction.
- Check whether or not collars and spacers have been properly assembled, the trolley is free from tilt, and there are appropriate clearances among the traverse rail, trolley and wheel flanges of the manual trolley.
- Check whether or not deviation prevention stoppers have been reliably attached to the traverse rail for the trolley.
- Check whether or not the traverse rail for the trolley is horizontal, free from damage, deformation and adhesion of foreign substances and oil, and unpainted (bare metal surface).

■ Operation check

After installation, check the following items.

For the single unit air hoist



Check the items listed in "Air pressure and functions" on Page 44.

For the manual trolley

Check the items listed in "Functions of the manual trolley" on Page 46.

■ Adjusting the Maximum Speed

The TCS series is provided with a maximum speed adjusting mechanism. When the maximum lifting or lowering speed seems too high, the maximum speed can be lowered steplessly according to your need. The lifting and lowering speed adjusting mechanisms are independent of each other, allowing separate adjustments, respectively.

 CAUTION	
 Prohibited	Do not set the speed beyond the setting range. During low-speed operation, the air hoist may be operated while activating the brake, resulting in trouble due to the overheated brake.

- Adjusting method

As illustrated in the following figure, the lifting adjusting mechanism is located on the right side and the lowering one is on the left side when viewed from the valve side.

Using pliers, etc., pull out the red resin cover of the desired adjusting mechanism.

There is a slot inside. Using a regular screwdriver, etc., turn the slot to adjust. As illustrated in the following figure, the vertical position to the hoist body represents the highest value and the horizontal position represents the lowest value; adjust within this range.

This adjustment should be made when this product is stopping. While operating, the adjusting mechanism cannot be easily turned because the resistance increases due to higher inner pressure.

When turning the adjusting mechanism, it may feel heavy due to sliding resistance of an internal O-ring, but this is not a trouble.

It has been set to the highest-speed position upon shipment from the factory.

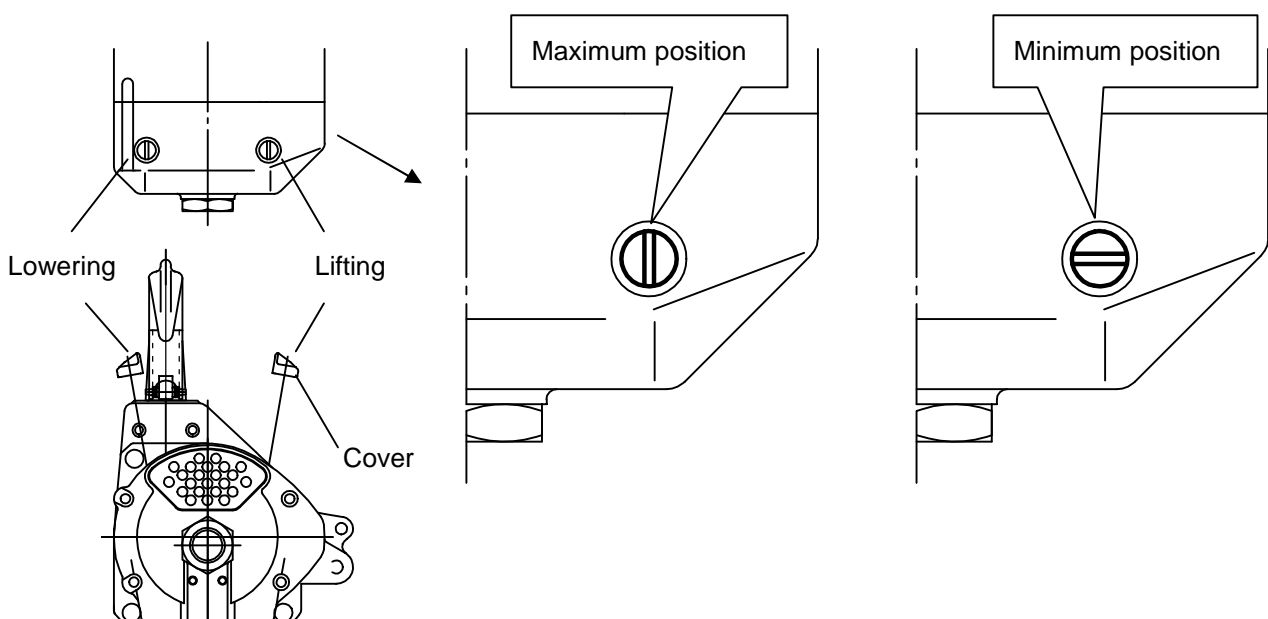

Operation

WARNING



Mandatory

To use the air hoist, observe its product specifications and operational environment.
Do not use the air hoist to lift, support or move a person.

If the air hoist is used beyond the limits of its product specifications and operational environment, it may not only fail to exert its successful functions and performance, but result in a grave accident.

WARNING



Prohibited

Do not use the load chain which has been considerably elongated, abraded or deformed beyond the service limit.

Do not cut off, add or weld the load chain.

Do not use in an environment where the load chain is exposed to sparks caused by welding, etc.

Do not bring a welding rod or welding electrode into contact with the load chain.

Do not use the load chain as grounding for welding.

Failure to comply with these instructions may break the chain and result in a grave accident such as death due to a fall of the suspended load.

WARNING



Prohibited

Do not use the hook which is disengaged from a safety claw or damaged.

Do not use the hook which does not turn smoothly.

Do not use the air hoist, if the air hoist is not reliably braked with no load applied or requires a long stopping distance.

Do not intentionally disable the overwinding prevention device to use the air hoist.

Failure to comply with these instructions may not only fail to exert the successful functions and performance of the air hoist, but hinder safe operations, resulting in a grave accident.

WARNING



Prohibited

While operating the air hoist, if the chain-down stopper is activated to prevent overwinding, the peripheral parts including the load chain may have been damaged. Be sure to contact our dealer or our office and ask for inspection and repair.

Failure to comply with these instructions may not only fail to exert the successful functions and performance of the air hoist, but hinder safe operations, resulting in a grave accident.

WARNING



Prohibited

The air hoist becomes hot during or after operation. To touch it, wait for a while after stopping and make sure that the surface temperature has dropped.

Touching the air hoist carelessly may cause burn.

CAUTION



Mandatory

Conduct daily inspection before using the air hoist.

The maintenance engineer should regularly examine the daily inspection results to check for any abnormality.

When informed of any abnormality or trouble of the air hoist, the maintenance engineer should immediately prohibit its operation, secure safety and ask for its inspection and repair.

Failure to comply with these instructions may not only fail to maintain the successful functions and performance of the air hoist, but result in a grave accident such as a fall of the suspended load.

CAUTION



Mandatory

Check work details and use the air hoist with sufficient rated load and lift.

Check work details and use the air hoist in a place free from any obstacles, allowing you to look over an operating range.

Operate the air hoist in a place with stable foothold free from danger of falling, tripping, sliding and tumbling.

When starting operation, inform the persons around you to that effect.

When you cannot look over the operating range, locate someone nearby to ensure safe operation.

Do not stay or operate the air hoist right below the suspended load.

Do not leave an operating position with a load suspended or look away from the suspended load.

When the product is permanently installed and repeatedly used for the same kind of work as well, check work details and ensure that the rated load is not exceeded.

Ensure that the nameplate and warning labels affixed to the hoist body are always clearly legible to the workers.

The air hoist is operated to move heavy objects. Operation without checking safety may result in a grave accident which affects physical health of workers such as death or serious injury.

CAUTION



Mandatory

Put on clothes which do not obstruct operation.

In order to protect a human body, put on a helmet, mask, safety shoes and gloves according to work details.

When operating or working near the air hoist, put on a protective gear such as ear plugs.

Failure to comply with these instructions may result in an accident which affects physical health.

NOTE

In order to ensure smooth inspection, test and management of the air hoist, choose the maintenance engineers or persons responsible for hoist handling from among those qualified for hoist operation, and put up their names in an easily visible place to bring it home to the workers.

Expertise and know-how are required for disassembling, reassembling and testing the air hoist.

When conducting maintenance work such as periodic inspection and replacement of parts, contact our office or our dealer.

■ Operating the Cord and Pendant

Depending on the air hoist model, there are two types of operating the air hoist, cord type and pendant type. Check your model and the type of operating method to operate the air hoist in a correct manner.

⚠ CAUTION



Prohibited

- Do not hang a cord or pendant hose on other object or pull them strongly.
- Do not tie or bundle the cord or pendant hose in order to adjust the length,
- Do not operate the cord or pendant hose if they are entangled.
- Do not operate the cord or pendant hose carelessly if they are improperly attached.
- Do not use the cord or pendant if the air hoist moves in the direction different from cord or pendant operation or does not move.
- Do not attach a weight to the cord or tape around a pendant lever to use in the fixed state.
- Do not pull two cords at the same time or push multiple pendant levers at the same time.
- Do not use the cord or pendant if the air hoist does not move smoothly in response to cord or pendant operation.
- Do not use the cord or pendant in an environment where they are splashed with a chemical, solvent and oil.
- Do not use the emergency stop button to stop the air hoist in regular operation.

If the air hoist is used in a wrong manner or with abnormality existing, it may not only fail to exert its successful functions and performance, but hinder safe work, resulting in a grave accident,

NOTE

When releasing the cord or pendant after operation, do not throw them at the structure or other workers.

■ Cord type

The cord type is provided with two cords in the operating portion. Lifting or lowering operation is performed by pulling one of these cords. The air hoist is halted by releasing the handle (grip).

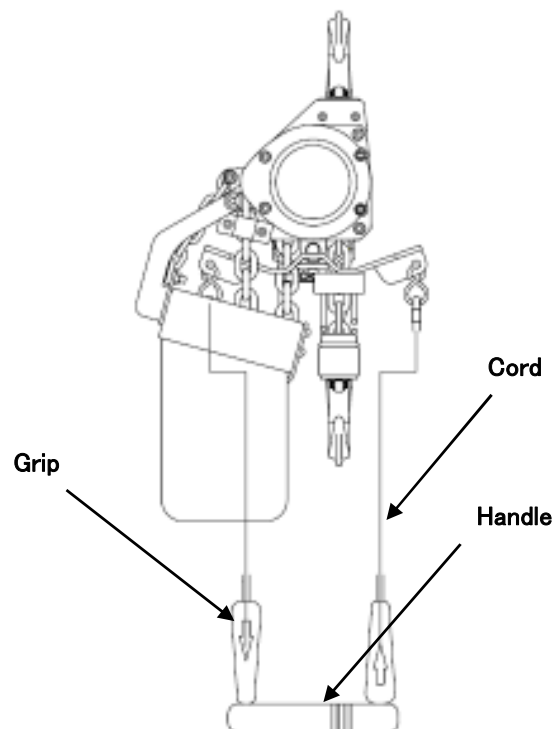

The speed is adjusted by how much you pull the cord.

As illustrated below, the speed is decreased by pulling the cord less and increased by pulling more, allowing stepless speed adjustment.

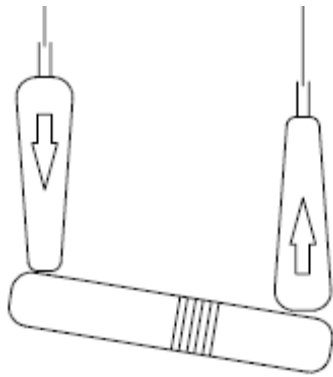

(Lift: Slow)

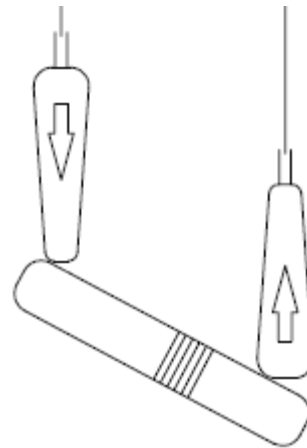

(Lift: Fast)

■ Pendant type

The pendant type allows lifting, lowering or traversing operation by pressing down the levers in the operating portion.

The air hoist is activated by pressing down any lever of the pendant and braked to stop by releasing it.

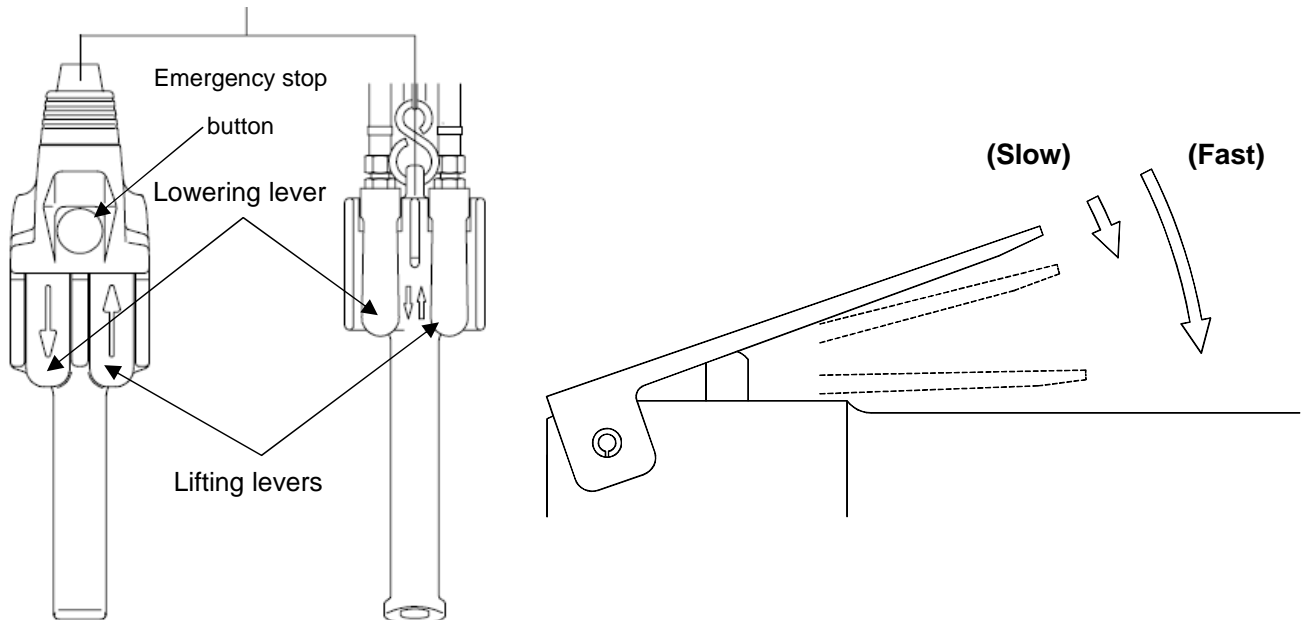

The speed is adjusted by changing the extent of pressing down the lever.

The speed is decreased by pressing down the lever less and increased by pressing down more, allowing stepless speed adjustment.

■ Precautions for Operation

■ At the time of slinging

WARNING



Prohibited

- Do not hang the suspended load on the hook end or the safety claw.
- Do not lift the suspended load with the safety claw left open.
- Do not bind the suspended load with load chain directly.
- Do not operate the load chain while it is in contact with any sharp edges.
- Do not apply a load to or lift the suspended load with the load chain on the no-load side.

Failure to comply with these instructions may result in a grave accident due to a hoist trouble or a fall of the suspended load.

CAUTION



Mandatory

- Use slinging tools suitable to the weight and shape of the suspended load.
- Sling the suspended load so as to equally apply a load to the slinging tools, and lift it in a stable manner.
- Attach the slinging tools reliably so that the suspended load will not fall or tilt.
- Do not dare to lift the structure or any other object supposed to be difficult to lift.
- Do not use the slinging tools to reverse the suspended load. Use a special-purpose reversing device.

Improper slinging not only hinders efficient work, but results in a grave accident due to a fall of the suspended load.

■ At the time of lifting/lowering

WARNING



Prohibited

- Do not lift more than the capacity.
- Do not operate the air hoist exceeding the lifting height.
- Do not stop the air hoist with the overwinding prevention device.

Failure to comply with these instructions may not only cause a hoist trouble, but result in a grave accident due to a fall of the suspended load.

Do not use the air hoist in such a manner that when the suspended load is lifted, the air hoist will serve as a supporting point and apply an external force to the outer shell structural portion (body) of the hoist.

Do not swing the suspended load.

Do not lift the suspended load at a stretch with the load chain or sling slackened.

Do not operate the air hoist with the load chain entangled.

Do not perform abrupt reserving operation (plucking) halfway lifting or lowering operation.

Do not perform excessive inching (micromovement).

Wrong operation of the air hoist may not only cause a hoist trouble, but result in a grave accident.

 **WARNING**



Prohibited

Do not put your hand close to the chain inlets (chain separator and chain lever) at the lower part of the air hoist at the time of overlifting or overlowering.

Failure to comply with this instruction may have your finger rolled into the chain inlet or have your hand caught between the chain lever and the hoist body, resulting in bodily injury.

 **CAUTION**



Mandatory

When the overwinding prevention device is activated to stop the air hoist, lower the suspended load immediately, check its position and operate within the non-operating range of the overwinding prevention device.

Failure to comply with these instructions may not only cause a hoist trouble and hinder safe operation, but result in a grave accident.

Lift the suspended load directly overhead with respect to the air hoist. (Do not lift a load in an inclined direction.)

When lifting from a cargo deck, etc., do not operate the air hoist as if dropping the suspended load in the slung state.

Do not disassemble, reassemble, weld or cut off the suspended load in the lifted state.

Wrong use may not only cause a hoist trouble and hinder safe operation, but result in a grave accident.

 **CAUTION**



Mandatory

When a lifting magnet or a vacuum suction machine is used to transport the suspended load, transport it as low as possible.

Failure to comply with this instruction may result in a grave accident due to an unexpected fall of the suspended load.



Prohibited

Do not use two or more air hoists to simultaneously lift one suspended load.

Failure to comply with this instruction may result in a grave accident due to an unexpected load shift or fall of the suspended load.

The air hoist adjusts its speed with the operating cord or the pendant. It is not suitable for simultaneously lifting the suspended load at constant speed, using multiple units of them.



Mandatory

In the loaded state, the lowering speed may be 1.5 to 2 times faster than the lifting speed.

During lowering operation, pay attention to the movement and position of the suspended load, and implement low-speed operation to avoid a collision.

Failure to comply with these instructions may cause an unexpected collision, load shift and fall of the suspended load, leading to a serious accident.

■ At the time of traversing/traveling

WARNING



Prohibited

Do not operate the air hoist while standing between the suspended load and the building wall.

The suspended load may sway and catch the operator against the building wall, resulting in a grave accident such as death or serious injury.

With the load suspended, do not operate or move the air hoist while moving backward.

The suspended load may sway, be pushed and fall, resulting in bodily injury.

CAUTION



Prohibited

Do not put your hand close to a trolley wheel during operation.

The hand may be caught by the trolley wheel, resulting in bodily injury.

Do not allow the suspended load to catch other structure or wiring.

Do not operate the air hoist with the hand chain of the manual trolley left entangled.

Failure to comply with these instructions may not only fail to exert the successful functions and performance of the air hoist, but hinder safe operations, resulting in a grave accident.

■ At the occurrence of abnormality/trouble

WARNING



Mandatory

When the air hoist is damaged or emits abnormal sound or vibrations, stop its use immediately, put up a notice "Out of Order" and contact the maintenance engineer.

When the power to the air hoist is shut off due to a blackout, leave the air hoist immediately, secure ambient safety and contact the maintenance engineer.

If the air hoist is used in a wrong manner or with abnormality existing, it may not only fail to exert its successful functions and performance, but hinder safe operation, resulting in a grave accident.

■ After daily work

CAUTION



Prohibited

Do not finish operating the air hoist or store the air hoist in the overlifting or overlowering state.

Do not suspend operation of the air hoist for a long time or store the air hoist with the power left supplied to it.

If the air hoist requires repair, put up a notice "Out of Order" so that it will not be used by mistake.

To store the air hoist, wipe off dirt and water drops and lubricate the hook neck and the load chain.

To store the components such as the overlifting prevention device, overlowering prevention device and chain container where the load chain passes or is housed, remove dirt, foreign substances and water drops from them in a similar manner.

Failure to comply with these instructions may not only fail to exert the successful functions and performance of the air hoist, but result in a grave accident.

NOTE

Always clean the cord and the pendant to eliminate dust, sand, oil, rubbish, and so on.

When storing the air hoist for a long period of time, periodic no-load operation is effective to prevent rusting of each part.

When lowering the air hoist down onto the floor, remove the container or prepare sleepers in order to protect it from deformation and damage.

When the air hoist is not used, lift the hook to the position which does not disturb passage of workers and other work.

Decide a storage place beforehand. It is recommended to hang the cord and the pendant on a post, etc.

Maintenance

■ Daily inspection

Daily inspection is mainly conducted by the operator of the air hoist for checking its condition through visual check and no-load operation.

⚠ WARNING



Mandatory

Before using the air hoist, conduct daily inspection.
If an abnormality is found during inspection, turn off the air hoist, put up a notice "Out of Order" and contact the maintenance engineer.

Failure to comply with these instructions may not only fail to maintain the successful functions and performance of the air hoist, but result in a grave accident.

⚠ CAUTION



Mandatory

Disassembly/reassembly of the air hoist requires expertise and know-how. When maintenance is required such as replacement of parts as a result of daily inspection and regular inspection, contact our dealer or our office.

Failure to comply with these instructions may not only fail to maintain the successful functions and performance of the air hoist, but result in a grave accident.

■ Hoist body

■ Appearance

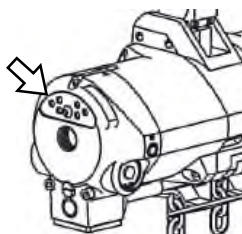

Item	Check method	Criteria	When failed
Nameplates, labels and tags	Check visually.	No peel off. Indication can be seen clearly.	Carry out cleaning or replace with new nameplate, label and tag.
Body and each part	Check visually.	No apparent deformation, damage, flaw and crack	Replace the parts.
Exhaust section and periphery	Check visually.	Should be free from considerable adhesion of oil and clean.	Clean the exhaust section and periphery.
Bolts, nuts, and split pins	Check visually.	Should be reliably attached without being loosened or missing.	Fasten bolts, nuts and split pins a securely.

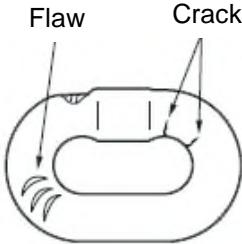

■ Load chain

Item	Check method	Criteria	When failed
Pitch	Check visually.	No apparent elongation	Measure the dimension and replace the part if it exceeds the criterion.
Chain diameter	Check visually.	No apparent abrasion	Measure the dimension and replace the part if it exceeds the criterion.
Deformation, flaw and entanglement	Check visually.	<ul style="list-style-type: none"> - No deep notch - No deformation such as twist - No attached sputter - No entanglement - No crack <div style="text-align: center; margin-top: 10px;">  </div>	Replace the load chain.
Rust and corrosion	Check visually.	No apparent rust and corrosion	Apply the specified lubricant. Apply the specified lubricant.
Twist	Check visually.	No capsized link at bottom hook of double type load chain	Untwist the load chain.
Lubrication	Check visually.	To be oiled adequately	Apply the specified lubricant.
Mark pitch and indication	Check visually.	<ul style="list-style-type: none"> - Should be marked at a correct position. - Correct indication should be marked. 	Replace the load chain.

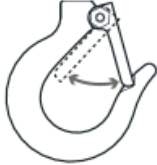
■ Hook

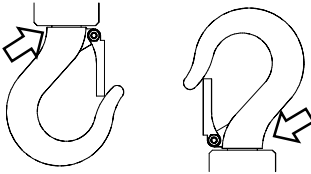
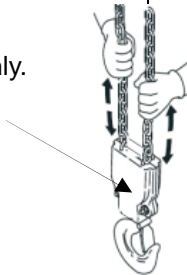
Item	Check method	Criteria	When failed
Opening of the hook	Check visually.	No apparent opening of the hook.	Measure the dimension and replace the part if it exceeds the criterion.
Abrasion	Check visually.	No apparent abrasion	Measure the dimension and replace the part if it exceeds the criterion.
Deformation, flaw and corrosion	Check visually.	No apparent deformation, flaw and corrosion	Replace the hook.
Hook latch	Check visually and check the movement of the Hook latch.	- The safety claw is mounted securely inside the hook opening. - No deformation. The Hook latch moves smoothly. 	Replace the Hook latch, bolt and nut.
Movement of bottom hook (Rotation)	Check visually and rotate the hook by hand.	Should rotate lightly by 360° to the right and left. 	Replace the damaged part such as the bottom hook.
Hook neck	Check visually.	 <p>The hook neck should be free from a considerable clearance (backlash).</p>	Replace the damaged part such as the bottom hook.
Free chain wheel (In the bottom yoke)	Operation Move the load chain up and down to check movement of the free chain wheel.	- The free chain wheel rotates smoothly. (If the bearing is broken or the support shaft is deformed, the free chain wheel does not rotate smoothly.) - The chain moves smoothly. <p>Bottom yoke</p> 	Replace the damaged parts such as the free chain wheel and the bearing.

■ Peripheral parts of the body

Item	Check method	Criteria	When failed
Spring	Check visually.	No apparent shrinkage, twist and deformation 	Replace the spring.
Chain washer Chain down stopper	Check visually.	No apparent deformation, damage, flaw and crack	Replace the damaged parts.
Chain lever	Check visually.	No apparent deformation, damage, flaw and crack	Replace the damaged part.
Air supply hose joint	Check visually.	Should be free from air leak and firmly fixed.	Fix firmly with a hose band.

■ Cord or pendant

Item	Check method	Criteria	When failed
Operating portion	Check visually. No-load operation	<ul style="list-style-type: none"> - No deformation, damage and no loosened screw - The cord and pendant hose joints should be free from twist, looseness and missing. - The cord and the lever should be operated smoothly. - The emergency stop button should be turned on and off. 	<p>Replace the damaged parts.</p> <p>Remove or correct the cause of operational failure.</p>

■ Air pressure and functions

Check the following item with no load.

Item	Check method	Criteria	When failed
Air pressure	Check visually.	The operating air pressure should be 0.4 to 0.6 MPa (recommended pressure: 0.6 MPa).	Adjust to the appropriate pressure.
Lubrication	Check visually.	Lubrication should be implemented by the lubricator (line oiler) at a rate of 10 to 15 drips (2 to 3 cc) per minute.	With the lubricator, adjust a lubrication rate appropriately.

Item	Check method	Criteria	When failed
Operational check	Operate the cord or the pendant.	<ul style="list-style-type: none"> - The load chain can be wound smoothly. - The air hoist should move in the same direction as cord or pendant (lever) operation. - When the operation is stopped, the motor stops immediately. - When the emergency stop button is pressed, all hoist motions stop. - When operating other push button while the emergency stop button is pressed, the hoist does not start operation. - When canceling the emergency stop button, the hoist operates normally. 	Ask for inspection and repair.
Brake	Operate the cord or the pendant.	- When stopping the operation, the brake is applied immediately and bottom hook shall stop immediately.	Ask for inspection and repair.
Overwinding prevention device	Operate the cord or the pendant to run the air hoist at low speed.	Configuration of parts and routing of the chain should be appropriate for activating the device. The limit lock, bottom hook or chain should push back the chain lever at the lifting limit or the lowering limit to deactivate the device reliably.	Correct configuration of parts and routing of the chain appropriately. If the device is not deactivated reliably, ask for inspection and repair.
Abnormal sound and vibrations	Operate the cord or the pendant to check an operating sound.	No abnormal sound and vibrations	Ask for inspection and repair.

■ Manual trolley

■ Appearance

Item	Check method	Criteria	When failed
Nameplates, labels and tags	Check visually.	No peel off. Indication can be seen clearly.	Carry out cleaning or replace with new nameplate, label and tag.
Body and each part	Check visually.	No apparent deformation, damage, flaw and crack	Replace the parts.
Bolts, nuts and split pins	Check visually. tool	Should be reliably attached without being loosened or missing.	Fasten bolts, nuts, split pins and snap pins securely.

■ Functions of the manual trolley

Check the following item with no load.

Item	Check method	Criteria	When failed
Operational check	Operate the hand chain to perform traversing.	Should traverse smoothly without meandering and vibrations.	Ask for inspection and repair.

■ Frequent inspection

Frequent inspection should be conducted by the maintenance engineer or the person designated by the maintenance engineer, mainly through visual check and measurement. Conduct frequent inspection after checking daily inspection items. When the air hoist has not been used over one month, conduct frequent inspection before using it again.

■ Hoist body

■ Load chain

- Check the load chain after removing the stain on the chain.
- Use the needle head caliper (point caliper) to measure the sum of pitches and chain diameter.
- Apply oil on the load chain after inspection.

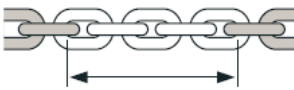
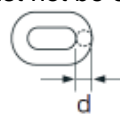

Item	Check method	Criteria	When failed
Pitch	Measure the pitch with point caliper.	The limit value of the following "Sum of pitches of five links" must not be exceeded.  Sum of pitches of five links	Replace the load chain.
Chain diameter	Measure the chain diameter (d) with point caliper.	The limit value of the following "Chain diameter of the load chain" must not be exceeded. 	Replace the load chain.

Capacity	Code	Sum of pitches of 5 links (mm)		Load chain diameter d (mm)	
	Hook suspended Manual trolley type	Do not exceed the limit		Do not fall under the limit	
		Standard	Limit	Standard	Limit
250kg	TCSH03CS/PS	95.5	98.3	6.3	5.7
490kg	TCSH04CS/PS				
980kg	TCSH09CD/PD				

<After inspecting the load chain>

- The use of lubricant has a great effect on wear (service life) of the load chain. Use KITO's original lubricant or equivalent (industrial general-purpose lithium grease, consistency number 0).
- With no load applied to the load chain, lubricate the load sheave, link engaged with the free chain wheel, and linking part of the chain.
- After lubricating, perform lifting and lowering with no load applied to adapt the lubricant to the chain.

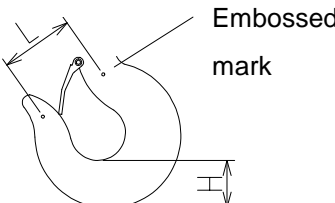
■ Hook

Item	Check method	Criteria	When failed
Opening and abrasion of the hook	Check visually and measure with vernier caliper.	Should not exceed the following service limit value. The opening dimension L should be less than “L + 2” mm, compared with the dimension of new item. The height H of the hanging part should exceed “H – 2” mm. 	Replace the hook.
Deformation, flaw and corrosion 	Check visually.	<ul style="list-style-type: none"> - No deformation such as bend or twist - No deep cut - No loosened bolt or nut for safety claw, or their fall off - No considerable corrosion - No attachment of foreign matter such as sputter 	Replace the hook.

■ Peripheral parts of the body

Use check stand to check the air hoist from the close point.

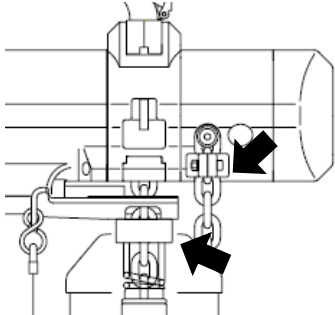
Item	Check method	Criteria	When failed
Chain container	Check visually.	<ul style="list-style-type: none"> - To be mounted to the body securely - No damage, tear, abrasion or deformation - Check no foreign matter inside the chain container. - The lift of the air hoist should be shorter than the allowable storage length indicated on the chain container. 	Replace the chain container. Remove the foreign matter in the chain container.
Chain end on the no-load side	Check visually.	<ul style="list-style-type: none"> - The bolts (screws) used for securing the chain to the hoist body should be tight and not missing. - The chain-down stopper locking bolts should be tight and not missing. 	Tighten with appropriate torque. $T = 12N \cdot m$
Chain fixing part peripheral parts on the no-load side Chain-down stopper Chain washer	Check visually.	No apparent deformation, damage and crack 	Replace the damaged parts.

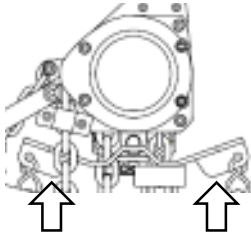
Item	Check method	Criteria	When failed
Chain lever	Check visually.	No apparent deformation, damage and crack 	Replace the damaged part.

■ Cord or pendant

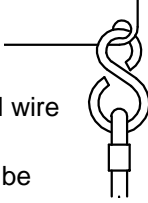
Item	Check method	Criteria	When failed
Operating portion/supporting portion	Check visually. No-load operation	<p>Cord type:</p> <ul style="list-style-type: none"> - The S-shaped wire should not be opened. - The hanging part of the S-shaped wire should not be deformed. - The cord caulked part should not be disengaged. - The cord (string) should not be damaged. <p>Pendant type:</p> <ul style="list-style-type: none"> - The pendant hose joint should be tight. - The pendant hose should not be damaged. - The pendant hose supporting wire or the chain fixing screw should be reliably attached without looseness so that no force will be applied to the hose even if the pendant is pulled. 	<p>Replace the damaged parts.</p> <p>Attach the pendant hose and the supporting wire reliably.</p>

■ Air supply hose and joint

Item	Check method	Criteria	When failed
Appearance Attachment	Check visually.	<ul style="list-style-type: none"> - The air supply hose should not be deformed or damaged. - The hose band, etc. should be tight at the joint to the air hoist or the trolley. 	<p>Replace the damaged parts.</p> <p>Attach the air supply hose reliably.</p>

■ Functions

Check the following item with no load.

Item	Check method	Criteria	When failed
Abnormal sound	No-load operation Check in the vicinity of the hoist body.	- To sound no irregular noise - To sound no howling of motor and scraping sound of the brake - There should be no chain crackling sound emitted from near the chain separator (chain inlet/outlet).	Ask for inspection and repair.

■ Periodic inspection

Periodic inspection requires expertise and know-how. Ask our office or our dealer for periodic inspection because it includes overhaul of the product, operation check under the rated load, and so on, requiring replacement of parts from time to time.

When asking for periodic inspection, fill in Periodic Inspection Request Sheet on the next page and contact our office or dealer.

<Air Hoist Periodic Inspection Request Sheet>

Date	
------	--

1. Customer Information

(1) Company name	
(2) Address	
(3) Phone	
(4) Contact person	

2. Product Information

(1) Product type (Code)	
(2) Serial No.	
(3) Date of purchase	
(4) Product use period	to
(5) Daily working hours	hours
(6) Annual working days	days
(7) Weight of suspended load or limits of weight	kg to kg
(8) Frequency of use (push button operation count for each work)	High Low
(9) Working atmosphere	Regular Special (gas, powder dust, oil mist, and others ())
(10) Working temperature	High Regular Low

Note) For Items (1) and (2), enter the code and number inscribed on the hoist's nameplate.

3. Questions and Inconveniences in Using the Product

--	--

■ Check Sheet for Daily Inspection

Model	Code	Capacity	Serial No.	Your CTRL No.	Installation date	Location
Air hoist						

Category	Check item	Check method	Criteria	Inspection date/result					
				/	/	/	/	/	
Appearance	Nameplates, labels and tags	Check visually.	No peel off. Indication can be seen clearly.						
	Body and each part		No apparent deformation, damage, flaw and crack						
	Exhaust section and periphery		Should be free from considerable adhesion of oil and clean.						
	Bolts, nuts, split pins and snap pins		Should be reliably attached without being loosened or missing.						
Load chain	Pitch		No apparent elongation						
	Chain diameter		No apparent abrasion						
	Deformation, flaw and entanglement		No deep notch, No deformation such as twist No attached sputter, No entanglement, No crack						
	Rust and corrosion		No apparent rust and corrosion						
	Twist		o capsized link at bottom hook of double type load chain						
	Lubrication		To be oiled adequately						
	Mark pitch and indication		Should be marked at a correct position. correct indication Should be marked.						
Hook	Opening of the hook		Check visually and check the movement of the hook latch.	No apparent opening of the hook.					
	Abrasion			No apparent abrasion					
	Deformation, flaw and corrosion	No apparent deformation, flaw and corrosion							
	Hook latch	Check visually and lotate the hook by hand.	The hook latch is mounted securely inside the hook opening. No deformation. The hook latch moves smoothly.						
	Movement of bottom hook (Rotation)	Check visually.	Should rotate lightly by 360° to the right and left.						
	Hook neck	Operation Move the load chain	Should rotate lightly by 360° to the right and left.						
Peripheral parts of the body	Free chain wheel (In the bottom yoke)	Check visually.	The free chain wheel rotates smoothly. The chain moves smoothly.						
	Spring		No apparent shrinkage, twist and deformation.						
	Chain washer Chain down stopper		No apparent deformation, damage, flaw and crack						
	Chain lever		No apparent deformation, damage, flaw and crack						
Cord or pendant	Air supply hose joint	Check visually. No-load operation	Should be free from air leak and firmly fixed.						
	Operating portion		No deformation, damage and no loosened screw The cord and pendant hose joints should be free from twist, looseness and missing. The cord and the lever should be operated smoothly. The emergency stop button should be turned on and off.						
Air pressure and functions	Air pressure	Check visually.	The operating air pressure should be 0.4 to 0.6 Mpa						
	Lubrication		Lubrication should be implemented by the lubricator (line oiler) at a rate of 10 to 15 drips (2 to 3 cc) per minute.						
	Operational check	Operate the cord or the pendant	The load chain can be wound smoothly. The air hoist should move in the same direction as cord or pendant (lever) operation. When the operation is stopped, the motor stops immediately. When the emergency stop button is pressed, all hoist motions stop. When operating other push button while the emergency stop button is pressed, the hoist does not start operation. When canceling the emergency stop button, the hoist operates normally.						
			When stopping the operation, the brake is applied immediately and bottom hook shall stop immediately.						
	Brake	Operate the cord or the pendant to run the air hoist at low speed.	Configuration of parts and routing of the chain should be appropriate for activating the device. The limit lock, swivel hook or chain should push back the chain lever at the lifting limit or the lowering limit to deactivate the device reliably.						
	Overwinding prevention device		Operate the cord or the pendant to check an operating sound.	No abnormal sound and vibrations					
Abnormal sound and vibrations									

Model	Code	Capacity	Serial No.	Your CTRL No.	Installation date	Location
Plain trolley						

Category	Check item	Check method	Criteria	Inspection date/result				
				/	/	/	/	/
Appearance	Nameplates, labels and tags	Check visually.	No peel off. Indication can be seen clearly.					
	Body and each part		No apparent deformation, damage, flaw and crack					
	Bolts, nuts, split pins and snap pins		Should be reliably attached without being loosened or missing.					
Functions	Operational check	operation	Should traverse smoothly without meandering and vibrations.					

■ Check Sheet for Frequent Inspection

Model	Code	Capacity	Serial No.	Your CTRL No.	Installation date	Location
Air hoist						

Category	Check item	Check method	Criteria	Inspection date/result				
				/	/	/	/	/
Load chain	Pitch	Measurement	The limit value of the following "Sum of pitches of five links" must not be exceeded.					
	Chain diameter	Measurement	The limit value of the following "Chain diameter of the load chain" must not be exceeded					
Hook	Opening and abrasion of the hook	Check visually. Measurement	Should not exceed the following service limit value. The opening dimension L should be less than "L + 2" mm, compared with the dimension of new item. The height H of the hanging part should exceed "H - 2" mm.					
	Deformation, flaw and corrosion	Check visually.	No deformation such as bend or twist No deep cut No loosened bolt or nut for hook latch, or their fall off No considerable corrosion No attachment of foreign matter such as sputter					
Peripheral parts of the body	Chain container	Check visually.	To be mounted to the body securely No damage, tear, abrasion or deformation Check no foreign matter inside the chain container. The lift of the air hoist should be shorter than the allowable storage length indicated on the chain container.					
	Chain end on the no-load side	Check visually.	The bolts (screws) used for securing the chain to the hoist body should be tight and not missing. The chain-down stopper locking bolts should be tight and not missing.					
	Chain fixing part peripheral parts on the no-load side Chain-down stopper Chain washer	Check visually.	No apparent deformation, damage and crack					
	Chain lever	Check visually.	No apparent deformation, damage and crack					
Cord or pendant	Operating portion /supporting portion	Check visually. No-load operation	Cord type: - The S-shaped wire should not be opened. - The hanging part of the S-shaped wire should not be deformed. - The cord caulked part should not be disengaged. - The cord (string) should not be damaged. Pendant type: - The pendant hose joint should be tight. - The pendant hose should not be damaged. - The pendant hose supporting wire or the chain fixing screw should be reliably attached without looseness so that no force will be applied to the hose even if the pendant is pulled.					
Air supply hose and joint	Appearance Attachment	Check visually.	The air supply hose should not be deformed or damaged. The hose band, etc. should be tight at the joint to the air hoist or the trolley.					
Functions	Abnormal sound	No-load operation Check in the vicinity of the hoist body.	To sound no irregular noise To sound no howling of motor and scraping sound of the brake There should be no chain cracking sound emitted from near the chain separator (chain inlet/outlet).					

Model	Code	Capacity	Serial No.	Your CTRL No.	Installation date	Location
Plain trolley						

Category	Check item	Check method	Criteria	Inspection date/result				
				/	/	/	/	/
Appearance	Nameplates, labels and tags	Check visually.	No peel off. Indication can be seen clearly.					
	Body and each part		No apparent deformation, damage, flaw and crack					
	Bolts, nuts, split pins and snap pins		Should be reliably attached without being loosened or missing.					
Functions	Operational check	operation	Should traverse smoothly without meandering and vibrations.					

Warranty

KITO Corporation ("KITO") extends the following warranty to the original purchaser ("Purchaser") of new products manufactured by KITO (KITO's Products).

- 1) KITO warrants that KITO's Products, when shipped, shall be free from defects in workmanship and/or materials under normal use and service and KITO shall, at the election of KITO, repair or replace free of charge any parts or items which are proven to have said defects, provided that all claims for defects under this warranty shall be made in writing immediately upon discovery and, if there is anything within **a warranty period stated by your dealer from whom you purchased the products** from the date of purchase of KITO's Products by Purchaser and provided, further, that defective parts or items shall be kept for examination by KITO or its authorized agents or returned to KITO's factory or authorized service center upon request by KITO.
- 2) KITO does not warrant components of products provided by other manufacturers. However to the extent possible, KITO will assign to Purchaser applicable warranties of such other manufacturers.
- 3) Except for the repair or replacement mentioned in (1) above which is KITO's sole liability and purchaser's exclusive remedy under this warranty, KITO shall not be responsible for any other claims arising out of the purchase and use of KITO's Products, regardless of whether Purchaser's claims are based on breach of contract, tort or other theories, including claims for any damages whether direct, incidental or consequential.
- 4) This warranty is conditional upon the installation, maintenance and use of KITO's Products pursuant to the product manuals prepared in accordance with content instructions by KITO. This warranty shall not apply to KITO's Products which have been subject to negligence, misuse, abuse, misapplication or any improper use or combination or improper fittings, alignment or maintenance.
- 5) KITO shall not be responsible for any loss or damage caused by transportation, prolonged or improper storage or normal wear and tear of KITO's Products for loss of operating time.
- 6) This warranty shall not apply to KITO's Products which have been fitted with or repaired with parts, components or items not supplied or approved by KITO or which have been modified or altered.

THIS WARRANTY IS IN LIEU OF ALL OTHER WARRANTIES. EXPRESS OR IMPLIED, INCLUDING BUT NOT LIMITED TO ANY WARRANTY OF MERCHANTABILITY OR OF FITNESS FOR A PARTICULAR PURPOSE.

This warranty is not applicable in Australia. Please refer to your local supplier for warranty details when this product is purchased in Australia.

KITO
Global Website: kito.com

Correction Note



OM-TCSZZZ-JP0-00
English

TCS Series Air Hoist (250 kg to 980 kg)

Instruction Manual

P17

■ Lubrication

⚠ CAUTION

 Mandatory

Be sure to apply a lubricant to the load chain.

To lubricate the motor, use a lubricator (line oiler) to apply 10 to 15 drips (~~2 to 3 cc~~) of lubricant per minute. **Correct : 0.2 to 0.3cc**

When storing the air hoist for a long period or when using it again after long-term storage, lubricate 2 to 3 cc from the air supply hose joint, perform low-speed operation to accustom, and then, store or use it again.

Use only the specified lubricants.

Improper lubrication may not only cause trouble and malfunctioning due to rust, early wear of internal parts, but lead to bodily injury due to these factors.

P44

■ Air pressure and functions

Check the following item with no load.

Item	Check method	Criteria	When failed
Air pressure	Check visually.	The operating air pressure should be 0.4 to 0.6 MPa (recommended pressure: 0.6 MPa).	Adjust to the appropriate pressure.
Lubrication	Check visually.	Lubrication should be implemented by the lubricator (line oiler) at a rate of 10 to 15 drips (2 to 3 cc) per minute.	With the lubricator, adjust a lubrication rate appropriately.

Correct : 0.2 to 0.3cc